

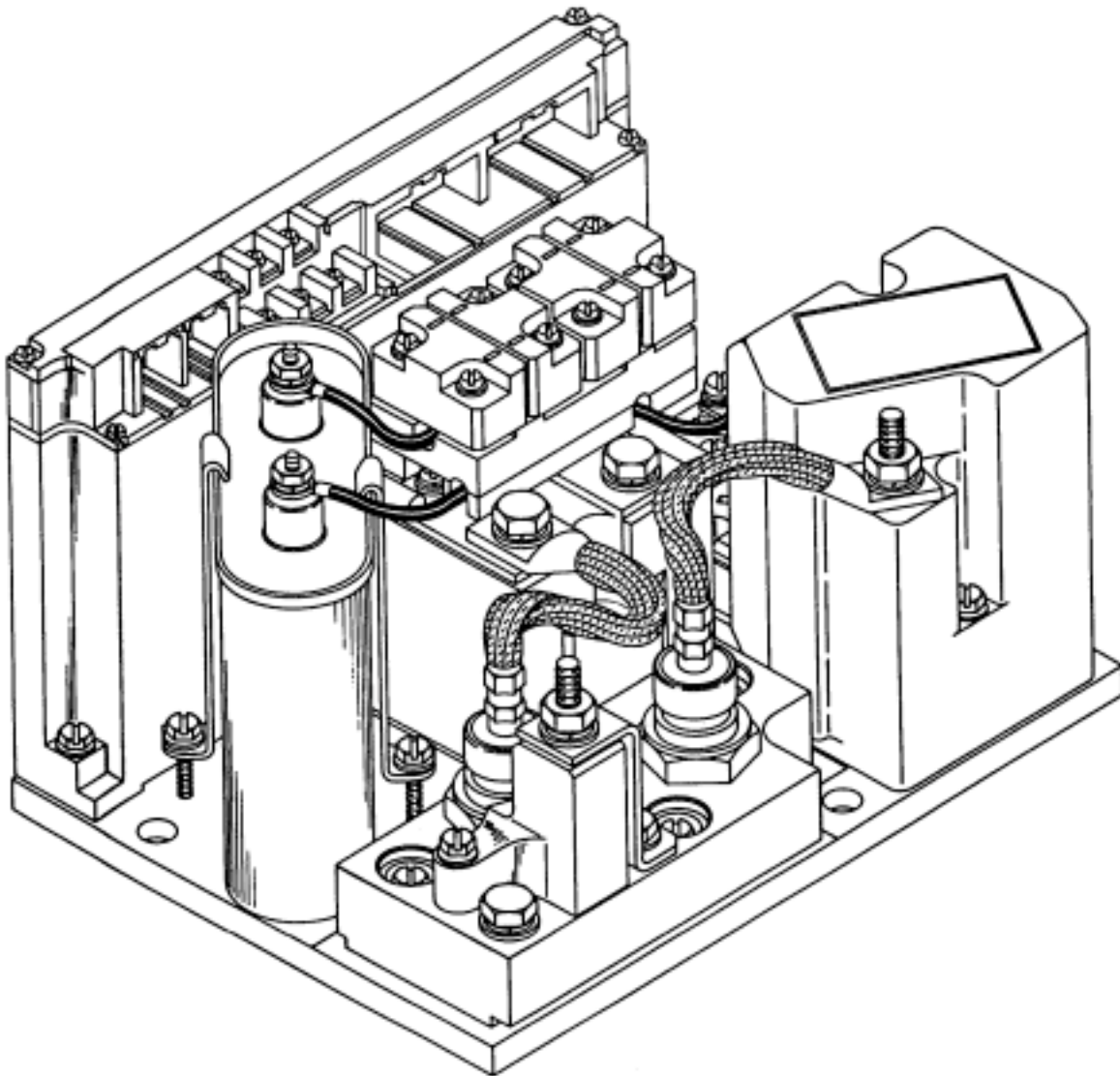

**GE Electric Vehicle  
Systems**

**INSTRUCTIONS  
EV100 ZX SCR  
CONTROLS**



The information contained herein is intended to assist truck users and dealers in the servicing of SCR controls furnished by the General Electric Company. It does not purport to cover all variations in equipment nor to provide for every possible contingency to be met with installation, operation or maintenance.

Should further information be desired or should particular problems arise which are not covered sufficiently for the purchaser's purpose, the matter should be referred to the truck manufacturer through his normal service channels, not directly to the General Electric Company.

# EV100ZX SCR CONTROL ORDERING INFORMATION

EXAMPLE-----	IC3645EV	100	T1	ZT	1
ARGUMENT NO.	01	02	03	04	05

**ARGUMENT NO. 01 - BASIC CATALOG NUMBER**

**ARGUMENT NO. 02 - POWER BASE RATING**

- 100 - EV100 POWER BASE ( APPLICATIONS LESS THAN 150 FLLR )
- 200 - EV200 POWER BASE ( APPLICATIONS LESS THAN 200 FLLR )

**ARGUMENT NO. 03 - APPLICATION AND 1 REC OPTIONS**

- T1 - STANDARD CURRENT LIMIT TRACTION
- T2 - HIGH PERFORMANCE CURRENT LIMIT TRACTION
- P1 - STANDARD CURRENT LIMIT PUMP
- P2 - HIGH PERFORMANCE CURRENT LIMIT PUMP

**ARGUMENT NO. 04 - LOGIC CARD OPTIONS**

- ZX - TRACTION WITHOUT BDI
- ZT - TRACTION WITH BDI
- ZP - PUMP CONTROL WITH TMM
- ZY - 3-WIRE POT TRACTION WITHOUT BDI
- ZH - 3-WIRE POT TRACTION WITH BDI

**ARGUMENT NO. 05 - REVISION CODE**

- 1 - ACTIVE

# EV100ZX COMPONENT LOCATIONS

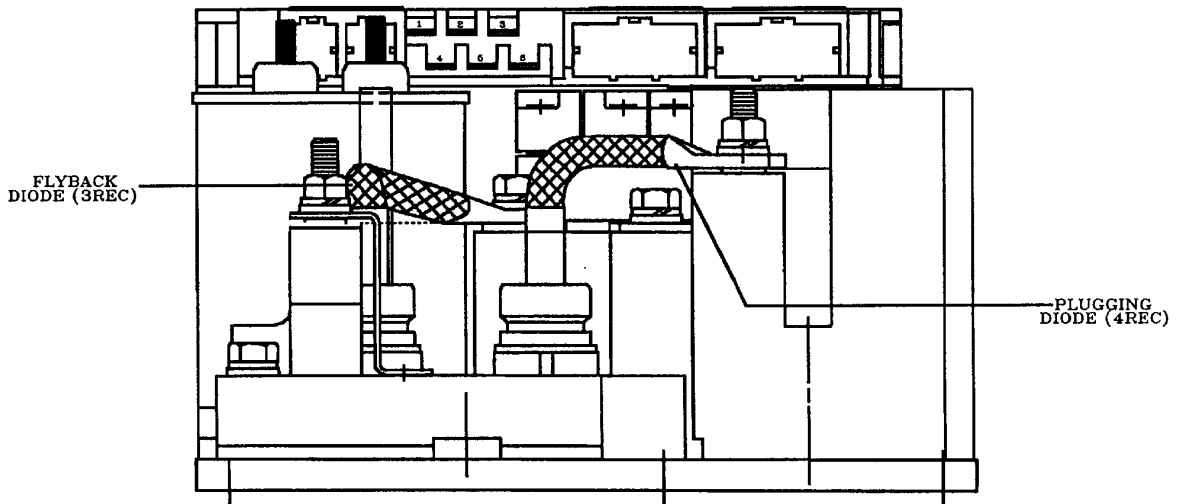
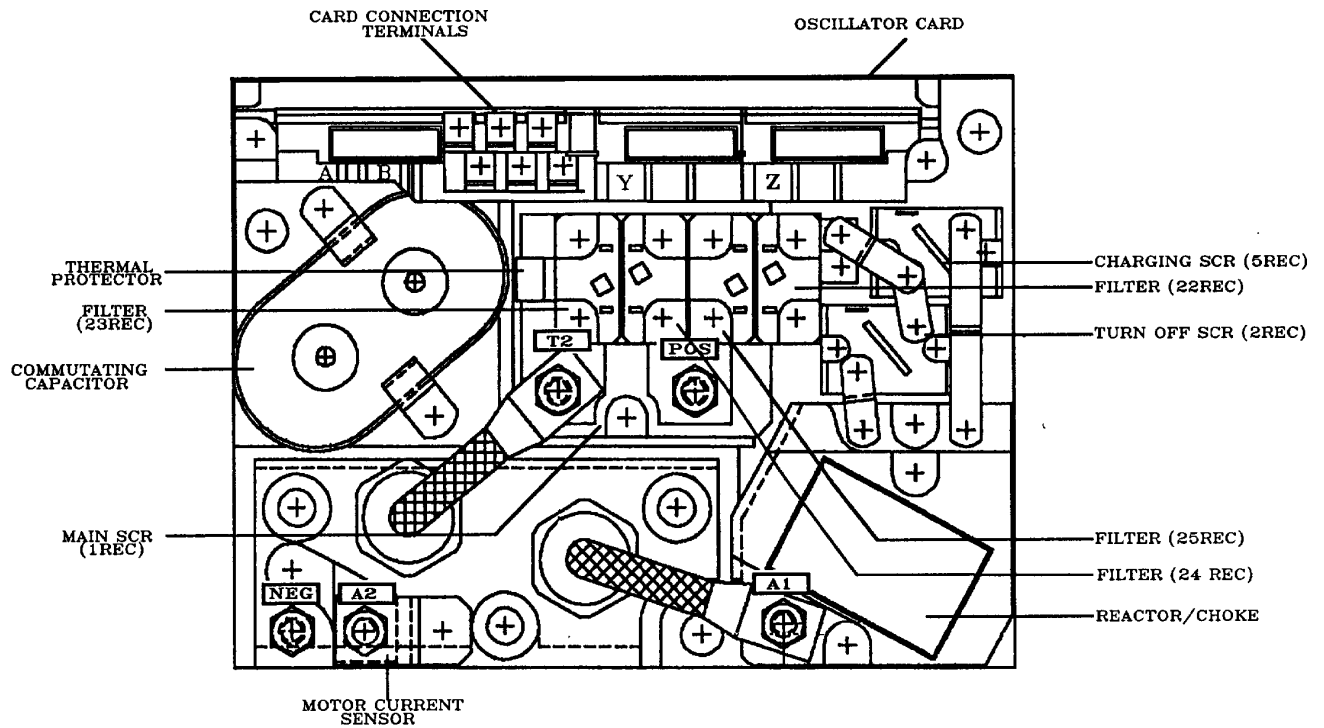

# EV100ZX OUTLINE DRAWING

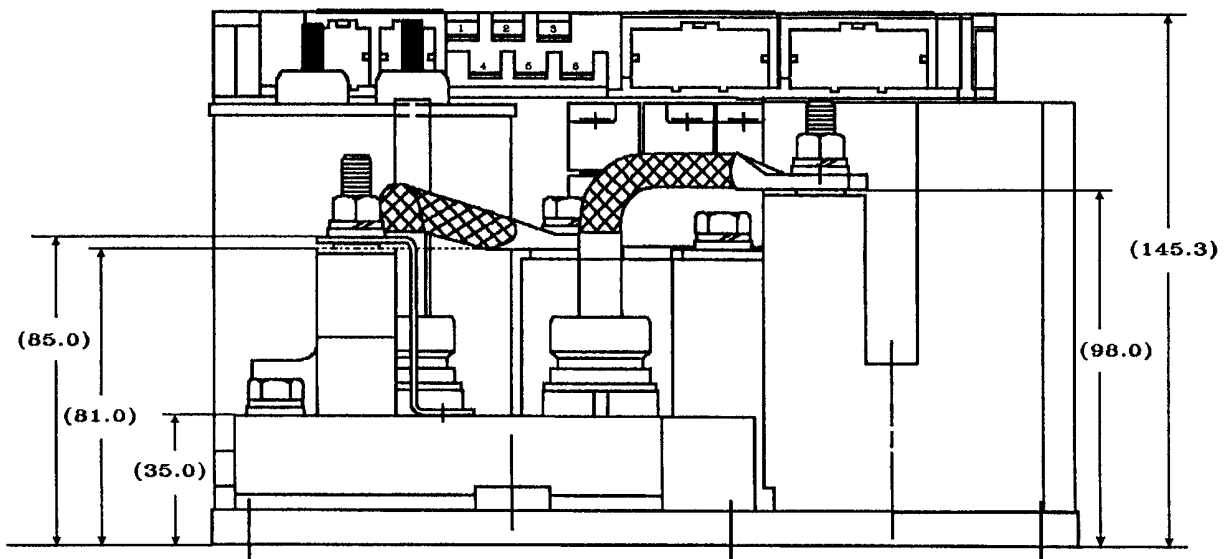
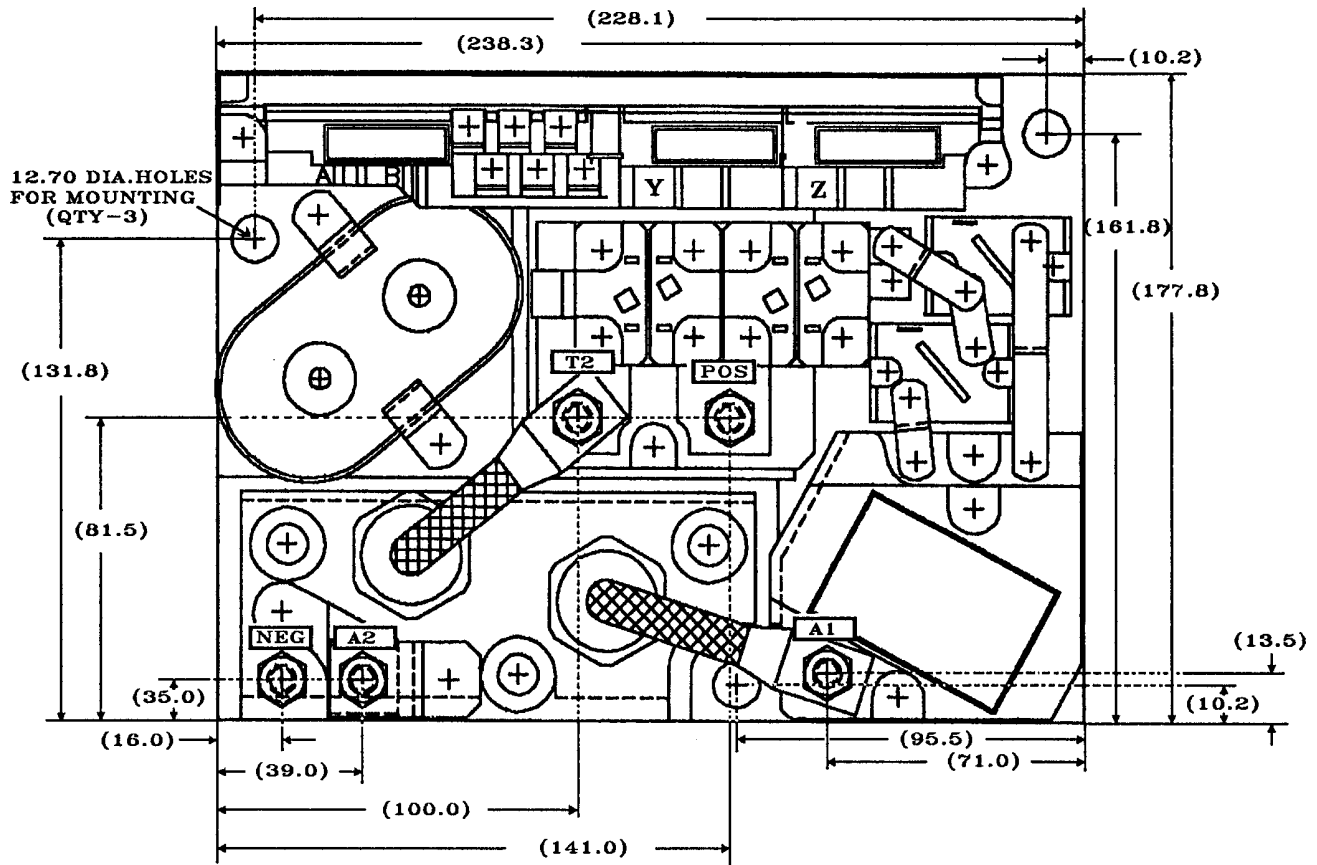

# EV100ZX WITH SPEED LIMIT AND FW

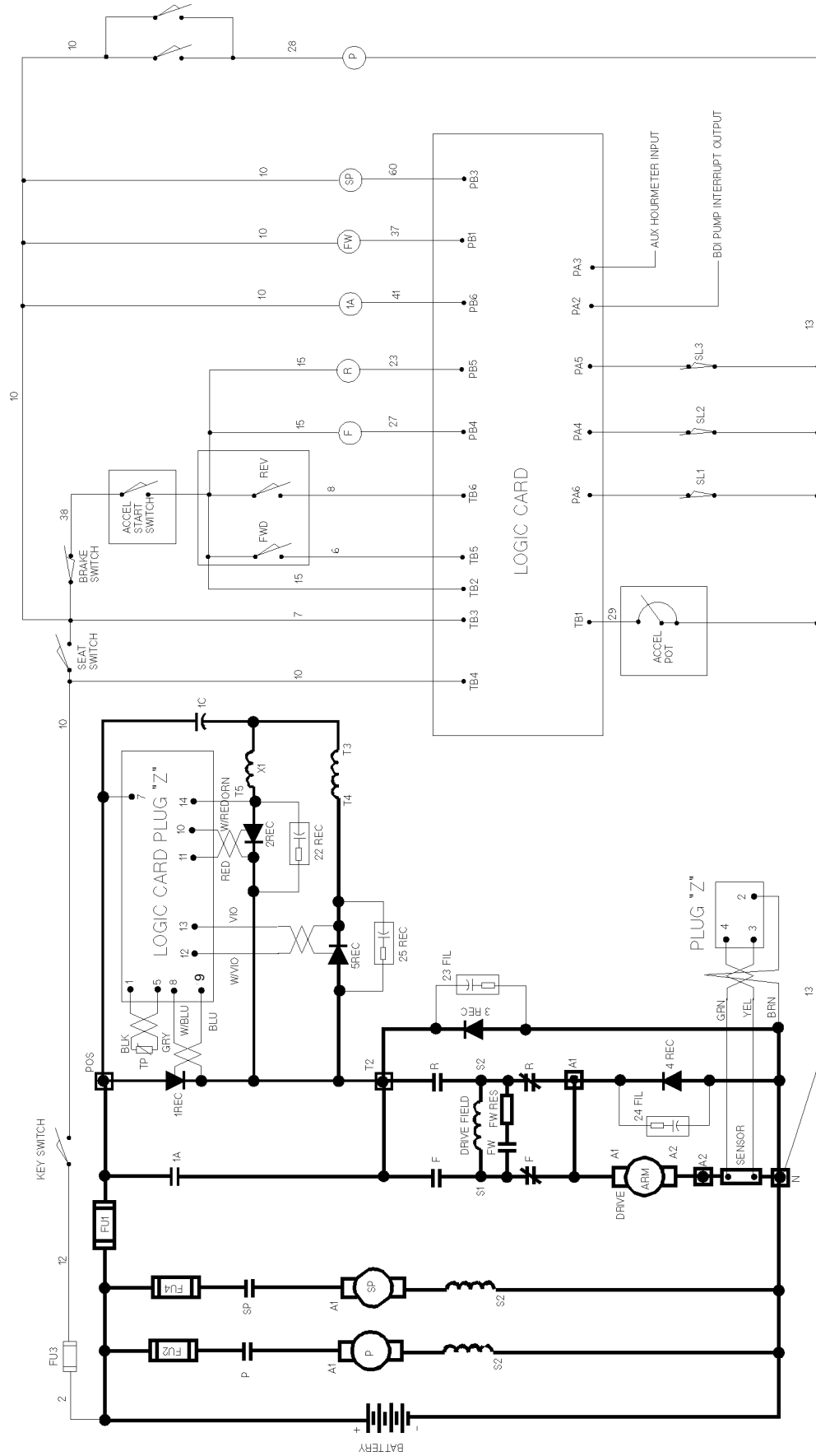

# EV100ZX WITH REGEN AND FW

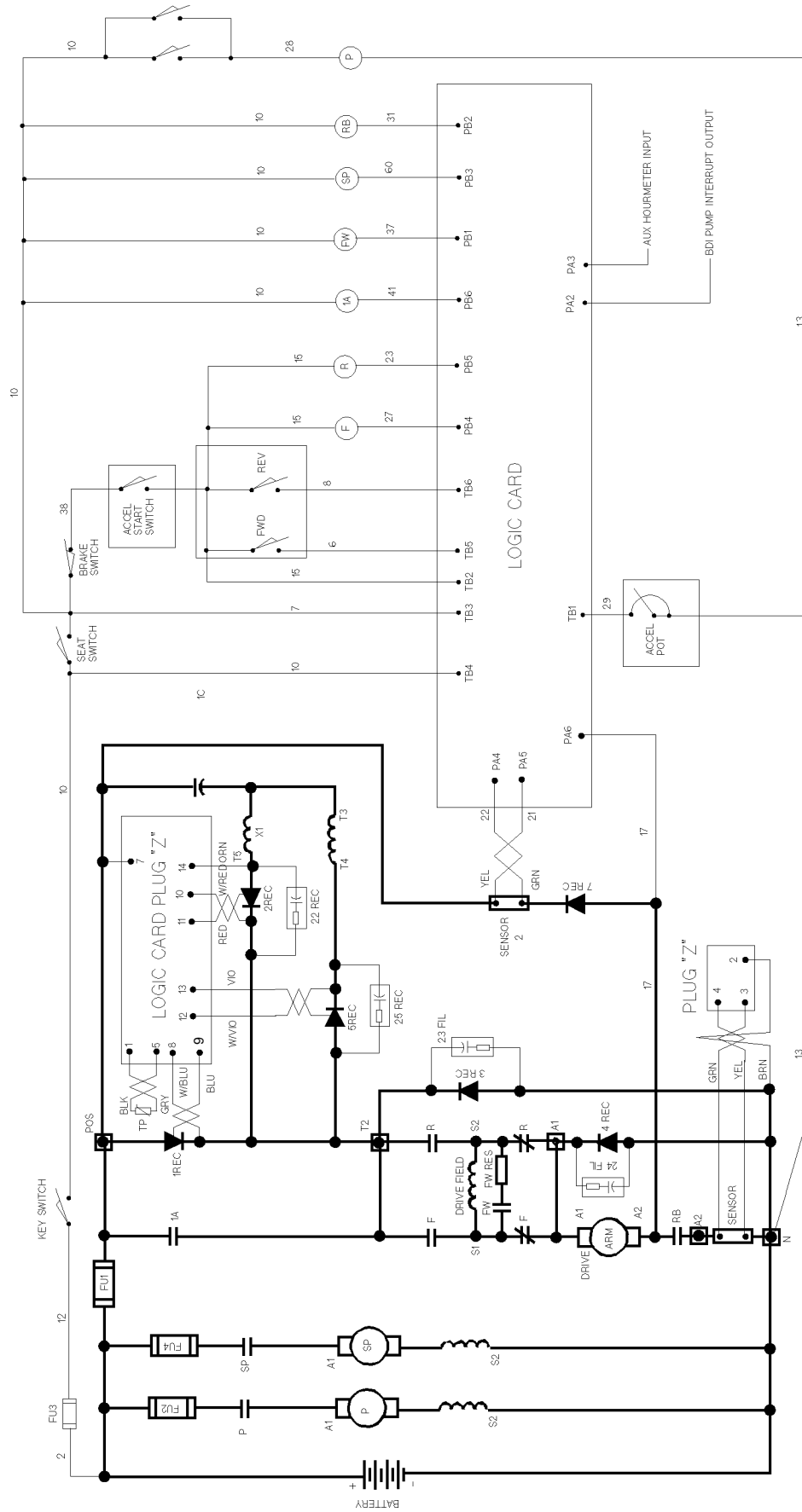

# EV100ZX PUMP CONTROL

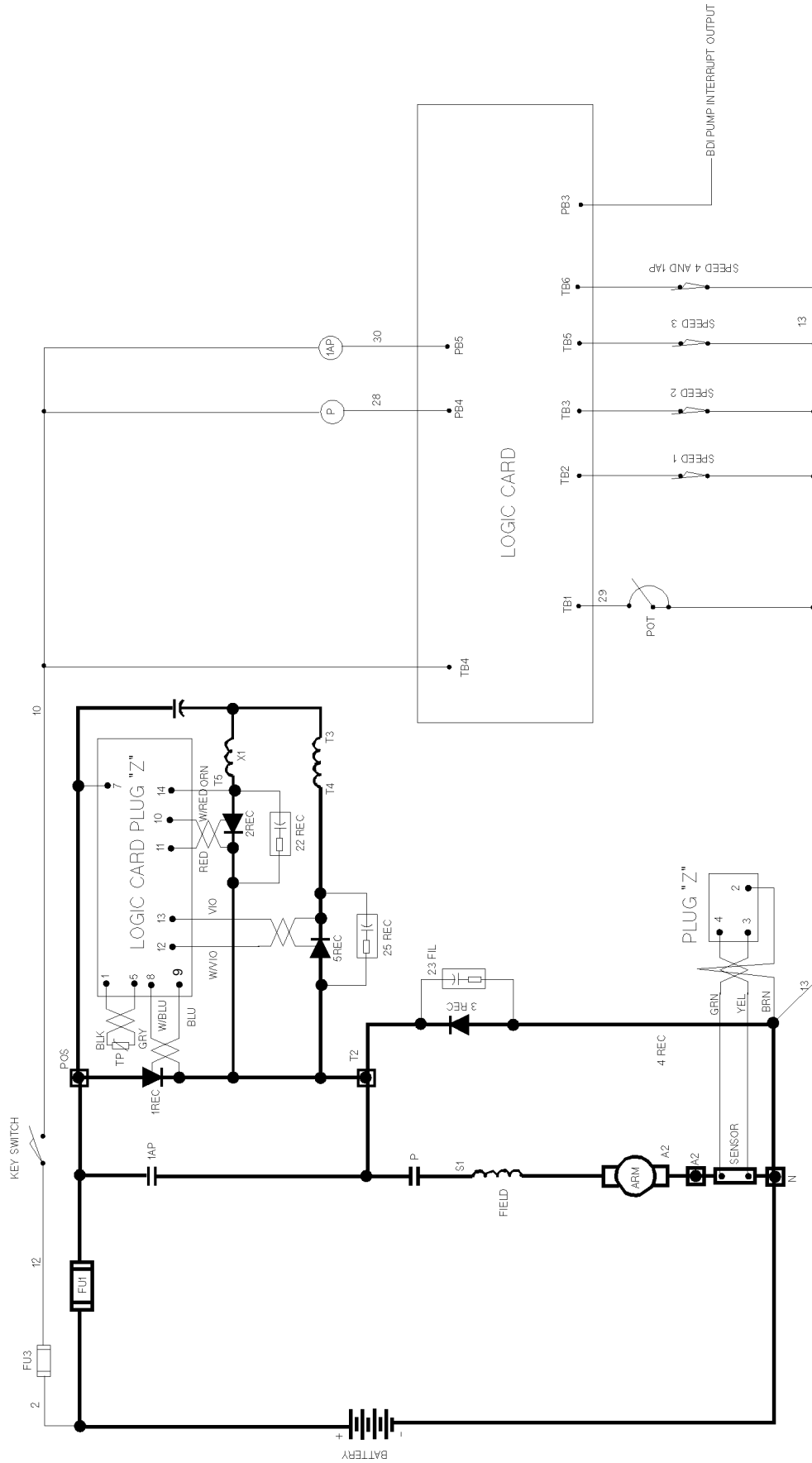

# EV100ZX PART NUMBER IDENTIFICATION

NO.	PART-NUMBER	DESCRIPTION	QUANTITY
4	158C3100EEP1	BASE DETAIL .....	01
11	171B3939G1	1REC ASSEMBLY LOW POWER .....	01
11	171B3939G2	1REC ASSEMBLY HIGH POWER .....	01
12	273A2523P9	THRM COND INSULATION .....	01
14	171B3949G1	3 AND 4 REC. ASM. ....	01
15	259A3290P1	INSULATING BUSHING .....	03
16	273A2523P8	THRM COND INSULATION .....	01
18	44A717068-001	SCR, 2REC .....	01
19	44A717067-001	SCR, 5REC .....	01
20	44A723544-001	CAP. "WARNING" LABEL .....	01
21	44A723543-001	EV-100 LOGO LABEL .....	01
22	158C3234G1	REACTOR ASSEMBLY .....	01
24	259A9053P2	CAP MT FILM 150MF 25 .....	01
26	IC3645LXCD1TX	TRACTION WITHOUT BDI .....	01
26	IC3645LXCD1TT	TRACTION WITH BDI .....	01
26	IC3645LXCD1MX	DUAL MTR TRACTION WITHOUT BDI .....	01
26	IC3645LXCD1MT	DUAL MTR TRACTION WITH BDI .....	01
26	IC3645LXCD1PX	PUMP CONTROL .....	01
28	171B3933G1	SPIDER AND WIRE ASM. ....	01
29	44A727009-G01	THERMISTOR ASM .....	01
30	171B3940G1	SNUBBER ASM. ....	04
34	44A718897-001	CAPACITOR MTG. STRAP .....	02
37	148B5620DPP1	BUS BAR .....	01
38	148B5620DPP2	BUS BAR .....	01
39	148B5620DPP4	BUS BAR .....	01
40	148B5620DPP3	BUS BAR .....	01
43	WH7138R36G1	WIRE HARNESS .....	01
48	L201P17B33	NUT, M8X1.25MM .....	02
49	L400P10B33	M8 FLAT WASHER .....	05
50	L401P27B33	M8 LOCK WASHER .....	05
52	44A723274-001	M5X50MM T/R SCREW .....	04
53	44A723274-002	M5X26MM T/R SCREW .....	07
54	L14P17020B33	M8X1.25X20MM SCREW .....	03
55	L10P14010B33	M5X0.8X10MM SCREW .....	05
56	L400P7B33	M5 NAR. FLAT WASHER .....	05
57	L401P25B33	M5 SPRING LOCKWASHER .....	05
58	44A723274-401	M3.5X12MM T/R SCREW .....	04
59	L10P11044B33	M3.5X0.6X44MM SCREW .....	01
60	44A723274-204	M3.5X23MM T/R SCREW .....	08
61	L400P5B33	M3.5 NAR FLAT WASHER .....	06
62	L401P23B33	M3.5 LOCK WASHER .....	06
63	L10P11008B33	M3.5X0.6X8MM SCREW .....	06
64	L10P11016B33	METRIC PAN HD SCREW .....	02
67	L14P15016B33	M6X1.0X16MM SCREW .....	01
69	L400P8B33	M6 FLAT WASHER .....	01
70	171B3954G1	SHUNT-WIRE ASM .....	01
73	N402P39B6	WASHER FLAT ST .....	03



# EV100ZX PART NUMBER IDENTIFICATION

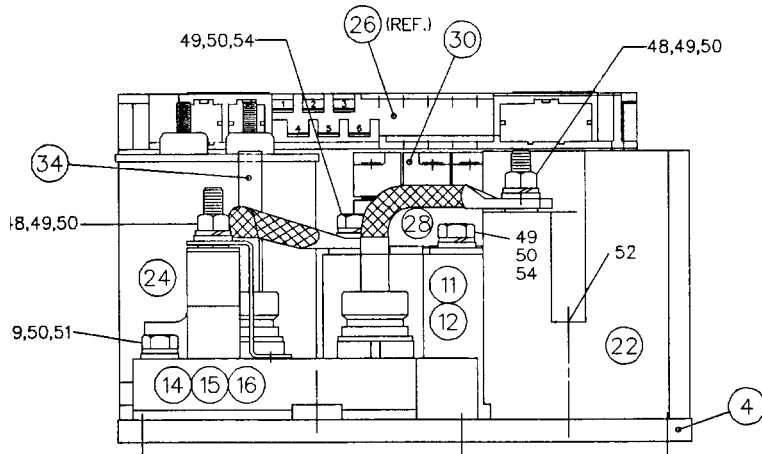
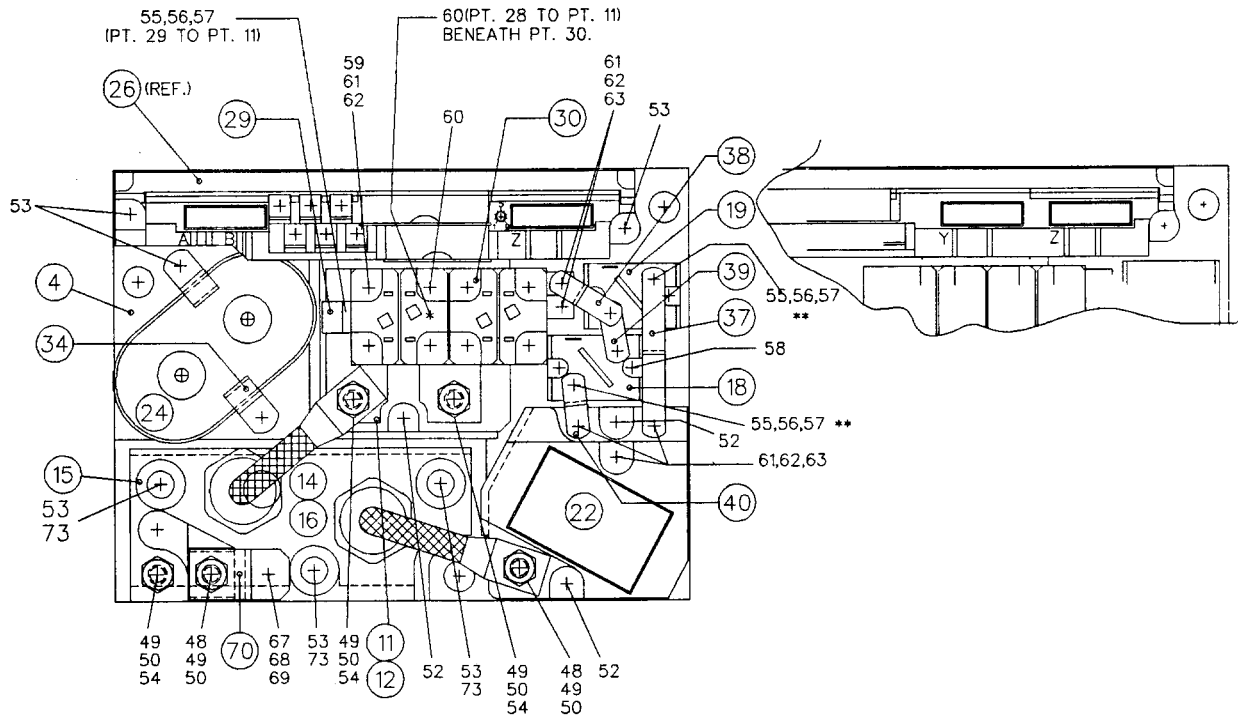

EV-100

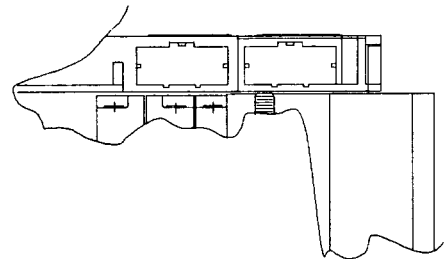

EV-100 LX/LXT

## RECOMMENDED TORQUEING

DEVICE OR PART TO PART	HARDWARE	HARDWARE TYPE	TORQUE LBS/IN
18, 19 TO 4	M3.5 X 0.6	FORMING	14
28 TO 11	M3.5 X 0.6	MACHINE	10
37, 40 TO 22	M3.5 X 0.6	MACHINE	10
38 TO 28	M3.5 X 0.6	MACHINE	8
11 (GATE TERM.)	M3.5 X 0.6	MACHINE	8
30 TO 11	M3.5 X 0.6	MACHINE	10
30 TO 28	M3.5 X 0.6	MACHINE	10
34 TO 4	M5 X 0.8	FORMING	14
14 TO 4	M5 X 0.8	FORMING	40
22 TO 4	M5 X 0.8	FORMING	40
11 TO 4	M5 X 0.8	FORMING	40
26 TO 4	M5 X 0.8	FORMING	14
29 TO 11	M5 X 0.8	MACHINE	14
37 TO 19	M5 X 0.8	MACHINE	14
38, 39 TO 19	M5 X 0.8	MACHINE	14
39 TO 18	M5 X 0.8	MACHINE	14
40 TO 18	M5 X 0.8	MACHINE	14
70 TO 14	M6 X 1.0	MACHINE	40
24 (TERMINALS)	#10-32	NUT	18

## RECOMMENDED TORQUEING

DEVICE OR PART TO PART	HARDWARE	HARDWARE TYPE	TORQUE LBS/IN
* 70 TO 14(T.POST)	M8 X 1.25	NUT	75
* 14 (4REC) TO 22	M8 X 1.25	NUT	75
* 14 (3REC) TO 11	M8 X 1.25	BOLT	75
* 11 (BATT. POS.)	M8 X 1.25	BOLT	75
* 14 (BATT. NEG.)	M8 X 1.25	BOLT	75

\* CUSTOMER REFERENCE ONLY.

ASM. NOTE: USE SILICONE GREASE (DOC#342 OR GE#641) UNDER 1REC BETWEEN THERMAL INSULATION (PT.12) AND ALUMINUM BASE (PT.4).

USE SILICON GREASE (DOC#342 OR GE#641) UNDER 2 REC AND 5 REC (PTS. 18 & 19).

\*\* VENDOR SUPPLIED HARDWARE IS ALLOWED FOR CONNECTIONS TO PT. 18 & 19)

## TERMINAL CONNECTIONS FOR ZX LOGIC CARDS

<b>INPUT</b>	<b>TRACTION STANDARD</b>	<b>TRACTION SL/FW</b>	<b>TRACTION REGEN/FW</b>	<b>PUMP</b>
TB1	Accel Pot Input	Accel Pot Input	Accel Pot Input	Accel Pot Input
TB2	Start Switch Input	Start Switch Input	Start Switch Input	SL1
TB3	Seat Switch Input	Seat Switch Input	Seat Switch Input	SL2
TB4	Key Switch Input	Key Switch Input	Key Switch Input	Key Switch Input
TB5	Forward Switch Input	Forward Switch Input	Forward Switch Input	SL3
TB6	Reverse Switch Input	Reverse Switch Input	Reverse Switch Input	SL4
PA1	Plug Signal	Plug Signal	Plug Signal	Status Code 93 Input
PA2	BDI Interrupt	BDI Interrupt	BDI Interrupt	Status Code 93 Input
PA3	Hourmeter Input	Hourmeter Input	Hourmeter Input	Status Code 90 Input
PA3 (Opt)	C/L Reduction Input (Opt)	C/L Reduction Input (Opt)	C/L Reduction Input (Opt)	
PA4	Not Used	SL2	Sensor 2 Yellow Wire	Status Code 94 Input
PA5	Not Used	SL3	Sensor 2 Green wire	Status Code 94 Input
PA6	Not Used	SL1	Mtr A2 Input	Status Code 91 Input
PB1	FW Coil Driver	FW Coil Driver	FW Coil Driver	Status Code 95 Input
PB2	Not Used	Not Used	Regen Coil Driver	Status Code 95 Input
PB3	SP Coil Driver	SP Coil Driver	SP Coil Driver	BDI Enable Signal Input
PB4	F Coil Driver	F Coil Driver	F Coil Driver	Pump (PMT) Coil Driver
PB5	R Coil Driver	R Coil Driver	R Coil Driver	1A Coil Driver
PB6	1A Coil Driver	1A Coil Driver	1A Coil Driver	Status Code 92 Input
PY1	Dash Display 4 Input	Dash Display 4 Input	Dash Display 4 Input	Dash Display 4 Input
PY2	Dash Display 3 Input	Dash Display 3 Input	Dash Display 3 Input	Dash Display 3 Input
PY3	Dash Display 1 Input	Dash Display 1 Input	Dash Display 1 Input	Dash Display 1 Input
PY4	Dash Display 2 Input	Dash Display 2 Input	Dash Display 2 Input	Dash Display 2 Input
PY5	Dash Display 5 Input	Dash Display 5 Input	Dash Display 5 Input	Not Used
PY6	Handset Store	Handset Store	Handset Store	Handset Store
PY7	Im	Im	Im	Not Used
PY8	TMMA-9 / Pump-PY12	TMMA-9 / Pump-PY12	TMMA-9 / Pump-PY12	Not Used
PY9	TMMA-7 / Pump-PY11	TMMA-7 / Pump-PY11	TMMA-7 / Pump-PY11	Not Used
PY10	TMMA-2 / Pump-PY10	TMMA-2 / Pump-PY10	TMMA-2 / Pump-PY10	Traction PY10
PY11	Not Used	Not Used	Not Used	Traction PY9
PY12	MPH Input	MPH Input	MPH Input	Traction PY8
PY13	Serial Receive	Serial Receive	Serial Receive	Serial Receive
PY14	Serial Transmit	Serial Transmit	Serial Transmit	Serial Transmit
PZ6	+5 VDC Output	+5 VDC Output	+5 VDC Output	

## EV100ZX LOGIC CARD SPECIFICATIONS

CONTROL FEATURES	TRACTION	PUMP
On-Board Diagnostics	Standard Displayed to Handset or Dash Display	Standard Displayed to Handset or Dash Display
Hourmeter	1 - Displayed to Dash 1-Secure (Handset Read)	1 - Displayed to Dash 1 - Secure (Handset Read)
Stored Status Codes	16 Codes with BDI and Hourmeter Reference	16 Codes with BDI and Hourmeter Reference
Card Type Selection	Standard Enable/Disable Features	Standard Enable/Disable Features
Creep Speed	Adjustable 2% to 15% On Time	Not Applicable
Current Limit	Adjustable See C/L Curves Standard/High Performance	Adjustable See C/L Curves Standard/High Performance
Plugging	Adjustable 200 to 930 Amps	Not Applicable
Pedal Position Plug	Adjustable 100 to 930 amps Can be Disabled	Not Applicable
Ramp Start	Standard	Not Applicable
Full Power Transition	Standard with 1A Ctr	Standard with 1A Ctr
Controlled Acceleration	Adjustable .1 to 22 seconds	Adjustable .1 to 5.5 seconds
1A Timed Pick-Up	Follows CA by .2 seconds with Accel Volts is < .5V or Accel Ohms is < 200	Follows CA by .2 seconds with Accel Volts is < .5V or Accel Ohms is < 200
1A Thermal Hold-Off	Standard at 90°C cutback at 20% T <sub>ON</sub>	Standard at 90°C cutback at 20% T <sub>ON</sub>
1A Plugging Hold-Off	Standard	Not Applicable
Delay to First Pulse	Standard	Standard
PMT (Fault Shut Down)	Standard Look Ahead and Reset Two Count	Standard Look Ahead and Reset Two Count
Thermal Protection	Standard 90°C Cutback	Standard 90°C Cutback
Static Return to Off	Standard 2 Second Delay	Not Applicable

<b>CONTROL FEATURES</b>	<b>TRACTION</b>	<b>PUMP</b>
Voltage Range	24-80 VDC	24-80 VDC
Accelerator Input	5000-0 Ohms 3.5-0 VDC	5000-0 Ohms 3.5-0 VDC
3-Wire Accelerator Pot Option	3.7 to 0.4 VDC	Not Available
Low Battery Operation	Standard 50% at 36-80 VDC 75% at 24 VDC	Standard 50% at 36-80 VDC 75% at 24 VDC
Reverse Battery Protection	Standard	Standard
Ambient Temperature	-30 to +50°C	-30 to +50°C
Approximate Weight	5.5 Kg	5.5 Kg
Coil Drivers		
F/R or Line	On-Board	On-Board
1A	On-Board	On-Board
FW	On-Board	Not Applicable
Regen	Not Applicable	Not Applicable
PS	On-Board	Not Applicable
Shorted Driver Protection	Standard	Standard
Shorted 3 REC Protection	Standard	Standard
F/R and Speed Input Switch Loading	Logic Current	Logic Current
1A Switch	Not Required	Not Required
1A Current Dropout	Adjustable 450 to 1260 Amps	Not Applicable
Regenerative Braking	Adjustable Regen C/L - 75A to 630A Regen Start - 15% to 96%	Not Applicable
Field Weakening	Adjustable Pick-up - 52A - 466A Drop-out - 65A to 895A	Not Applicable
Speed Limit Three Ranges Creep to Full Speed	Standard Adjustable Input by Limit Switch	Standard Adjustable Input by Limit Switch
Steer Pump Time Delay	Seat - .5 to 63 sec Neutral - .5 to 63 sec	Not Applicable

<b>CONTROL FEATURES</b>	<b>TRACTION</b>	<b>PUMP</b>
Accelerator Volts Lockout Accel volts > 2.5V	Standard	Standard
Battery Volts Check	Standard	Standard
C/L Reduction Input	Standard	Standard
Four Function Mode Registers Selectable by Interactive Dash Display	4 - C/A Modes 4 - FW Pickup Modes 4 - SL1 Modes	4 - C/A Modes 4 - SL2 Modes 4 - SL4 Modes
RS-232 Communication Port	Standard	Standard
Battery Discharge Indica- tion	Optional	Optional
Full Load Level Running Mtr Current at 50% 1A Duty	150 Amps Plus	150 Amps Plus
Continuous Duty Mtr Current with 0.3°C/Watt Heatsink at 40°C Ambient	103 Amps Plus	103 Amps Plus
Plug Current Limit Min-Max @ 1 Sec Min-Max @ 3 Sec	330/950 Amps 330/650 Amps	Not Applicable
Average Motor C/L with Typical Mtr Inductance		
Min-Max @ 30% T <sub>ON</sub>	405/640 Amps (STD)	405/640 Amps (STD)
Min-Max @ 50% T <sub>ON</sub>	320/565 Amps (STD)	320/565 Amps (STD)
Min-Max @ 70% T <sub>ON</sub>	230/495 Amps (STD)	230/495 Amps (STD)
Min-Max @ 30% T <sub>ON</sub>	475/690 Amps (H/P)	475/690 Amps (H/P)
Min-Max @ 50% T <sub>ON</sub>	455/685 Amps (H/P)	455/685 Amps (H/P)
Min-Max @ 70% T <sub>ON</sub>	435/680 Amps (H/P)	435/680 Amps (H/P)

# EV100ZX CURRENT LIMIT CURVES

## EV100ZX Traction and Pump H/P Curve

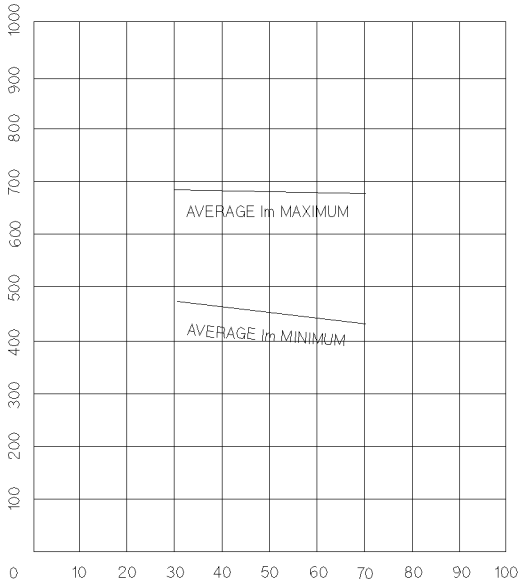

## EV100ZX Traction and Pump STD Curve

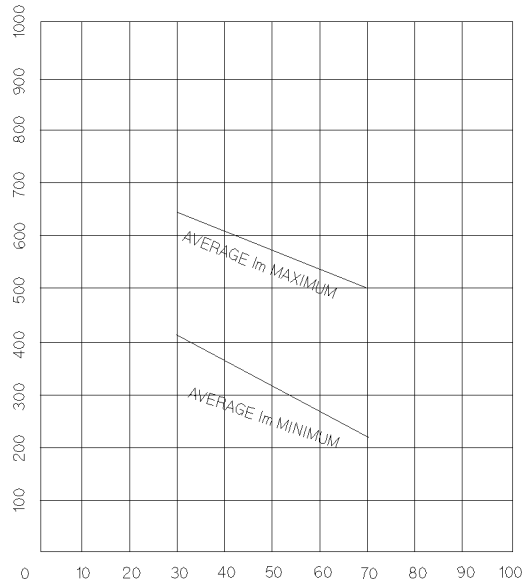

## BASICS OF CIRCUIT OPERATION

The control circuit is energized by closing the key switch, seat switch, and moving the forward or reverse lever to either position, and then depressing the accelerator closing the start switch. This applies power to the control card turning on the PMT driver, which will close the selected directional contactor and complete the circuits to the drive motor. (See elementary drawings.)

The control card then supplies a gate pulse to 2REC turning it on to a conducting state, allowing current to flow from the battery through IC, 1X, 2REC, motor field, motor armature, sensor, and back to the battery. After IC charges, 2REC shuts off due to lack of holding current. The control card checks that IC is charged and unlocks the gate to IREC and 5REC.

The control card then supplies a gate pulse to IREC turning it on to a conducting state, allowing current to flow from the battery through IREC, motor field, motor armature, sensor, and back to the battery. 5REC turns on and allows current to flow T4-T3, IC, IREC, 5REC to T4-T3. This current charges the bottom of IC positive with respect to the battery positive bus. This charging cycle occurs in less than 1 millisecond (.001 sec.) and 5REC shuts off. This charge is now stored on the capacitor until it is time to turn off IREC.

Current continues to flow in IREC until the control card fires 2REC. When 2REC conducts, capacitor IC discharges around the circuit composed of IC, 1X, 2REC, and IREC. This discharge current opposes the battery current through IREC so that the resultant current is zero. With reverse voltage across IREC, IREC is turned off. Current continues to flow in the 2REC, IC, motor and battery loop until the capacitor (card terminal I4) is fully charged negative. This charge exceeds battery voltage by an amount which is a function of peak motor current, and 2REC turns off. Figure 1 illustrates the pulsing of current from the battery.

Figure 1

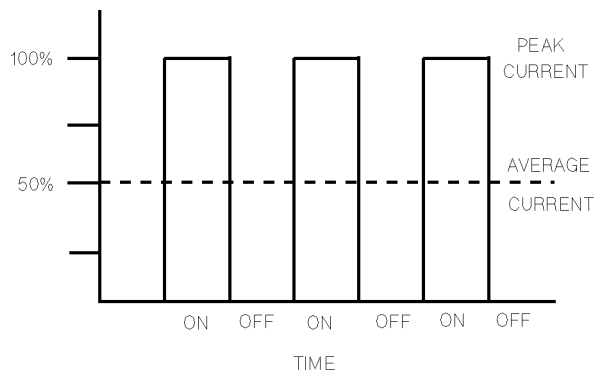

Battery current

Figure 2

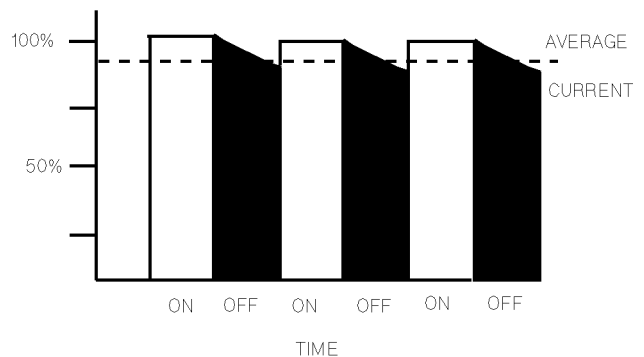

Motor current

During the off time, the energy stored in the motor, by virtue of the motors inductance, will cause current to circulate through the motor around the loop formed by 3REC. Thus, providing what

is called “flyback current”. Figure 2 shows the nature of the motor current which is composed of both battery current and the inductive flyback current. It should be noted that the average motor current measured will be greater than the average battery current. The SCR control, in effect, converts battery current at battery volts into a higher motor current and a lower motor volts.

The time for the next ON and OFF cycle to start is determined by the time that the control card takes to oscillate. This frequency of oscillation is controlled by the potentiometer in the accelerator and automatic circuitry in the card. Slow speed is obtained by having maximum ohms in the potentiometer. As the resistance in the potentiometer decreases, the speed of the motor increases. The SCR circuit is capable of delivering approximately 95% speed. For full speed operation, the IA contactor is closed to apply full battery voltage across the motor.

**CONTROL FEATURES**

**OSCILLATOR** - the oscillator section of the card has two adjustable features and one fixed feature.

With the accelerator potentiometer at maximum ohms, the creep speed can be adjusted by the

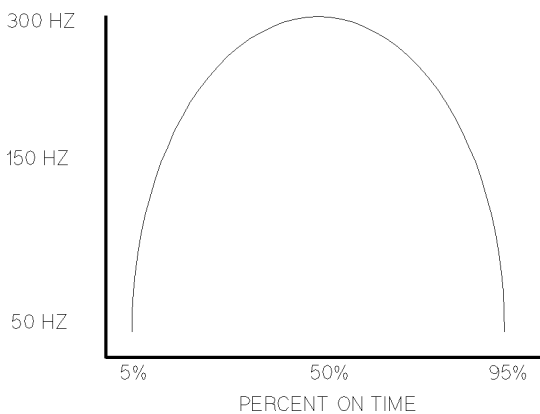

Figure 3

handset unit. Top speed is fixed by card and is obtained with the accelerator potentiometer at minimum ohms. The % ON time has a range of approximately 5 to 95 percent. The center operating condition of the oscillator is at 50 percent ON time with a nominal 1.8 milliseconds ON time and 1.8 millisecond OFF time. This corresponds to a maximum operating frequency of about 300 hertz. At creep the ON time will decrease to approximately 0.8 milliseconds while OFF time will become in the order of 20 milliseconds. At full SCR operation, this condition will be reversed (short OFF time, long ON time). This variation of ON and OFF time of the oscillator produces the optimum frequencies through the SCR range. The frequency curve of the oscillator is shown in Figure 3.

The rate at which the oscillator may increase its percent ON time is limited by “Controlled Acceleration”. The minimum time required to go from creep speed to 80-85% on time point may be varied by the “C/A” trimpot on the card, adjustable from approximately 0.1 seconds to 22.0 seconds.

**CURRENT LIMIT** - This circuit monitors motor current by utilizing a sensor in series with the armature. The information detected across the sensor is fed back to the card so current may be limited to a pre-set value. If heavy load currents are detected, this circuit overrides the oscillator and limits the average current to a value set by function 4 of the handset. The C/L setting is based on the maximum thermal rating of IREC and the peak voltage on the capacitor. Because of the flyback current through 3REC, the motor current usually runs 2 to 3 times battery current. See current limit curves for available current and adjustment range.



**PLUGGING** - Slow down is accomplished when reversing by providing a small amount of retarding torque for deceleration. If the vehicle is moving and the directional lever is moved from one direction to the other, the motor field is reversed. The plug signal is initiated by the fact that the directional switch has moved from one direction to the other. The motor armature, driven by the inertia of the vehicle, acts as generator. This generated current passes through 4REC and the sensor. The oscillator circuit regulates at a plug current limit level as set by the Handset this controls the pulse rate of IREC to regulate the generated motor current and bring the truck to a smooth stop and reversal. With the accelerator potentiometer at minimum resistance, function 5 will enable adjustment of plugging current from max to min. current level for plug current limit.

**PEDAL POSITION PLUG** - This feature will allow for plugging distance based on pedal position. Pedal position will reduce the plugging current to the current value set by this function as the accelerator is returned to the creep speed position. Maximum plug current is obtained with the accelerator in the top speed position. This feature is adjustable by using function 16 on the handset.

**RAMP START** - This feature provides full SCR torque to restart a vehicle on an incline. The memory for this function is the directional switch. When stopping on an incline, the directional switch must be left in its original or neutral position to allow the control to assure full power when restarted. The accelerator potentiometer input will modulate ramp start current.

**FULL POWER TRANSITION** - this built-in feature provides smooth transition from SCR to IA bypass. This is accomplished by the SCR continuing to pulse until the IA contactor power tips close.

**CONTROL ACCELERATION AND 1A TIME** - This feature allows for adjustment of the rate of time it takes for the control to accelerate to 96% applied battery voltage to the motor on hard acceleration. The 1A contactor will automatically close .2 seconds after the controlled acceleration stops and the accelerator input is less than .5 volts or less than 50 ohms. C/A is adjusted by function 3 from .1 to 22 seconds.

**1A CURRENT DROP OUT** - This adjustable feature can be set to open the 1A contactor if the traction motor is subject to excessive currents. The dropout is adjustable with function 6 of the handset. Once the control has dropped out the 1A contactor due to excess current, the directional or accelerator switch must be returned to neutral to unlock the dropout circuit to allow the control to pick up the 1A contactor again. Using this feature will reduce the 1A contactor tip life, thus it should be used only where needed to protect the motor.

**STATIC RETURN TO OFF** - This built-in feature of the control is set up to make the driver return the directional lever to neutral anytime he leaves the vehicle and returns. If the seat switch or key switch is opened, the control will shut off and cannot be restarted until directional lever is returned to neutral. A time delay of approximately .75 seconds is built into the seat switch input to allow momentary opening of the seat switch if a bump is encountered.

**ACCELERATOR VOLTS HOLD-OFF** This feature checks the voltage level at the accelerator input when ever the key switch or seat switch is activated. If the voltage is less than 2.5 volts the control will not start. This is to assure that the control is calling for low speed operation at start-up.

**COIL DRIVER MODULES** - these drivers are internal to the control card. They are the power devices

that operate F, R, IA, D, FW, RB, and PS contactor coils. These drivers open or close these coils on command from the control card. All modules are equipped with reverse battery protection in that if the battery is connected incorrectly, none of the contactors controlled can be closed electrically.

**IA THERMAL HOLD OFF** - this feature prevents the IA contactor from closing when the truck is in severe thermal cutback to avoid torque jumps. When the control goes into severe cutback, the must pulse to time will inhibit the IA timer.

**MUST PULSE TO TIME** - this feature prevents the IA timer from timing if the oscillation pulse rate has not reached a particular level of operation.

**PULSE MONITOR TRIP ( PMT )** - This feature contains three features which shuts down or locks out control operation if fault conditions exist that would allow uncontrolled ( run away ) speed of the vehicle:

- Look ahead
- Look again
- Automatic look again and reset

The PMT circuit will not allow the control to start under the following conditions:

1. If 1REC is shorted or if 1A contactor is welded, the control will not allow the F or R contactor to close.
2. Will not allow the control to operate if F and R internal coil drivers are shorted or if 3REC diode is shorted.

The PMT circuit will shut down operation of the control ( opening of the F or R contactor ) under the following conditions:

If 1REC fails to commutate ( shut off ), or if 1A power tips remain closed when they should be open. After opening the F or R contactor the PMT circuit will check for a fault and if none is found will reclose the directional contactor. If the fault still exist, the directional contactor will open and remain open.

If 1A closes before a second commutation failure, the look again counter will automatically reset. This eliminates the inconvenience of resetting the PMT with the key switch if the trip is due to random noise.

When the PMT circuit prevents F or R contactors from closing, the PMT circuit can be reset only by opening the key switch.

**THERMAL PROTECTOR** - (TP) - this temperature sensitive device is mounted on the IREC heat sink. If the IREC temperature begins to exceed the design limits, the thermal protector will lower the maximum current limit and not allow IREC to exceed its temperature limits. Even at a reduced current limit, the vehicle will normally be able to reach sufficient speed for full IA operation, thereby allowing the panel to cool. As the panel cools, the thermal protector will automatically return the control to full power.

**LOW VOLTAGE**- batteries under load, particularly if undersized or more than 80 percent discharged, will produce low voltages at the SCR control terminals. The EV-100 control is designed for use down to 50 percent of a nominal battery volts of 36-84 V, and 75 percent of a nominal battery volts of 24 V. Lower battery volts may cause the control to not operate correctly; however the PMT should open the F or R contactor in the event of a commutation failure.

**FIELD WEAKENING** - if the vehicle is supplied with a field weakening circuit, the "FW PU" and "FW DO" (function 7 and 8) can be adjusted from the handset unit. Field weakening is a method of attaining higher running speed for the vehicle in level operation. The normal settings for this feature are: pickup of FW contactor from 125 to 150 percent of normal full-load running current (IA), and dropout of FW contactor from 275 to 300 percent current. The dropout puts the motor back to the IA range to climb ramps and inclines.

**REGENERATIVE BRAKING** if the vehicle is moving and the directional lever is moved from one direction to the other, this initiates a plugging signal by reversing the motor field. During the standard motoring mode and the plugging mode, the RB contactor remains picked up. In the plugging mode, the motor armature acts as generator. Once the generated current reaches a particular current level, the plugging mode transitions to regenerative braking mode.

Transitioning to regenerative braking mode, opens the RB contactor, disconnecting the motor armature from battery negative and inserting 7REC and REGEN SENSOR-2 in the regen circuit. During the IREC on time, the field and armature current is increased. During the 1REC off time, the energy stored in the field and armature generates the regenerative current, which passes through 7REC, #2 sensor, battery, 3REC/4REC and back to motor field and armature.

The control will remain in regenerative mode as long as the regen current can maintain regenerative current limit. When the regenerative current cannot be maintained and drops below the level set by the regenerative current limit trimpot (RB C/L), the regenerative braking mode transitions back to plugging mode. During the transition back to plugging mode, the RB contactor will reclose enabling the control to function in plugging mode, regulating plugging currents to bring the vehicle to a smooth stop and reversal. The accelerator potentiometer input will modulate plugging as well as regenerative braking current. The major advantage of regen is longer motor life due to reduced motor heating. This feature has two adjustable functions, regen current limit (function 9) and regen start (function 10).

**TOP SPEED ( MOTOR VOLTS ) LIMIT** - This feature provides a means to limit motor volts to three adjustable limits by limit switch opening between input points on the control card and negative. The lower motor volt limit always takes priority when more than one switch input is closed. This motor volt limit effects top speed of the SCR, but actual truck speed will vary at any set point depending on the loading of the vehicle. Each speed limit is adjustable by the handset, function 11, 12, and 13, for speed limits 1, 2, and 3. **SL1 is active in all card types and must be disabled with the Handset.**

**STEER PUMP CONTACTOR TIME DELAY** - This feature provides two options for SP time delay option 1 provides a .5 to 63 second time delayed drop out of the steer pump contactor when the Forward or Reverse directional switch is opened. This is overridden by a 1.5 second time delayed drop-out whenever the seat switch is opened. Option 2 provides a .5 to 63 second time delayed drop out of the SP contactor when the seat switch is opened.

**CONSTANT CURRENT COIL DRIVERS AND INTERNAL COIL SUPPRESSION** - This feature allows the use of 24 volt contactor coils on through the entire voltage range of the EV100 ( 24 volts to 84 volts ) for the F,R,1A,SP,RG,D,and FW contactors.

This feature also allows the above contactors to operate cooler due to less current being applied to the coil after pick-up.

**HOURLY METER READINGS** - This feature will display the recorded hours of use of the traction control and pump control to the dash display each time the key switch is turned off.

**INTERNAL RESISTANCE COMPENSATION** - This feature is used when the Battery Discharge Indicator is present. Adjustment of this function will improve the accuracy of the BDI.

**TRUCK MANAGEMENT MODULE (TMM1)** - is a multi-function accessory card that provides the OEM the ability to provide status codes or operator warning codes that will be displayed on the dash display whenever a normally open switch or sensor wire provides a negative signal to the card. Typically the TMM1A can be used to display over temperature of motors, hydraulic systems or any other switch that closes at the desired temperature. The TMM1A can also be used to monitor and display motor brush wear warnings when the motor brushes require replacement.

**TRUCK MANAGEMENT MODULE (TMM2)** - is a multi-function accessory card that provides a horn alarm circuit which blows the horn when the truck is left unattended without the park brake being set, and also provides a dash board located controlled acceleration adjustment for use by the operator.

**STORED STATUS CODE** - This feature records 16 faults that have shut down vehicle operation (PMT faults that are reset by cycling the key switch). These status codes, along with the corresponding BDI and hourmeter readings, can be accessed with the Handset, or by using the RS-232 communications port and dumping the information to a Personal Computer terminal.

**RS-232 COMMUNICATION PORT** - This serial communication port can be used with interactive Dash Display to change vehicle operating parameters by the operator, or it can be used by service personnel to dump control operating information and settings into a Personal Computer.

**MAINTENANCE ALERT AND SPEED LIMIT** - This feature is used to display status code 99 and/or activate a speed limit when the vehicle operating hours match the hour set into the maintenance alert register. This warns the operator that required maintenance on the vehicle is due.

**CURRENT LIMIT REDUCTION** - This feature allows for the reduction of the current limit setting by 200 amps when a signal of 6 VDC or greater is applied to terminal PA3. This feature will reduce the possibility of communication failures during pump control operation.

**ON-BOARD DIAGNOSTICS** - The logic card detects the systems current operating status which can be displayed to either the Dash Display or the Handset. There are currently over 75 status codes that are available with systems using Traction and Pump SCR controls and Truck Management Module (TMM). Along with the status code display from the TMM, the logic card is capable of reducing the current to the control to alert the operator of a critical fault condition.

**BATTERY DISCHARGE INDICATION** - This feature uses the latest in microprocessor technology to

provide accurate battery state of charge information and supplies passive and active warning signals to the vehicle operator.

Features and functions:

- Displays 100 to 0 percent charge
- Display blinks with 20% charge
- Disables pump circuit with 10% charge
- Auto ranging for 36/48 volt operation
- Adjustable for use on 24 to 80 volts

**HANDESET** - This is a multi-functional tool to be used with the EV100 LX, LXT and ZX SCR controls. The Handset consist of a Light Emitting Diode (LED) display and a keyboard for data entry.

Features and functions:

- Monitor existing system status code for both traction and pump SCR systems
- Monitor intermittent random status code
- Monitor battery state of charge on LXT and ZX systems
- Monitor hourmeter reading on traction and pump SCR systems
- Monitor or adjust the control functions.

**DASH DISPLAY INTERACTION MODES** - There are four operator interaction modes that can be switched by the dash display. There are four Controlled Acceleration levels, four Field Weakening Pick Up levels and Four Speed Limit levels that can be pre-set and then selected by the operator from the dash display. These levels are pre-set using the Handset (Functions 48 - 62) or a Personal Computer (Functions 97 - 112). This feature allows the operator to select the best vehicle performance for changing factory conditions. The table below outlines the normal logic followed for pre-setting these four modes:

**Setting Logic Table**

	<b>Mode 1</b>	<b>Mode 2</b>	<b>Mode 3</b>	<b>Mode 4</b>
<b>C/A Time</b>	=> Mode 2	=< Mode 1 => Mode 3	=< Mode 2 => Mode 4	=< Mode 3
<b>FW Pickup</b>	=< Mode 2	=> Mode 1 =< Mode 3	=> Mode 2 =< Mode 4	=> Mode 3
<b>SL1</b>	=> Mode 2	=< Mode 1 => Mode 3	=< Mode 2 => Mode 4	=< Mode 3

**HYDRAULIC SCR CONTROL ( EV100P )** - This hydraulic controller consist of the following features:

- Three speeds adjustable from "0" volts to full motor volts.
- Fixed speeds actuated by switch closure to negative.
- 1A bypass contactor ( if required )
- Variable resistor input (5K-0 ohms).
- PMT functions available with use of line contactor.
- Current limit and controlled acceleration adjustable.
- Battery Discharge Indicator interrupt compatible.
- On-board TMM1A functions

Operation of voltage regulator card:

This card provides the basic functions required for controlling the EV100 hydraulic control and optional contactors and PMT functions. Battery positive is applied through a main control fuse to the key switch, energizing the control card power supply input to TB4.

When the line contactor is used, PMT operation is the same as outlined for the EV100 traction controllers.

The four speed ( motor volts ) reference points TB2, TB3, TB5, and TB6 are selected by connecting these points independently to battery negative.

The first speed is obtained by closing speed point 1, TB2, to SCR control negative. Speed point 1 is adjustable by function 11 to adjust motor voltage from 0 to full motor volts. The specified motor volts will be regulated, however, the magnitude of motor current will vary depending on the loading of the vehicle.

The second speed is obtained by closing speed point 2, TB3, to SCR control negative. Speed point 2 is adjustable by function 12 to adjust motor voltage form 0 to full motor volts.

The third speed is obtained by closing speed point 3, TB5, to SCR control negative. Speed point 3 is adjustable by function 13 to adjust motor voltage form 0 to full motor volts.

The fourth speed is obtained by closing speed point 4, TB6, to SCR control negative. Speed point 4 is non-adjustable and provides full control motor volts. Speed input 4 must be activated to enable the optional 1A contactor.

If more than one speed input is activated, the selected speed with the highest motor volts will override the low motor volt speed.

The 1A contactor is activated by closing the speed input switch connected to TB6 and SCR negative. This starts the time delay circuit of the 1A contactor. This time is trimpot adjustable from 1 to 4 seconds. A clockwise rotation of the trimpot will increase the time delay.

The current limit circuit is adjustable and operates the same as the traction SCR current limit. See

current limit curves for limits and range.

The controlled acceleration circuit is adjustable and operates the same as the traction SCR circuit. Adjustment range is from 0.45 to 4.0 seconds.

The variable resistor input will override the fixed motor volt limits set by the three adjustable speed inputs. It will vary motor volts above the set limits up to full motor volts, as resistance is decreased.

The Battery Discharge Indicator ( BDI ) interrupt will disable the hydraulic controller if the connection between PB3 and PB6 is opened. If a BDI circuit is not used, a jumper must be placed between PB3 and PB6 to allow the hydraulic control to operate.

The following are the input/output terminals for the pump control.

TB1	-	Accelerator Input
TB2	-	SL1 Input
TB3	-	SL2 Input
TB4	-	Key Switch Input
TB5	-	SL3 Input
TB6	-	SL4 Input
PA1	-	93 Status Code Input
PA2	-	93 Status Code Input
PA3	-	90 Status Code Input
PA4	-	94 Status Code Input
PA5	-	94 Status Code Input
PA6	-	91 Status Code Input
PB1	-	95 Status Code Input
PB2	-	95 Status Code Input
PB3	-	BDI Enable Signal
PB4	-	PMT Driver
PB5	-	1A Driver
PB6	-	92 Status Code Input
PY10	-	Input to Traction PY10
PY11	-	Input to Traction PY9
PY12	-	Input to Traction PY8

## GENERAL MAINTENANCE INSTRUCTIONS

The SCR control, like all electrical apparatus, does have some thermal losses. The semiconductor junctions have finite temperature limits above which these devices may be damaged. For these reasons, normal maintenance should guard against any action which will expose the components to excessive heat, such as steam cleaning; or which will reduce heat dissipating ability of the control, such as restricting air flow.

The following DO'S and DON'TS should be observed:

Any controls that will be used in ambients of 100 F (40 C) or over should be brought to the attention of the truck manufacturer.

All external components having inductive coils must be filtered. Refer to vehicle manufacturer for specifications.

The control should not be steam cleaned. In dusty areas, use low-pressure air to blow off the control. In oily or greasy areas, a mild solution of detergent or denatured alcohol can be used to wash off the control and then blow completely dry with low-pressure air. The control can also be cleaned with Freon TF degreaser.

For the SCR panel to be most effective, it must be mounted against the frame of the truck. The truck frame, acting as an additional heat sink, will give improved truck performance by keeping the SCR control package cooler. The use of a heat-transfer grease (Dow Corning 340) is recommended.

Terminal boards and other exposed SCR control parts should be kept free of dirt and paint that might change the effective resistance between points.

**CAUTION: The truck should not be plugged when the truck is jacked up and the drive wheels are in a free wheeling position. The higher motor speeds can create excessive voltages that can be harmful to the control.**

Do not hipot (or megger) the control. Unless the terminals of each semiconductor and card are connected together, the control may be damaged. Refer to control manufacturer before hipotting.

Use a lead-acid battery with the voltage and ampere hour rating specified for the vehicle. Follow normal battery maintenance procedures, recharging before 80 percent discharged and with periodic equalizing charges.



## TROUBLE-SHOOTING INSTRUCTIONS

Trouble-shooting the EV100/200 LX/LXT control should be quick and easy by following the instruction outlined in the following status code instruction sheets.

If mis-operation of the vehicle occurs, a status code will be displayed on the Dash Display for vehicle equipped with a Dash Display or by plugging a Handset into logic card's plug "Y" location and then reading the status code.

With the status code number, follow the procedures outlined in the status code instruction sheets to determine the problem.

Checking and replacement of components are also outlined in sections of this instruction book. Please refer to these section as needed.

**Important Note:** Due to the interaction of the logic card with all vehicle functions, almost any status code or control fail could be caused by the logic card. After all other status code procedures have been followed and no problem is found the logic card should then be replaced as the last option to correct problem.

The same device designations have been maintained on different controls but the wire numbers may vary. Refer to the elementary and wiring diagrams for your specific control. The wire numbers shown on the elementary diagram will have identical numbers on the corresponding wiring diagrams for a specific truck, but these numbers may be different from the numbers referenced in this publication.

**WARNING: Before trouble-shooting, jack up wheels, disconnect the battery and discharge capacitor 1C. Reconnect the battery as needed for the specific check.**

If capacitor 1C terminals are not accessible, discharge capacitor by connecting from SCR POS terminal to 2 REC anode. Check resistance on Rx1000 scale from frame to SCR power and control terminals. A resistance of less than 20,000 ohms can cause misleading symptoms. Resistance less than 1000 ohms should be corrected first.

Before proceeding, visually check for loose wiring, maladjusted linkage to the accelerator switch, signs of overheating of components, etc.

Tools and test equipment required are: (a) 6-volt lamp, 6-volt battery, two A14 diodes (1 Amp 400V), clip leads, volt-ohm meter (20,000 ohms per volt) and general hand tools.

**PAGE INTENTIONALLY LEFT BLANK**



**GE Electric Vehicle  
Systems**

## INSTRUCTIONS STATUS CODES

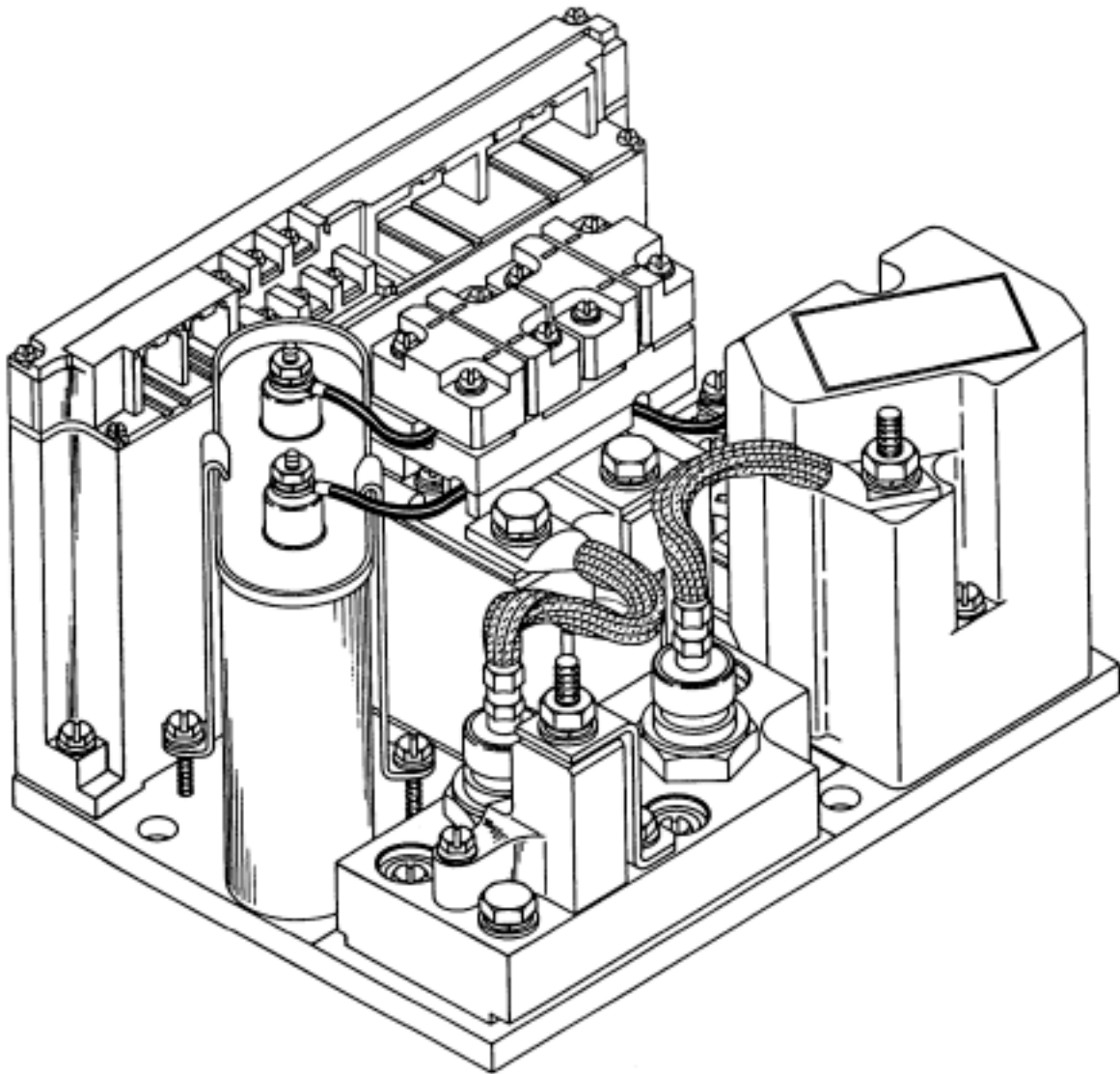

The information contained herein is intended to assist truck users and dealers in the servicing of Solid-State controls furnished by the General Electric Company. It does not purport to cover all variations in equipment nor to provide for every possible contingency to be met with installation, operation or maintenance.

Should further information be desired or should particular problems arise which are not covered sufficiently for the purchaser's purpose, the matter should be referred to the vehicle manufacturer through his normal service channels, not directly to the General Electric Company.

STATUS CODE <b>BLANK DISPLAY</b>	DESCRIPTION	MEMORY RECALL	No
	Segments do not illuminate on Dash Display or Handset		CONTROL TYPE
<p><b>SYMPTOM</b> Display screen on Dash Display or Handset is blank.</p> <p><b>POSSIBLE CAUSE</b> Positive or negative control voltage is missing.</p> <ul style="list-style-type: none"> <li>Insure that the key switch is closed and voltage is present between PZ7 and PZ3 control negative , and that voltage is present between TB4 and PZ3 control negative.</li> </ul> <p>Open circuit between logic card plug "Y" and Dash Display or Handset.</p> <ul style="list-style-type: none"> <li>Check for a loose connection or open wire between logic card plug "Y" and Dash Display or Handset.</li> </ul> <p>Defective Dash Display or Handset</p> <ul style="list-style-type: none"> <li>Replace Dash Display or Handset.</li> </ul>		<p style="text-align: center;">Figure 1</p> <p style="text-align: center;"><b>STATUS INDICATION CRITERIA</b> This indicates a lack of input voltage to the logic card and/or display unit.</p>	

STATUS CODE <b>-01</b>	DESCRIPTION	MEMORY RECALL	No
	No seat/deadman switch input.		CONTROL TYPE
<p><b>SYMPTOM</b> Forward or reverse contactor will not pick up.</p> <p><b>POSSIBLE CAUSE</b> Mis-adjusted or defective seat switch.</p> <ul style="list-style-type: none"> <li>Check seat switch to insure proper closure.</li> </ul> <p>Open circuit between battery positive TB3.</p> <ul style="list-style-type: none"> <li>Check for loose connections or broken wire between seat switch and TB3 and between key switch and positive side of the seat switch and seat switch to TB4.</li> <li>On vehicles without seat switch, check for loose connections or broken wire from TB4 to TB3.</li> </ul>		<p style="text-align: center;">Figure 1</p> <p style="text-align: center;"><b>STATUS INDICATION CRITERIA</b> This status code will be displayed when TB3 is less than 50% battery volts.</p>	

<b>STATUS CODE</b> <b>-02</b>	<b>DESCRIPTION</b>	<b>MEMORY RECALL</b>	No
	Forward directional switch is closed on initial power up.	<b>CONTROL TYPE</b>	Traction

<p style="text-align: center;"><b>SYMPTOM</b></p> <p>Forward contactor will not close because of Static Return to Off (SRO) lock out.</p> <p style="text-align: center;"><b>POSSIBLECAUSE</b></p> <p>Forward directional switch is closed on initial start up (i.e. closure of battery, key switch or seat/deadman switch).</p> <ul style="list-style-type: none"> <li>Return directional switch lever to neutral and then return lever to forward position.</li> </ul> <p>Forward directional switch is welded closed or mis-adjusted to be held closed.</p> <ul style="list-style-type: none"> <li>Replace or adjust directional switch to insure that it opens when the directional switch is returned to neutral.</li> </ul> <p>Short circuit between TB3 and TB5.</p> <ul style="list-style-type: none"> <li>Disconnect the wire from TB5 and check for a short circuit between TB3 and the wire.</li> </ul> <p>Defective logic card.</p> <ul style="list-style-type: none"> <li>Disconnect wire at TB5; Measure voltage at TB5, should be less than 60% of battery volts.</li> </ul>	<p style="text-align: center;"><b>Figure 1</b></p> <p style="text-align: center;"><b>STATUS INDICATION CRITERIA</b></p> <p>This status code will be displayed when TB5 is greater than 60% of battery volts on initial start up.</p>
--	--

<b>STATUS CODE</b> <b>-03</b>	<b>DESCRIPTION</b>	<b>MEMORY RECALL</b>	No
	Reverse directional switch is closed on initial power up.	<b>CONTROL TYPE</b>	Traction

<p style="text-align: center;"><b>SYMPTOM</b></p> <p>Reverse contactor will not close because of Static Return to Off (SRO) lock out.</p> <p style="text-align: center;"><b>POSSIBLECAUSE</b></p> <p>Reverse directional switch is closed on initial start up (i.e. closure of battery, key switch or seat/deadman switch).</p> <ul style="list-style-type: none"> <li>Return directional switch lever to neutral and then return lever to reverse position.</li> </ul> <p>Reverse directional switch is welded closed or mis-adjusted to be held closed.</p> <ul style="list-style-type: none"> <li>Replace or adjust directional switch to insure that it opens when the directional switch is returned to neutral.</li> </ul> <p>Short circuit between TB3 and TB6.</p> <ul style="list-style-type: none"> <li>Disconnect the wire from TB6 and check for a short circuit between TB3 and the wire.</li> </ul> <p>Defective logic card.</p> <ul style="list-style-type: none"> <li>Disconnect wire at TB6; Measure voltage at TB6, should be less than 60% of battery volts.</li> </ul>	<p style="text-align: center;"><b>Figure 1</b></p> <p style="text-align: center;"><b>STATUS INDICATION CRITERIA</b></p> <p>This status code will be displayed when TB6 is greater than 60% of battery volts on initial start up.</p>
--	--

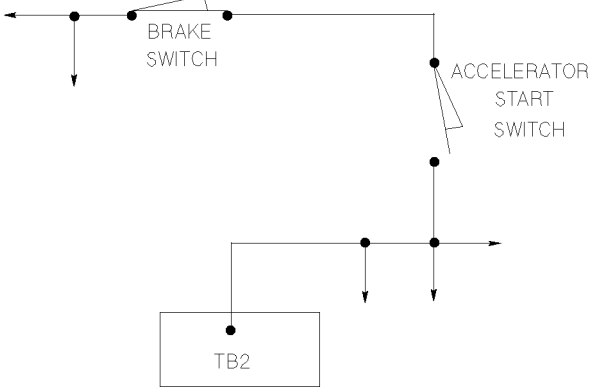
STATUS CODE <b>-04</b>	DESCRIPTION	MEMORY RECALL	No
		Start switch input low after initial start up	CONTROL TYPE
<p><b>SYMPTOM</b> Forward or reverse contactor will not pick-up.</p> <p><b>POSSIBLECAUSE</b> Forward or reverse directional switch closed on initial start up.</p> <ul style="list-style-type: none"> <li>Depress accelerator to close start switch. Status code will change to 03 if reverse directional switch or to 02 if forward directional switch is closed. If either of these codes appear, return directional switch to neutral and then select the desired direction.</li> </ul> <p>Excessive leakage from TB2 to battery negative.</p> <ul style="list-style-type: none"> <li>Check voltage at TB2 with key and seat switches closed and directional switch in neutral. Voltage should be greater than 60% of battery voltage.</li> <li>If less than 60% battery voltage. Remove wire and measure ohmic value from wire to SCR negative. Value should be less than 22k ohms.</li> </ul>		 <p><b>Figure 1</b></p> <p><b>STATUS INDICATION CRITERIA</b> This status code is displayed when TB2 voltage is less than 60% of battery volts at initial start-up (seat switch closure).</p>	

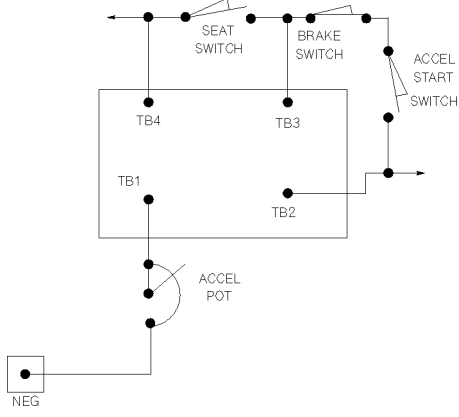
STATUS CODE <b>-05</b>	DESCRIPTION	MEMORY RECALL	No
		Start switch or brake switch fails to close.	CONTROL TYPE
<p><b>SYMPTOM</b> Forward or reverse contactor will not pick up.</p> <p><b>POSSIBLECAUSE</b> Defective brake switch circuit.</p> <ul style="list-style-type: none"> <li>Check brake switch to insure closure with brake pedal released.</li> <li>Check for open circuit or loose connections in wiring from brake switch to seat switch and TB3, and from brake switch to start switch.</li> </ul> <p>Defective start switch circuit.</p> <ul style="list-style-type: none"> <li>Check start switch to insure closure when accelerator is depressed.</li> <li>Check for open circuit or loose connections in wiring from brake switch to start switch and from TB2 to start switch.</li> </ul>		 <p><b>Figure 1</b></p> <p><b>STATUS INDICATION CRITERIA</b> This status code is when TB1 is less than 2.5 volts and TB2 is less than 60% battery volts.</p>	

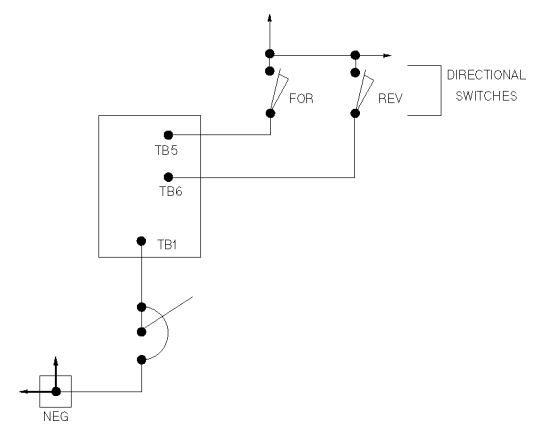
STATUS CODE <b>-06</b>	DESCRIPTION	MEMORY RECALL	No
	Accelerator depressed with no direction selected.		CONTROL TYPE
<p><b>SYMPTOM</b> Forward or reverse contactor will not pick up.</p> <p><b>POSSIBLE CAUSE</b> Accelerator pedal is depressed before closing forward or reverse directional switch.</p> <ul style="list-style-type: none"> <li>Status code will disappear when directional switch is closed or when accelerator pedal is released.</li> </ul> <p>Defective directional switch</p> <ul style="list-style-type: none"> <li>Check forward or reverse switch to insure closure when direction is selected.</li> </ul> <p>Open circuit between directional switch(s) and battery positive or between directional switch(s) and TB5 or TB6.</p> <ul style="list-style-type: none"> <li>Check all control wires and connections shown in Figure 1.</li> </ul>		 <p><b>Figure 1</b></p> <p><b>STATUS INDICATION CRITERIA</b> This status code will be displayed when TB5 and TB6 are less than 60% of the battery volts, and TB1 is less than 2.5 volts.</p>	

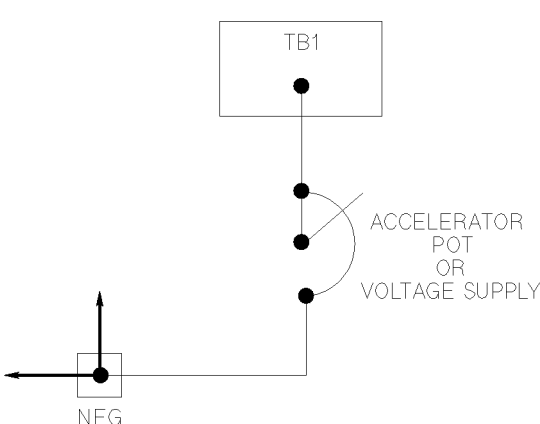
STATUS CODE <b>-07</b>	DESCRIPTION	MEMORY RECALL	No
	Accelerator input voltage too high.		CONTROL TYPE
<p><b>SYMPTOM</b> Forward or reverse contactor picks up but control will not operate when accelerator pedal is depressed or status code -07 is displayed then disappears when the vehicle starts to accelerate.</p> <p><b>POSSIBLE CAUSE</b> Accelerator input mis-adjusted or defective.</p> <ul style="list-style-type: none"> <li>Input voltage at TB1 should be less than 3.7 volts. Adjust or replace accelerator unit to insure that the voltage at TB1 will vary from 3.5 volts to less than .5 volts when the pedal is depressed.</li> </ul> <p>Open circuit between battery negative and TB1 in accelerator input circuit.</p> <ul style="list-style-type: none"> <li>Check for broken wires or loose connections or open potentiometer / voltage supply in the circuit shown in Figure 1.</li> </ul> <p>Short circuit from battery positive to wiring in accelerator input circuit.</p> <ul style="list-style-type: none"> <li>Disconnect wire from TB1 and measure voltage at wire to negative. Should be zero volts for potentiometer type and less than 3.7 volts for solid state type accelerator input.</li> </ul>		 <p><b>Figure 1</b></p> <p><b>STATUS INDICATION CRITERIA</b> This status code is displayed when the accelerator input voltage at TB1 is higher than 3.7 volts, and a directional contactor is picked up.</p>	

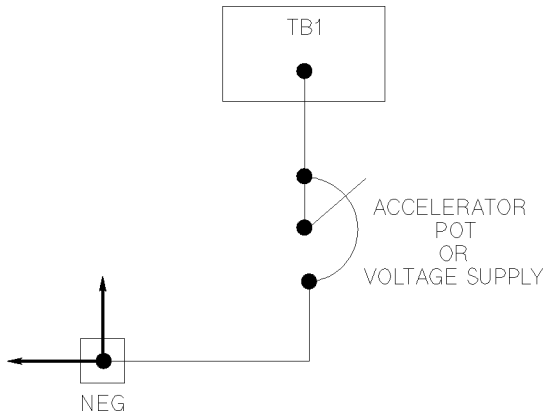
STATUS CODE <b>-08</b>	DESCRIPTION	MEMORY RECALL	No
	Accelerator input voltage too low on power up after initial key switch closure.	CONTROL TYPE	Traction
<p><b>SYMPTOM</b> Forward or reverse contactor does not pick up.</p> <p><b>POSSIBLE CAUSE</b> Accelerator input mis-adjusted or defective.</p> <ul style="list-style-type: none"> <li>Input voltage at TB1 should be more than 3.0 volts. Adjust or replace accelerator unit to insure that the voltage at TB1 is more than 3.0 volts before depressing pedal.</li> </ul> <p>Short circuit between battery negative and TB1 in accelerator input circuit.</p> <ul style="list-style-type: none"> <li>Disconnect wire from TB1. Check for short circuit from wire to battery negative. Resistance should be greater than 4.7K ohms.</li> </ul> <p>Defective Card</p> <ul style="list-style-type: none"> <li>Disconnect wire from TB1. Measure voltage from TB1 to negative. Voltage should be greater than 4.5 volts, if not, replace card.</li> </ul>		 <p><b>Figure 1</b></p> <p><b>STATUS INDICATION CRITERIA</b> This status code will be displayed when the accelerator input voltage at TB1 is less than 3.0 volts, and any of the following connections are opened and closed, battery plug or seat switch or key switch.</p>	

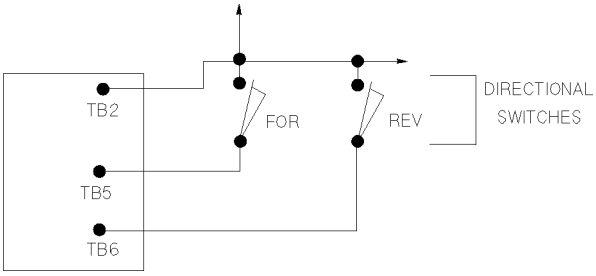
STATUS CODE <b>-09</b>	DESCRIPTION	MEMORY RECALL	No
	Both forward and reverse directional switches are closed at the same time.	CONTROL TYPE	Traction
<p><b>SYMPTOM</b> Forward or reverse contactor will not pick up.</p> <p><b>POSSIBLE CAUSE</b> Forward or reverse directional switch welded closed or mis-adjusted to be held closed.</p> <ul style="list-style-type: none"> <li>Replace or adjust directional switches to insure that they open when directional switch is returned to neutral.</li> </ul> <p>Short circuit between battery positive and TB5 and/or TB6.</p> <ul style="list-style-type: none"> <li>Disconnect wires from TB5 and TB6 and check wires for short circuit to positive side of directional switch.</li> </ul> <p>Defective card</p> <ul style="list-style-type: none"> <li>Disconnect wires and measure voltage at TB5 and TB6. Voltage should be less than 60% of battery volts.</li> </ul>		 <p><b>Figure 1</b></p> <p><b>STATUS INDICATION CRITERIA</b> This status code will be displayed when TB5 and TB6 are greater than 60% of battery volts at the same time.</p>	

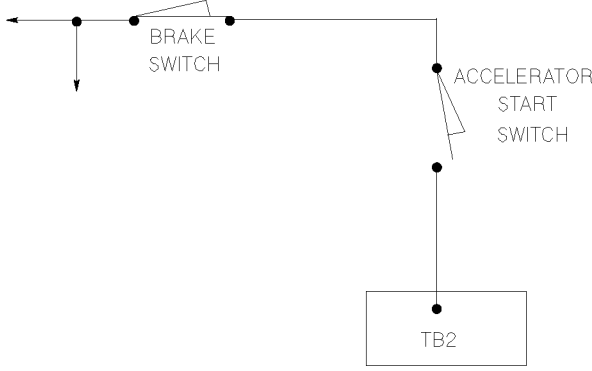

STATUS CODE <b>-11</b>	DESCRIPTION	MEMORY RECALL	No
	Start switch closed on power up after initial key switch closure. <b>IC3645LXCD1ZH and ZY logic cards only.</b>		CONTROL TYPE
<p><b>SYMPTOM</b> Forward or reverse contactor does not pick up.</p> <p><b>POSSIBLE CAUSE</b> Start switch input mis-adjusted or defective.</p> <ul style="list-style-type: none"> <li>Input voltage at TB2 should be less than 60% battery volts at key switch closing. Adjust or replace accelerator unit to insure that the voltage at TB2 is less than 60% battery volts before closing the start switch pedal.</li> </ul> <p>Short circuit between battery positive and TB2 in start switch input circuit.</p> <ul style="list-style-type: none"> <li>Disconnect wire from TB2. Check for short circuit from wire to battery positive. Resistance should be greater than 4.7K ohms.</li> </ul> <p>Defective Card</p> <ul style="list-style-type: none"> <li>Disconnect wire from TB3. Measure voltage from TB3 to negative. Voltage should be zero, if not, replace card.</li> </ul>		 <p style="text-align: center;">Figure 1</p> <p><b>STATUS INDICATION CRITERIA</b> This status code will be displayed when TB2 is greater than 60% battery volts when the key switch is closed.</p>	

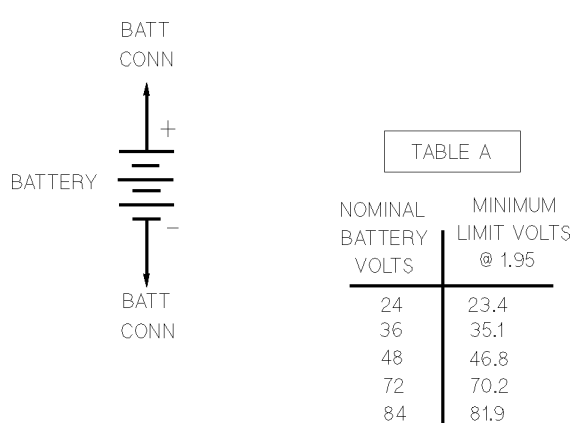
STATUS CODE <b>-15</b>	DESCRIPTION	MEMORY RECALL	No
	Battery volts too low.		CONTROL TYPE
<p><b>SYMPTOM</b> Forward or reverse contactor will not pick up.</p> <p><b>POSSIBLE CAUSE</b></p> <p>Discharged battery</p> <ul style="list-style-type: none"> <li>Check battery for proper open circuit voltage as outlined in figure 1 and charge battery if required.</li> </ul> <p>Defective battery</p> <ul style="list-style-type: none"> <li>Check each battery cell for proper voltage (greater than 1.95 volts at cell). Replace or repair battery.</li> </ul> <p>Incorrect control card adjustment.</p> <ul style="list-style-type: none"> <li>Check function 15 for proper adjustment for battery being used. See handset instruction sheet for details. Adjust to proper settings.</li> </ul>		 <p style="text-align: center;">Figure 1</p> <p><b>STATUS INDICATION CRITERIA</b> This status code is displayed when the battery volts are less than 1.95 volts per cell at initial start up. (See table in figure 1).</p>	

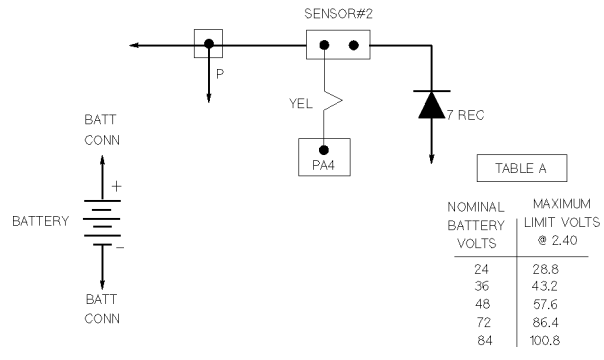
STATUS CODE <b>-16</b>	DESCRIPTION	MEMORY RECALL	No												
		Battery volts too high.	CONTROL TYPE	Traction											
<p><b>SYMPTOM</b> Forward and reverse contactor will not pick up.</p> <p><b>POSSIBLE CAUSE</b> Incorrect control card adjustment</p> <ul style="list-style-type: none"> <li>Check function 15 for proper adjustment for battery being used. See handset instructions for details. Adjust to proper setting.</li> </ul> <p>Battery over charged or incorrect battery used.</p> <ul style="list-style-type: none"> <li>Check battery for proper open circuit voltage per table in figure 1. If voltage excessive-check battery charger for proper output voltage.</li> </ul>		 <p><b>TABLE A</b></p> <table border="1"> <thead> <tr> <th>NOMINAL BATTERY VOLTS</th> <th>MAXIMUM LIMIT VOLTS @ 2.40</th> </tr> </thead> <tbody> <tr> <td>24</td> <td>28.8</td> </tr> <tr> <td>36</td> <td>43.2</td> </tr> <tr> <td>48</td> <td>57.6</td> </tr> <tr> <td>72</td> <td>86.4</td> </tr> <tr> <td>84</td> <td>100.8</td> </tr> </tbody> </table> <p><b>Figure 1</b></p>		NOMINAL BATTERY VOLTS	MAXIMUM LIMIT VOLTS @ 2.40	24	28.8	36	43.2	48	57.6	72	86.4	84	100.8
NOMINAL BATTERY VOLTS	MAXIMUM LIMIT VOLTS @ 2.40														
24	28.8														
36	43.2														
48	57.6														
72	86.4														
84	100.8														
		<p><b>STATUS INDICATION CRITERIA</b> This status code is displayed when the battery volts are greater than 2.40 volts per cell at initial start up. (See table in figure 1.)</p>													

STATUS CODE <b>-17</b>	DESCRIPTION	MEMORY RECALL	No
		Invalid card type selection.	CONTROL TYPE
<p><b>SYMPTOM</b> Forward or reverse contactors will not close.</p> <p><b>POSSIBLE CAUSE</b> Invalid card type selection.</p> <ul style="list-style-type: none"> <li>Review function 17 in the Handset Instruction sheets. Adjust and set card type value as instructed by OEM service manual.</li> </ul>		<p><b>NO DIAGRAM AVAILABLE FOR THIS STATUS CODE</b></p> <p><b>Figure 1</b></p>	
		<p><b>STATUS INDICATION CRITERIA</b> This status code is displayed when the card type selection value is set to an invalid number.</p>	

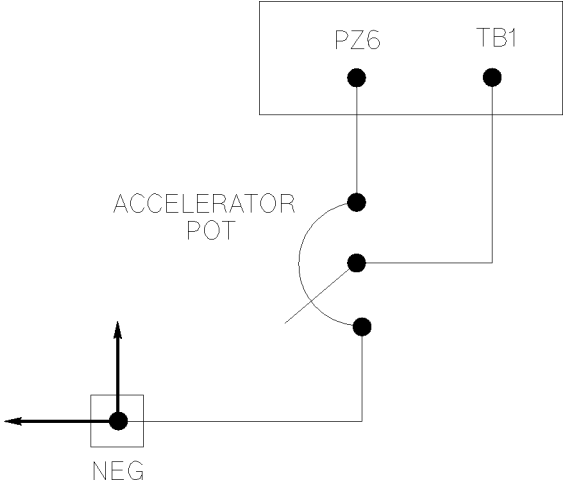
STATUS CODE <b>-21</b>	DESCRIPTION	MEMORY RECALL	No
	Accelerator input is less than .25 volts. <b>IC3645LXCD1ZH and ZY logic cards only.</b>		CONTROL TYPE
<p><b>SYMPTOM</b> Control will not operate.</p> <p><b>POSSIBLE CAUSE</b> Accelerator input mis-adjusted or defective.</p> <ul style="list-style-type: none"> <li>Input voltage at TB1 should be more than .25 volts. Adjust or replace accelerator unit to insure that the voltage at TB1 is more than .25 volts before depressing pedal.</li> </ul> <p>Short circuit between battery negative and TB1 in accelerator input circuit.</p> <ul style="list-style-type: none"> <li>Disconnect wire from TB1. Check for short circuit from wire to battery negative. Resistance should be greater than 4.7K ohms.</li> </ul> <p>Open circuit between accelerator and PZ6.</p> <ul style="list-style-type: none"> <li>Insure 5 volts is present from to PZ6 to potentiometer element.</li> </ul> <p>Defective Card</p> <ul style="list-style-type: none"> <li>Disconnect wire from TB1. Measure voltage from TB1 to negative. Voltage should be greater than 4.5 volts, if not, replace card.</li> </ul>		 <p><b>Figure 1</b></p> <p><b>STATUS INDICATION CRITERIA</b> This status code is displayed when the voltage at TB1 is less than .25 volts.</p>	

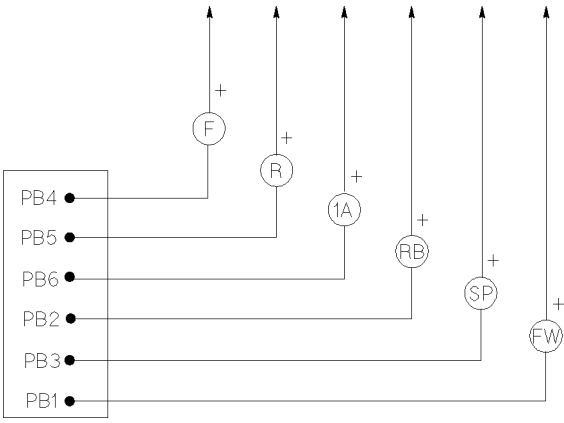
STATUS CODE <b>-23</b>	DESCRIPTION	MEMORY RECALL	No
	Forward and reverse contactor coil current low.		CONTROL TYPE
<p><b>SYMPTOM</b> Forward or reverse contactor will not pick up. Status code may alternate between code 23 and code 24. Complete check for code 23, if the problem is not found, perform check for code 24.</p> <p><b>POSSIBLE CAUSE</b> Defective F and R contactor coil circuit.</p> <ul style="list-style-type: none"> <li>Check for open circuit or loose connection between PB4 and positive side of F contactor coil and between PB5 and positive side of R contactor coil.</li> <li>Remove plug B. Check ohmic value from PB4 to positive side of F coil. Value should be 10-14 ohms. Make same check for R coil.</li> </ul> <p>Defective 1A, RB, SP, or FW contactor coil.</p> <ul style="list-style-type: none"> <li>Remove plug B. Check ohmic value from positive side of each coil to its respective plug connection. Value should be 10-14 ohms.</li> </ul>		 <p><b>Figure 1</b></p> <p><b>STATUS INDICATION CRITERIA</b> This status code is displayed when the current draw in the forward or reverse contactor coil circuit is less than 100 ma.</p>	

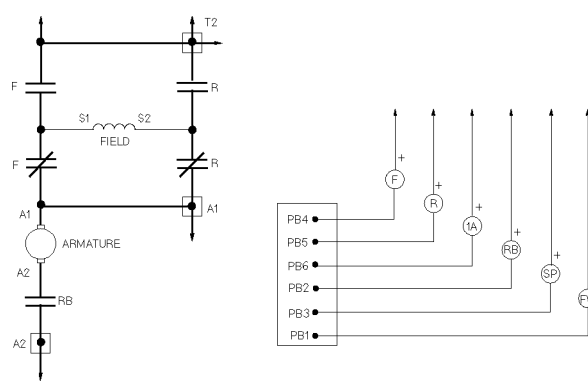
STATUS CODE <b>-24</b>	DESCRIPTION	MEMORY RECALL	No
		T2 voltage low. (Less than 12% battery volts.)	CONTROL TYPE
<p><b>SYMPTOM</b> SCR control does not operate. Status code may alternate between code 23 and code 24. Complete checks for 24, if the problem is not found, perform code 23 check.</p> <p><b>POSSIBLE CAUSE</b> Defective F or R contactor.</p> <ul style="list-style-type: none"> <li>F or R power tips fail to close because:           <ol style="list-style-type: none"> <li>1) Welded normally closed power tips.</li> <li>2) Binding contactor tip assembly.</li> <li>3) Defective F or R contactor coil. ( See status code 23)</li> </ol> </li> </ul> <p>Defective RB contactor.</p> <ul style="list-style-type: none"> <li>Check RB contactor power tips for closure and proper pick up.</li> <li>Check for open circuit or loose connections between positive side of RB contactor coil and PB2.</li> </ul> <p>Open motor circuit</p> <ul style="list-style-type: none"> <li>Check for open circuit or loose connection in motor circuit from the A1 connection to the A2 connection on the SCR control panel.</li> </ul> <p>Defective 1A, RB, SP or FW contactor</p> <ul style="list-style-type: none"> <li>Perform checks as outlined in status 23.</li> </ul>		 <p style="text-align: center;"><b>Figure 1</b></p> <p><b>STATUS INDICATION CRITERIA</b> This status code is displayed when T2 volts is greater than 12% of battery volts and the F and R driver is energized.</p>	

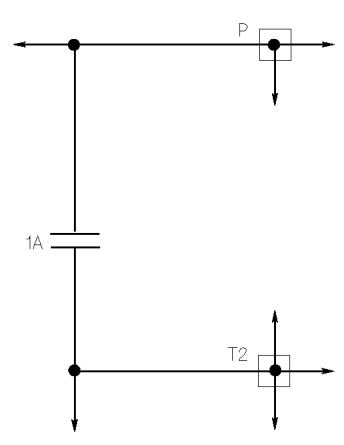
STATUS CODE <b>-25</b>	DESCRIPTION	MEMORY RECALL	Yes
		1A contactor does not drop out or drops out slowly.	CONTROL TYPE
<p><b>SYMPTOM</b> Short tip life on F and R or 1A contactor. Status code 46 displayed and no fault found.</p> <p><b>POSSIBLE CAUSE</b></p> <p>Note: This status code can only be found by using the handset and looking at function 1. This status code is furnished as a troubleshooting aid for status code 46.</p> <p>Defective 1A contactor</p> <ul style="list-style-type: none"> <li>Check 1A contactor for binding or slow operation when dropping out.</li> </ul>		 <p style="text-align: center;"><b>Figure 1</b></p> <p><b>STATUS INDICATION CRITERIA</b> This status code is displayed when 1A contactor drop out time exceeds .060 seconds.</p>	

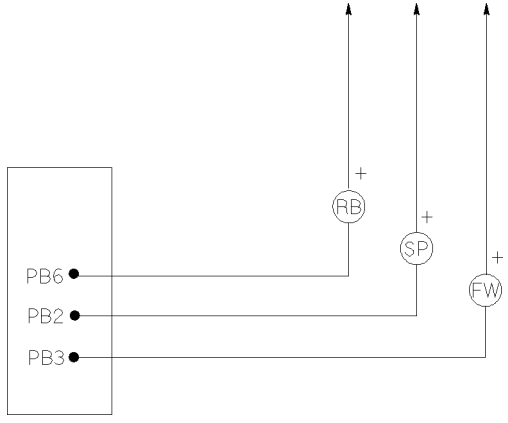
STATUS CODE <b>-26</b>	DESCRIPTION	MEMORY RECALL	No
	Shorted coil driver for SP or FW contactor.		CONTROL TYPE
<p><b>SYMPTOM</b> SP or FW contactor picks up immediately when key switch is closed.</p> <p><b>POSSIBLE CAUSE</b> Defective coil driver internal to logic card.</p> <ul style="list-style-type: none"> <li>Replace logic card.</li> </ul>		 <p>Figure 1</p>	
		STATUS INDICATION CRITERIA	
		This status code is displayed when there is a shorted RB, SP or FW coil driver.	

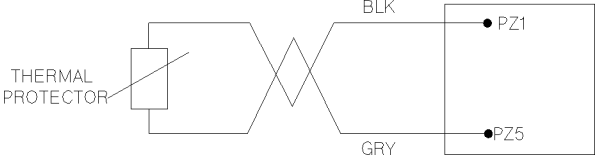
STATUS CODE <b>-41</b>	DESCRIPTION	MEMORY RECALL	No
	Open thermal protector (TP) or control over temperature.		CONTROL TYPE
<p><b>SYMPTOM</b> Reduced or no power to traction motor in SCR range.</p> <p><b>POSSIBLE CAUSE</b> Open thermal protector circuit.</p> <ul style="list-style-type: none"> <li>Check for loose connection or broken wire between: Black wire-Thermal proctor and PZ1. Gray wire-Thermal proctor and PZ5.</li> </ul> <p>Defective thermal protector.</p> <ul style="list-style-type: none"> <li>Disconnect wires from PZ1 and PZ5. At room temperature (25°C or 75°F) measure resistance between black and gray wire. Replace TP if ohmic value is greater than 300 ohms.</li> </ul> <p>SCR is in thermal cut-back.</p> <ul style="list-style-type: none"> <li>Allow control to cool, status code should disappear.</li> </ul>		 <p>Figure 1</p>	
		STATUS INDICATION CRITERIA	
		This status code is displayed when the voltage between PZ1 and PZ5 is greater than 1.8 volts.	

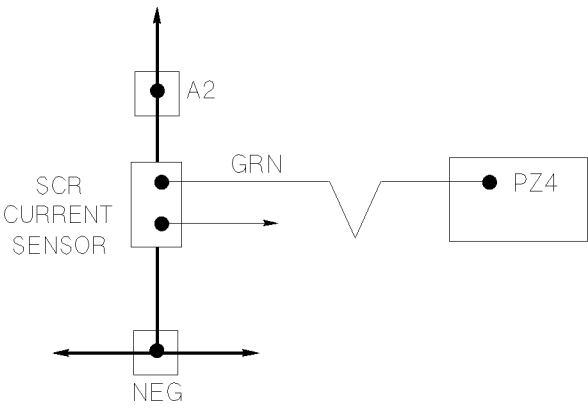
STATUS CODE <b>-42</b>	DESCRIPTION	MEMORY RECALL	No
	Control motor current sensor input missing.	CONTROL TYPE	Traction
<p><b>SYMPTOM</b> No power to traction motor in SCR range.</p> <p><b>POSSIBLE CAUSE</b> Open sensor wire circuit to PZ4.</p> <ul style="list-style-type: none"> <li>Check for loose connection or broken wire (green wire) from current sensor to PZ4 on the logic card.</li> </ul>		 <p style="text-align: center;">Figure 1</p>	
		<p><b>STATUS INDICATION CRITERIA</b> This status code is displayed when voltage between PY7 and negative is greater than 1.6 volts with no current flowing in the motor circuit.</p>	

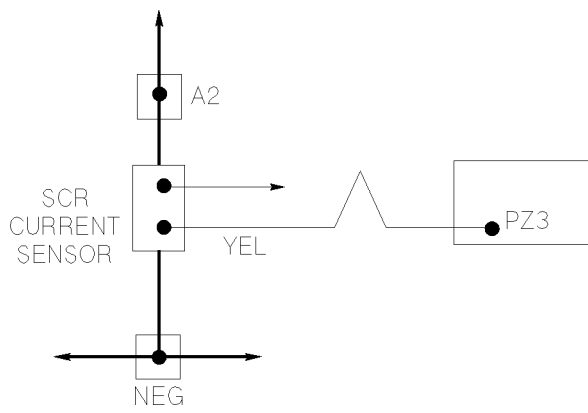
STATUS CODE <b>-43</b>	DESCRIPTION	MEMORY RECALL	No
	Control motor current sensor input missing.	CONTROL TYPE	Traction
<p><b>SYMPTOM</b> Stall currents in SCR range higher than normal and uncontrollable with C/L adjustment.</p> <p><b>POSSIBLE CAUSE</b> Open sensor wire circuit to PZ3.</p> <ul style="list-style-type: none"> <li>Check for loose connections or broken wire (yellow wire) from current sensor to PZ3 on logic card.</li> </ul>		 <p style="text-align: center;">Figure 1</p>	
		<p><b>STATUS INDICATION CRITERIA</b> This status code is displayed when voltage between PY7 and negative is less than .84 volts with no current flowing in motor circuit.</p>	

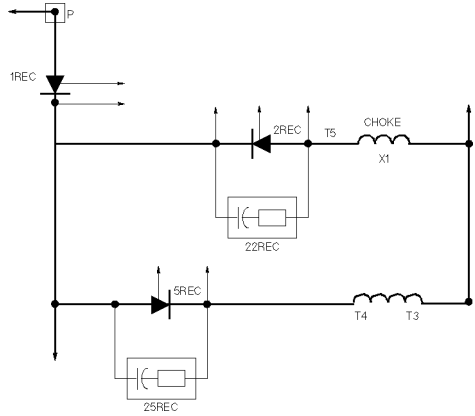
STATUS CODE <b>44</b>	DESCRIPTION	MEMORY RECALL	Yes
	1REC did not turn off properly.	CONTROL TYPE	Traction
<p><b>SYMPTOM</b></p> <p>Forward or reverse contactors open and close, then can only be closed by opening and closing the key switch.</p> <p><b>POSSIBLE CAUSE</b></p> <p>Defective 5 REC circuit.</p> <ul style="list-style-type: none"> <li>• Check for shorted 5 REC.</li> <li>• Check for shorted 5 REC snubber (25 REC).</li> </ul> <p>Defective 2 REC circuit.</p> <ul style="list-style-type: none"> <li>• Check for shorted 2 REC.</li> <li>• Check for shorted 2 REC snubber (22 REC).</li> </ul> <p>Open choke (1X).</p> <ul style="list-style-type: none"> <li>• Check for open circuit between T5 and T3. Ohm meter should read zero ohms.</li> </ul> <p>1 REC defective.</p> <ul style="list-style-type: none"> <li>• Turn off time for 1 REC out of specification. No field test is possible. Replace 1 REC after above checks, show no problem found.</li> </ul>		 <p><b>Figure 1</b></p> <p><b>STATUS INDICATION CRITERIA</b></p> <p>This status code is displayed when, during SCR operation, 1 REC fails to turn off.</p>	

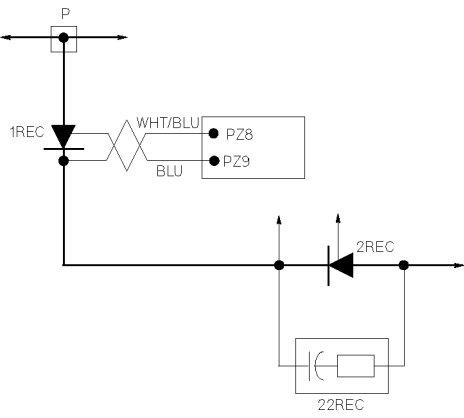
STATUS CODE <b>45</b>	DESCRIPTION	MEMORY RECALL	Yes
	1 REC did not turn on properly.	CONTROL TYPE	Traction
<p><b>SYMPTOM</b></p> <p>Forward or reverse contactor will open and close, then open and then can only be closed by opening and closing the key switch.</p> <p><b>POSSIBLE CAUSE</b></p> <p>Defective 2 REC circuit.</p> <ul style="list-style-type: none"> <li>• Check for shorted 2 REC.</li> <li>• Check for shorted 2 REC snubber (22 REC).</li> </ul> <p>Defective 1 REC circuit.</p> <ul style="list-style-type: none"> <li>• Check for open circuit or loose connections between 1REC and PZ8. (white/blue wire)</li> <li>• Check for open circuit or loose connection between 1REC (3 REC snubber) and PZ9. (blue wire)</li> </ul> <p>Defective 1 REC.</p> <ul style="list-style-type: none"> <li>• Intermittent or open 1 REC gate. Field test may or may not show defect. Replace 1 REC after above checks, show no problem found.</li> </ul>		 <p><b>Figure 1</b></p> <p><b>STATUS INDICATION CRITERIA</b></p> <p>This status code is displayed when 1 REC fails to gate on.</p>	

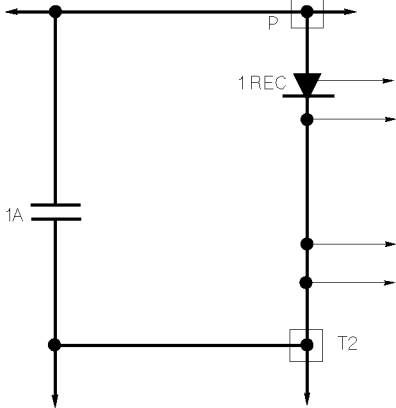
STATUS CODE <b>-46</b>	DESCRIPTION	MEMORY RECALL	No
	Look ahead test for T2 volts. ( Greater than 85% of battery volts)		CONTROL TYPE
<p><b>SYMPTOM</b> Forward or reverse contactor will not pick up.</p> <p><b>POSSIBLE CAUSE</b> Defective 1 REC.  <ul style="list-style-type: none"> <li>• Check for shorted 1 REC.</li> <li>• Check for defective 1 REC insulator (co-therm) that may short 1 REC heat sink to base plate.</li> </ul> Defective 1A contactor.  <ul style="list-style-type: none"> <li>• Check for welded 1A contactor power tips.</li> </ul> </p>		 <p style="text-align: center;">Figure 1</p>	
		STATUS INDICATION CRITERIA	
		This status code is displayed when the voltage at T2 is greater than 85% of battery volts.	

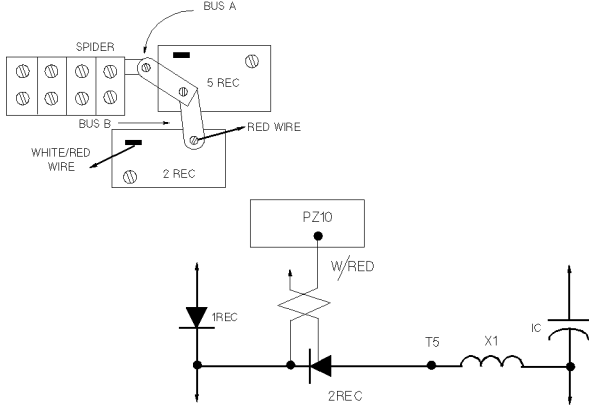
STATUS CODE <b>-47</b>	DESCRIPTION	MEMORY RECALL	No
	2REC does not turn properly		CONTROL TYPE
<p><b>SYMPTOM</b> Forward or reverse contactor will open and close, then open and then can only be closed by opening and closing the key switch.</p> <p><b>POSSIBLE CAUSE</b> Defective 2 REC circuit.  <ul style="list-style-type: none"> <li>• Check that 2 REC will gate on.</li> <li>• Check for open circuit or loose connection between 2 REC gate and PZ10. (white/red wire)</li> <li>• Check for open circuit or loose connection 1 REC and 1C through the 2 REC circuit.</li> </ul> F or R contactor or power tips bouncing open.  <ul style="list-style-type: none"> <li>• Check that power tips on F and R contactor power tips do not bounce open during operation (ie: travel over speed bumps or dock plates).</li> </ul> </p>		 <p style="text-align: center;">Figure 1</p>	
		STATUS INDICATION CRITERIA	
		This status code is displayed when the 2 REC fails to turn on.	

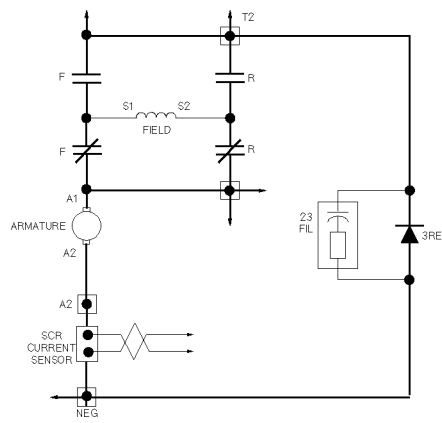

STATUS CODE <b>-48</b>	DESCRIPTION	MEMORY RECALL	No
		Look ahead test for T2 volts. (Less than 12% of battery volts)	CONTROL TYPE
<p><b>SYMPTOM</b> Forward or reverse contactor will not pick up.</p> <p><b>POSSIBLE CAUSE</b> Defective forward or reverse contactor.</p> <ul style="list-style-type: none"> <li>• Check for welded forward or reverse contactor power tips.</li> <li>• Check for sluggish operation of forward or reverse contactor.</li> </ul> <p>Defective 3 REC circuit.</p> <ul style="list-style-type: none"> <li>• Check for shorted 3 REC.</li> <li>• Check for shorted 3 REC snubber (23 REC).</li> </ul>		 <p><b>Figure 1</b></p> <p><b>STATUS INDICATION CRITERIA</b> This status code is displayed when the voltage at T2 is less than 12% of battery volts.</p>	

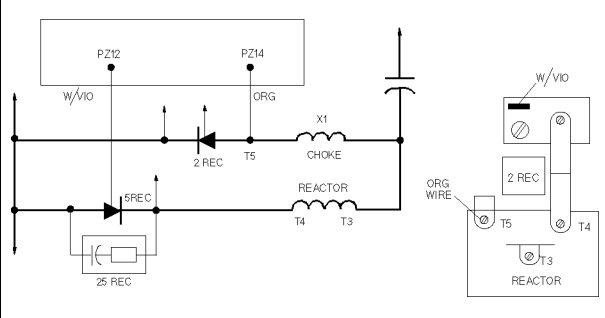
STATUS CODE <b>-49</b>	DESCRIPTION	MEMORY RECALL	No
		5 REC does not turn on properly	CONTROL TYPE
<p><b>SYMPTOM</b> Forward or reverse contactor will open and close, then open and then can only be closed by opening and closing the key switch.</p> <p><b>POSSIBLE CAUSE</b> Defective 5 REC circuit</p> <ul style="list-style-type: none"> <li>• Check for shorted 5 REC.</li> <li>• Check for shorted 5 REC snubber ( 25 REC ).</li> <li>• Check that 5 REC will gate on.</li> <li>• Check for open circuit or loose connection between 5 REC gate and PZ12 ( white/violet wire ).</li> </ul> <p>Shorted 2 REC circuit.</p> <ul style="list-style-type: none"> <li>• Check 2 REC and 2 REC snubber ( 22 REC ) for short circuit.</li> </ul> <p>Defective capacitor circuit.</p> <ul style="list-style-type: none"> <li>• Check for open capacitor.</li> <li>• Check for loose connections at capacitor terminals.</li> </ul>		 <p><b>Figure 1</b></p> <p><b>STATUS INDICATION CRITERIA</b> This status code is displayed when the 5 REC circuit fails to turn on.</p>	

STATUS CODE <b>-50</b>	DESCRIPTION	MEMORY RECALL	No
	Capacitor volts low .	CONTROL TYPE	Traction
<p><b>SYMPTOM</b> Forward or reverse contactor picks up. Control does not operate.</p> <p><b>POSSIBLE CAUSE</b> Defective 2 REC circuit.</p> <ul style="list-style-type: none"> <li>• Open circuit or loose connection between spider assembly and 5 REC (BUS A).</li> <li>• Open circuit or loose connection between 5 REC and 2 REC.</li> <li>• Open circuit or loose connection between 2 REC and PZ11 (red wire) and between 2 REC gate and PZ10 (white/red wire).</li> <li>• Check 2 REC to insure that it will gate on.</li> </ul>		<p><b>Figure 1</b></p> <p><b>STATUS INDICATION CRITERIA</b> This status code is displayed when 2 REC circuit fails to turn on at initial start up.</p>	

STATUS CODE <b>-51</b>	DESCRIPTION	MEMORY RECALL	No
	Excessive capacitor voltage when motor current is high.	CONTROL TYPE	Traction
<p><b>SYMPTOM</b> Forward or reverse contactors open and close, then can only be closed by opening and closing the key switch.</p> <p><b>POSSIBLE CAUSE</b> Excessive source inductance.</p> <ul style="list-style-type: none"> <li>• Tag lines without filters are being used.</li> <li>• Battery cables are too long.</li> </ul> <p>High peak current in motor.</p> <ul style="list-style-type: none"> <li>• Check for shorted field winding.</li> <li>• Check for shorted armature winding.</li> </ul>		<p><b>Figure 1</b></p> <p><b>STATUS INDICATION CRITERIA</b> This status code is displayed when capacitor volts exceed 225 volts and motor current is greater than 300 amps.</p>	

STATUS CODE <b>-52</b>	DESCRIPTION	MEMORY RECALL	Yes
	Excessive capacitor voltage when motor current is low.		CONTROL TYPE

<p><b>SYMPTOM</b></p> <p>Forward or reverse contactors open and close, then can only be closed by opening and closing the key switch.</p> <p><b>POSSIBLE CAUSE</b></p> <p>Excessive source inductance.</p> <ul style="list-style-type: none"> <li>• Tag lines without filters are being used.</li> <li>• Battery cables are too long.</li> </ul> <p>Defective 4 REC circuit.</p> <ul style="list-style-type: none"> <li>• Check for shorted 4 REC.</li> <li>• Check for open circuit or loose connection in 4 REC circuit.</li> </ul> <p>Defective 3 REC circuit.</p> <ul style="list-style-type: none"> <li>• Check for open circuit or loose connection in 3 REC circuit.</li> </ul>	 <p style="text-align: center;"><b>Figure 1</b></p> <p><b>STATUS INDICATION CRITERIA</b></p> <p>This status code is displayed when capacitor volts exceed 225 volts and motor current is less than 200 amps</p>
--	---

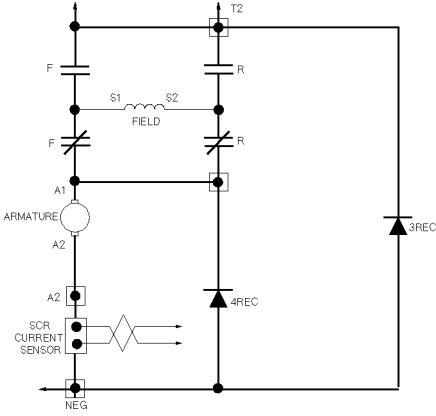
STATUS CODE <b>-53</b>	DESCRIPTION	MEMORY RECALL	Yes
	1 REC fails to turn off during plug cycle.		CONTROL TYPE

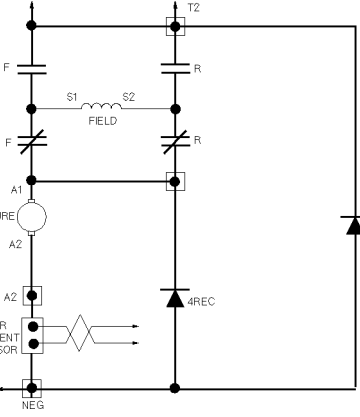

<p><b>SYMPTOM</b></p> <p>Forward or reverse contactor opens and closes, then opens and can only close by opening and closing the key switch.</p> <p><b>POSSIBLE CAUSE</b></p> <p>1 REC turn off failure not related to plugging.</p> <ul style="list-style-type: none"> <li>• Stall vehicle in both directions and note any status codes displayed that may more closely define the failure mode. Troubleshoot per new status code.</li> </ul> <p>1 REC turn off related to plugging.</p> <ul style="list-style-type: none"> <li>• Check 4 REC circuit for open 4 REC, loose or open cable/bus connections.</li> <li>• Check current sensor for loose or open connection in power circuit. Check yellow and green wire from sensor to logic card for open and loose connection.</li> </ul> <p>Defective motor circuit.</p> <ul style="list-style-type: none"> <li>• Check motor circuit for open or loose connections.</li> <li>• Check motor brushes for proper seating.</li> </ul> <p>F or R contactor power bouncing open.</p> <ul style="list-style-type: none"> <li>• Insure that F and R contactor does not bounce open during vehicle operation (ie: traveling over speed bumps and dock plates).</li> </ul>	 <p style="text-align: center;"><b>Figure 1</b></p> <p><b>STATUS INDICATION CRITERIA</b></p> <p>This status code is displayed when any failure of 1 REC to turn off during plug cycle.</p>
---	--

STATUS CODE <b>-54</b>	DESCRIPTION	MEMORY RECALL	No
	Shorted F, R or 1A contactor coil driver.		CONTROL TYPE
<p><b>SYMPTOM</b> Control will not operate.</p> <p><b>POSSIBLE CAUSE</b> Defective logic card.</p> <ul style="list-style-type: none"> <li>• Replace logic card.</li> </ul>		<p><b>NO DIAGRAM AVAILABLE FOR THIS STATUS CODE</b></p>	
		<p>Figure 1</p> <p><b>STATUS INDICATION CRITERIA</b> This status code is displayed when either the forward, reverse or 1A contactor coil driver is shorted internal to the logic card.</p>	

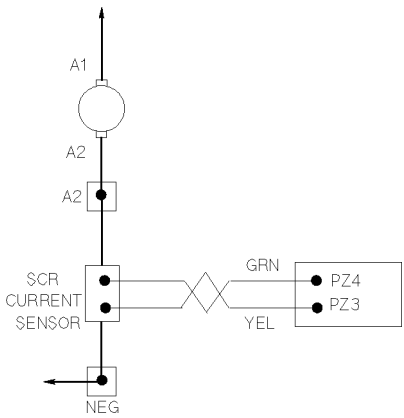
STATUS CODE <b>-57</b>	DESCRIPTION	MEMORY RECALL	No
	Current sensor input voltage polarity check.		CONTROL TYPE
<p><b>SYMPTOM</b> Forward or reverse contactors open and close, then can only be closed by opening and closing the key switch.</p> <p><b>POSSIBLE CAUSE</b> Reversed yellow and green current sensors wires</p> <ul style="list-style-type: none"> <li>• Insure that the: -green wire connects to PZ4 with no open circuits.</li> <li>-yellow wire connects to PZ3 with no open circuits or loose connections.</li> </ul> <p>Reversed power cable connection.</p> <ul style="list-style-type: none"> <li>• Insure that the battery negative cable connects to SCR NEG and the motor A2 cable connects to SCR A2.</li> </ul>			
		<p>Figure 1</p> <p><b>STATUS INDICATION CRITERIA</b> This status code is displayed when the voltage input to PZ4 and PZ3 is the wrong polarity.</p>	

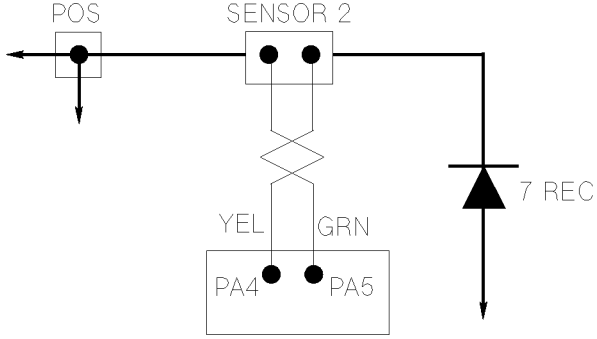
STATUS CODE <b>-70</b>	DESCRIPTION	MEMORY RECALL	Yes
	Regen current sensor input missing ( yellow wire ).		CONTROL TYPE
<p><b>SYMPTOM</b> Control does not operate.</p> <p><b>POSSIBLE CAUSE</b> Defective regen sensor input circuit.</p> <ul style="list-style-type: none"> <li>• Check yellow sensor wire for open circuit or loose connection between sensor (welded connection) and PA4.</li> </ul>		 <p style="text-align: center;">Figure 1</p>	
		STATUS INDICATION CRITERIA	
		This status code is displayed when input signal at PA4 is missing.	

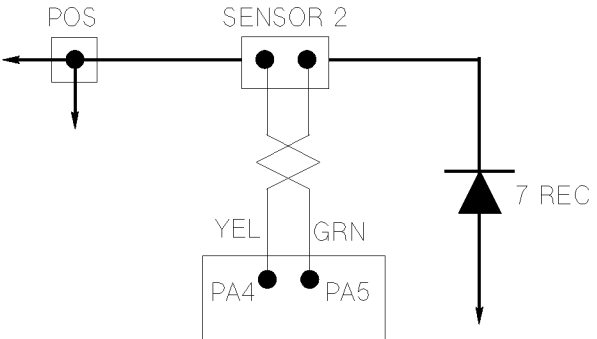
STATUS CODE <b>-71</b>	DESCRIPTION	MEMORY RECALL	Yes
	Regen current sensor input missing ( green wire ).		CONTROL TYPE
<p><b>SYMPTOM</b> Control does not operate.</p> <p><b>POSSIBLE CAUSE</b> Defective regen sensor input circuit.</p> <ul style="list-style-type: none"> <li>• Check green sensor wire for open circuit or loose connection between sensor (welded connection) and PA5.</li> </ul>		 <p style="text-align: center;">Figure 1</p>	
		STATUS INDICATION CRITERIA	
		This status code is displayed when input signal at PA5 is missing.	

STATUS CODE <b>-72</b>	DESCRIPTION	MEMORY RECALL	Yes	
	Regen contactor does not pick up.		CONTROL TYPE	Traction
<p><b>SYMPTOM</b> Regen control does not operate.</p> <p><b>POSSIBLE CAUSE</b> Open connection in the PA6 circuit.</p> <ul style="list-style-type: none"> <li>• Check for open circuit or loose connection between PA6 and the A2 connection of the RB contactor.</li> <li>• Check for open circuit or loose connection between 7 REC and the A2 connection of the RB contactor.</li> </ul>		<p style="text-align: center;">Figure 1</p>		
		STATUS INDICATION CRITERIA	This status code is displayed when logic card is in run mode and 2.5 volts or greater is present at PA6.	

STATUS CODE <b>-73</b>	DESCRIPTION	MEMORY RECALL	Yes	
	Regen contactor does not drop out or drops out slowly.		CONTROL TYPE	Traction
<p><b>SYMPTOM</b> Forward or reverse contactor opens and closes, then opens and can only close by opening and closing the key switch.</p> <p><b>POSSIBLE CAUSE</b> Defective RB contactor.</p> <ul style="list-style-type: none"> <li>• Check RB contactor for smoothness of operation and excessive wear on moving parts.</li> </ul> <p>Intermittent PA6 input.</p> <ul style="list-style-type: none"> <li>• Check for loose connections in PA6 circuit from PA6 to RB contactor A2 connection.</li> </ul>		<p style="text-align: center;">Figure 1</p>		
		STATUS INDICATION CRITERIA	This status code is displayed when the RB contactor power tips fail to open after 100 milliseconds after power is removed from the RB contactor coil.	

STATUS CODE <b>-74</b>	DESCRIPTION	MEMORY RECALL	Yes
	Regen contactor picks up too slow.		CONTROL TYPE
<p><b>SYMPTOM</b></p> <p>Forward or reverse contactor opens and closes, then opens and can only close by opening and closing the key switch.</p> <p><b>POSSIBLE CAUSE</b></p> <p>Defective RB contactor.</p> <ul style="list-style-type: none"> <li>• Check RB contactor for smoothness of operation and excessive wear on moving parts.</li> </ul> <p>Intermittent PA6 input.</p> <ul style="list-style-type: none"> <li>• Check for loose connections in PA6 circuit from PA6 to RB contactor A2 connection.</li> </ul> <p>Defective RB contactor coil circuit.</p> <ul style="list-style-type: none"> <li>• Check RB contactor coil for proper ohmic value. It should be 10-14 ohms.</li> <li>• Check coil connection from PB2 to RB coil (-) for loose connections.</li> <li>• Check coil connections from battery positive to RB coil (+) for loose connections.</li> </ul>		<p style="text-align: center;"><b>Figure 1</b></p> <p style="text-align: center;"><b>STATUS INDICATION CRITERIA</b></p> <p>This status code is displayed when the RB contactor power tips do not close within 100 milliseconds after power is applied to the RB contactor coil.</p>	

STATUS CODE <b>-75</b>	DESCRIPTION	MEMORY RECALL	Yes
	1 REC fails to turn off during Regen.		CONTROL TYPE
<p><b>SYMPTOM</b></p> <p>Forward or reverse contactor opens and closes, then opens and can only close by opening and closing the key switch.</p> <p><b>POSSIBLE CAUSE</b></p> <p>1 REC turn off failure not related to regen.</p> <ul style="list-style-type: none"> <li>• Stall vehicle in both directions and note any status codes displayed that may more closely define the failure mode. Trouble shoot per new status code.</li> </ul> <p>1 REC turn off related to regen.</p> <ul style="list-style-type: none"> <li>• Check for loose connections on all regen power circuits from battery positive to RB contactor A2 connection.</li> <li>• Check for loose connection on the following regen input circuits. <ul style="list-style-type: none"> <li>• Yellow wire from sensor 2 to PA4.</li> <li>• Green wire from sensor 2 to PA5.</li> <li>• Wire 17 from RB contactor to PA6.</li> </ul> </li> </ul> <p>Defective motor circuit.</p> <ul style="list-style-type: none"> <li>• Check motor circuit for open or loose connections.</li> <li>• Check motor brushes for proper seating.</li> </ul> <p>F or R contactor power bouncing open.</p> <ul style="list-style-type: none"> <li>• Insure that F and R contactor does not bounce open during vehicle operation (ie: traveling over speed bumps and dock plates).</li> </ul>		<p style="text-align: center;"><b>Figure 1</b></p> <p style="text-align: center;"><b>STATUS INDICATION CRITERIA</b></p> <p>This status code is displayed when any failure of 1 REC to turn off during regen cycle.</p>	

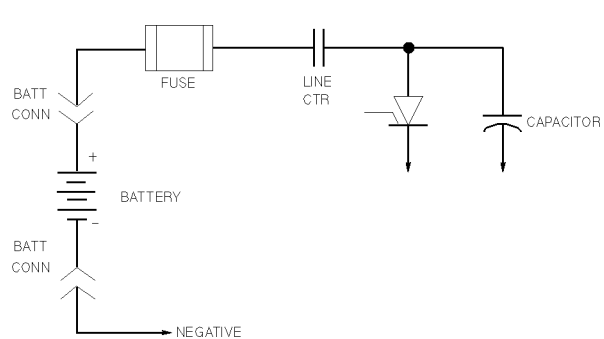
STATUS CODE <b>-76</b>	DESCRIPTION	MEMORY RECALL	Yes
	Capacitor overvoltage during Regen.		CONTROL TYPE
<p><b>SYMPTOM</b></p> <p>Forward or reverse contactor opens and closes, then opens and can only close by opening and closing the key switch</p> <p><b>POSSIBLE CAUSE</b></p> <p>Intermittent connection in battery power circuit.</p> <ul style="list-style-type: none"> <li>• Check battery power circuit, both positive and negative for loose connections.</li> <li>• Check power fuse, battery connectors, line contactors, and etc., for possible opening during regen cycle.</li> </ul> <p>Excessive source inductance.</p> <ul style="list-style-type: none"> <li>• Check for unfiltered tag lines.</li> <li>• Check for long battery cables.</li> </ul>		 <p>The diagram shows a battery circuit. On the left, there are two battery connectors labeled 'BATT CONN'. The positive terminal is connected to a fuse, followed by a line contactor (LINE CTR). After the contactor, the circuit splits: one path goes through a diode to ground, and the other path goes through a capacitor to ground. The negative terminal of the battery is also connected to a 'BATT CONN' and is labeled 'NEGATIVE'.</p>	
		<p><b>Figure 1</b></p> <p><b>STATUS INDICATION CRITERIA</b></p> <p>This status code is displayed when capacitor voltage is greater than 225 volts during the regen cycle.</p>	

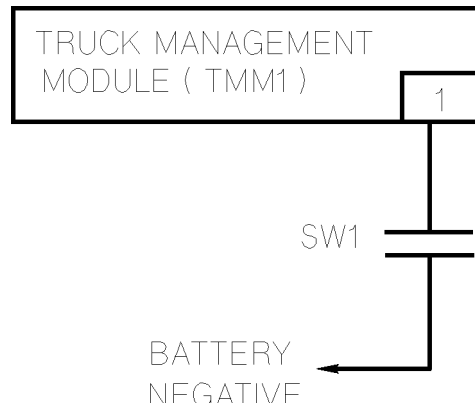
STATUS CODE <b>-90</b>	DESCRIPTION	MEMORY RECALL	No
	User defined status code - see OEM instructions manual.		CONTROL TYPE
<p><b>SYMPTOM</b></p> <p>Status code flashes on and off.</p> <p><b>POSSIBLE CAUSE</b></p> <p>User defined status code is displayed by switch closure or motor brush sensor closure to negative.</p> <ul style="list-style-type: none"> <li>• See OEM instruction manual for corrective action required.</li> </ul> <p>Other Causes:</p> <ul style="list-style-type: none"> <li>• Terminal 1 shorted to negative.</li> <li>• Defective input switch (shorted).</li> <li>• Defective TMM card.</li> </ul> <p>NOTE: When SCR pump control is used with internal TMM function, input terminal is PA3 on pump logic card.</p>		 <p>The diagram shows a 'TRUCK MANAGEMENT MODULE ( TMM1 )' with terminal '1' on the right. A switch labeled 'SW1' is connected between terminal 1 and the 'BATTERY NEGATIVE' terminal.</p>	
		<p><b>Figure 1</b></p> <p><b>STATUS INDICATION CRITERIA</b></p> <p>This status code is displayed when the voltage at terminal 1 of TMM is at zero volts.</p>	

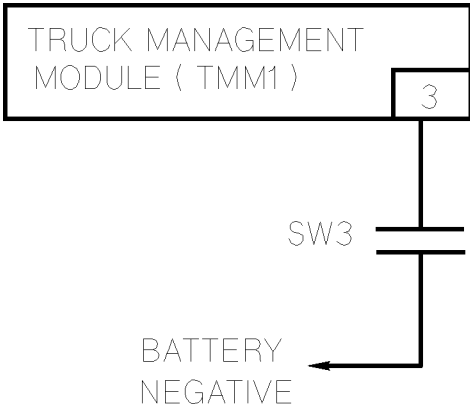

STATUS CODE <b>-91</b>	DESCRIPTION	MEMORY RECALL	No
	User defined status code - see OEM instructions manual.		CONTROL TYPE
<p><b>SYMPTOM</b> Status code flashes on and off.</p> <p><b>POSSIBLE CAUSE</b> User defined status code is displayed by switch closure or motor brush sensor closure to negative.</p> <ul style="list-style-type: none"> <li>See OEM instruction manual for corrective action required.</li> </ul> <p>Other Causes:</p> <ul style="list-style-type: none"> <li>Terminal 3 shorted to negative.</li> <li>Defective input switch (shorted).</li> <li>Defective TMM card.</li> </ul> <p>NOTE: When SCR pump control is used with internal TMM function, input terminal is PA6 on pump logic card.</p>		 <p style="text-align: center;">Figure 1</p>	
		STATUS INDICATION CRITERIA	
		This status code is displayed when the voltage at terminal 3 of TMM is at zero volts.	

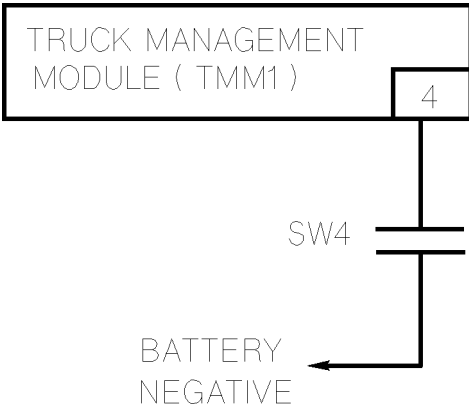
STATUS CODE <b>-92</b>	DESCRIPTION	MEMORY RECALL	No
	User defined status code - see OEM instructions manual.		CONTROL TYPE
<p><b>SYMPTOM</b> Status code flashes on and off.</p> <p><b>POSSIBLE CAUSE</b> User defined status code is displayed by switch closure or motor brush sensor closure to negative.</p> <ul style="list-style-type: none"> <li>See OEM instruction manual for corrective action required.</li> </ul> <p>Other Causes:</p> <ul style="list-style-type: none"> <li>Terminal 4 shorted to negative.</li> <li>Defective input switch (shorted).</li> <li>Defective TMM card.</li> </ul> <p>NOTE: When SCR pump control is used with internal TMM function, input terminal is PB6 on pump logic card.</p>		 <p style="text-align: center;">Figure 1</p>	
		STATUS INDICATION CRITERIA	
		This status code is displayed when the voltage at terminal 4 of TMM is at zero volts.	

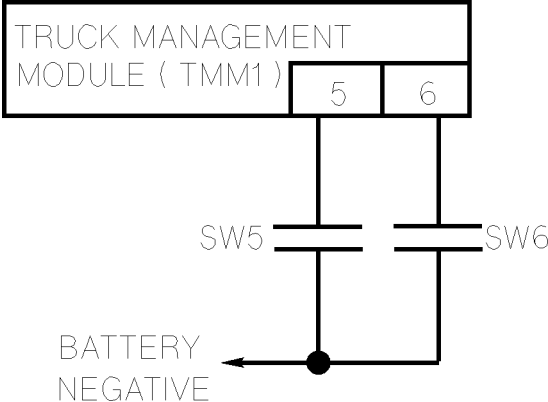
STATUS CODE <b>-93</b>	DESCRIPTION	MEMORY RECALL	No
	User defined status code - see OEM instructions manual.		CONTROL TYPE
<p><b>SYMPTOM</b> Status code flashes on and off.</p> <p><b>POSSIBLE CAUSE</b> User defined status code is displayed by switch closure or motor brush sensor closure to negative.</p> <ul style="list-style-type: none"> <li>See OEM instruction manual for corrective action required.</li> </ul> <p>Other Causes:</p> <ul style="list-style-type: none"> <li>Terminal 5 and 6 shorted to negative.</li> <li>Defective input switch (shorted).</li> <li>Defective TMM card.</li> </ul> <p>NOTE: When SCR pump control is used with internal TMM function, input terminal is PA1 and PA2 on pump logic card.</p>		 <p style="text-align: center;">Figure 1</p> <p><b>STATUS INDICATION CRITERIA</b> This status code is displayed when the voltage at terminal 5 and 6 of TMM is at zero volts.</p>	

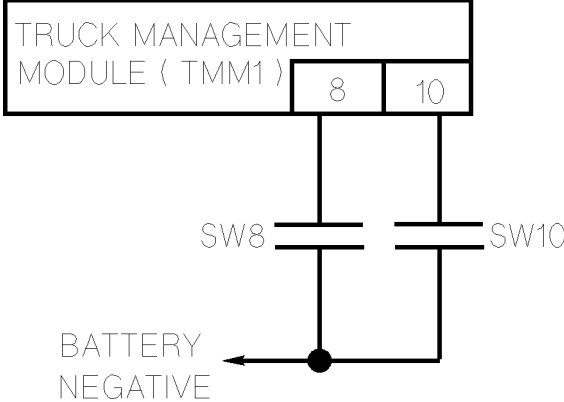
STATUS CODE <b>-94</b>	DESCRIPTION	MEMORY RECALL	No
	User defined status code - see OEM instructions manual.		CONTROL TYPE
<p><b>SYMPTOM</b> Status code flashes on and off.</p> <p><b>POSSIBLE CAUSE</b> User defined status code is displayed by switch closure or motor brush sensor closure to negative.</p> <ul style="list-style-type: none"> <li>See OEM instruction manual for corrective action required.</li> </ul> <p>Other Causes:</p> <ul style="list-style-type: none"> <li>Terminal 8 and 10 shorted to negative.</li> <li>Defective input switch (shorted).</li> <li>Defective TMM1 card.</li> </ul> <p>NOTE: When SCR pump control is used with internal TMM function, input terminal is PA4 and PA5 on pump logic card.</p>		 <p style="text-align: center;">Figure 1</p> <p><b>STATUS INDICATION CRITERIA</b> This status code is displayed when the voltage at terminal 8 and 10 of TMM is at zero volts.</p>	

STATUS CODE <b>-95</b>	DESCRIPTION	MEMORY RECALL	No
	User defined status code - see OEM instructions manual.		CONTROL TYPE
<p><b>SYMPTOM</b> Status code flashes on and off.</p> <p><b>POSSIBLE CAUSE</b> User defined status code is displayed by switch closure or motor brush sensor closure to negative.</p> <ul style="list-style-type: none"> <li>See OEM instruction manual for corrective action required.</li> </ul> <p>Other Causes:</p> <ul style="list-style-type: none"> <li>Terminal 11 and 12 shorted to negative.</li> <li>Defective input switch (shorted).</li> <li>Defective TMM card.</li> </ul> <p>NOTE: When SCR pump control is used with internal TMM function, input terminal is PB1 and PB2 on pump logic card.</p>		 <p>The diagram shows a rectangular box labeled 'TRUCK MANAGEMENT MODULE ( TMM1 )' with two terminals, '11' and '12'. Terminal 11 is connected to a switch labeled 'SW11', and terminal 12 is connected to a switch labeled 'SW12'. Both switches are connected to a common point that leads to a terminal labeled 'BATTERY NEGATIVE'.</p>	
		STATUS INDICATION CRITERIA	This status code is displayed when the voltage at terminal 11 and 12 of TMM is at zero volts.

Figure 1

STATUS CODE <b>-99</b>	DESCRIPTION	MEMORY RECALL	No
	Maintenance Alert Code		CONTROL TYPE
<p><b>SYMPTOM</b> Status code flashes on and off.</p> <p><b>POSSIBLE CAUSE</b> Maintenance Alert hours have been reached. Perform required maintenance and re-set maintenance alert hours, see Functions 19 and 20 in the Handset instructions.</p>		<p><b>NO DIAGRAM AVAILABLE FOR THIS STATUS CODE</b></p>	
		STATUS INDICATION CRITERIA	This status code is displayed the maintenance alert hours are reached.

Figure 1

<b>STATUS CODE</b> <b>-117</b>	<b>DESCRIPTION</b>	<b>MEMORY RECALL</b>	No
	Invalid card type selection.	<b>CONTROL TYPE</b>	Pump
<p><b>SYMPTOM</b> Pump contactor will not close.</p> <p><b>POSSIBLE CAUSE</b> Invalid card type selection.</p> <ul style="list-style-type: none"> <li>Review function 17 in the Handset Instruction sheets. Adjust and set card type value as instructed by OEM service manual.</li> </ul>		<p><b>NO DIAGRAM AVAILABLE FOR THIS STATUS CODE</b></p> <p>Figure 1</p> <p><b>STATUS INDICATION CRITERIA</b> This status code is displayed when the card type selection value is set to an invalid number.</p>	

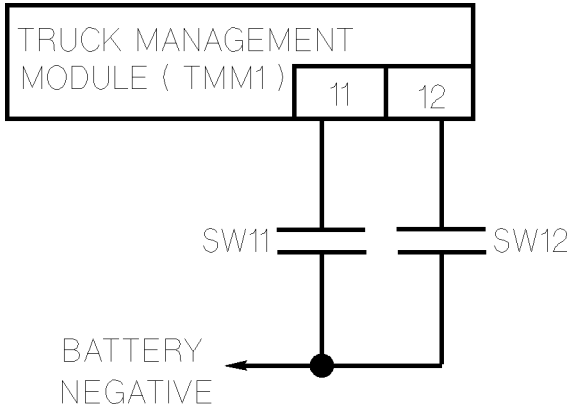
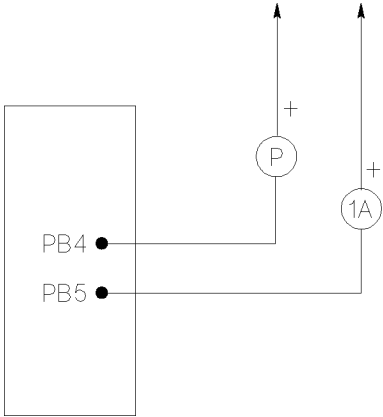
<b>STATUS CODE</b> <b>-123</b>	<b>DESCRIPTION</b>	<b>MEMORY RECALL</b>	No
	Forward and reverse contactor coil current low.	<b>CONTROL TYPE</b>	Pump
<p><b>SYMPTOM</b> Pump contactor will not pick up. Status code may alternate between code 23 and code 24. Complete check for code 23, if the problem is not found, perform check for code 24.</p> <p><b>POSSIBLE CAUSE</b> Defective Pump contactor coil circuit.</p> <ul style="list-style-type: none"> <li>Check for open circuit or loose connection between PB4 and positive side of Pump contactor coil.</li> <li>Remove plug A. Check ohmic value from PB4 to positive side of F coil. Value should be 10-14 ohms.</li> </ul> <p>Defective 1A contactor coil.</p> <ul style="list-style-type: none"> <li>Remove plug A. Check ohmic value from positive side of coil to its plug connection. Value should be 10-14 ohms.</li> </ul>		 <p>Figure 1</p> <p><b>STATUS INDICATION CRITERIA</b> This status code is displayed when the current draw in the pump contactor coil circuit is less than 100 ma.</p>	

STATUS CODE <b>-124</b>	DESCRIPTION	MEMORY RECALL	No
		T2 voltage low. (Greater than 12% battery volts.)	CONTROL TYPE
<p><b>SYMPTOM</b></p> <p>Control does not operate. Status code may alternate between code 23 and code 24. Complete checks for 24, if the problem is not found, perform code 23 check.</p> <p><b>POSSIBLE CAUSE</b></p> <p>Defective Pump contactor.</p> <ul style="list-style-type: none"> <li>Pump power tips fail to close because:           <ol style="list-style-type: none"> <li>1) Welded normally closed power tips.</li> <li>2) Binding contactor tip assembly.</li> <li>3) Defective Pump contactor coil. ( See status code 123)</li> </ol> </li> </ul> <p>Open motor circuit</p> <ul style="list-style-type: none"> <li>Check for open circuit or loose connection in motor circuit from the A1 connection to the A2 connection on the control panel.</li> </ul> <p>Defective 1A contactor.</p> <ul style="list-style-type: none"> <li>Perform checks as outlined in status 123.</li> </ul>		<p style="text-align: center;"><b>Figure 1</b></p> <p><b>STATUS INDICATION CRITERIA</b></p> <p>This status code is displayed when T2 volts is greater than 12% of battery volts and the pump driver is energized.</p>	

STATUS CODE <b>-125</b>	DESCRIPTION	MEMORY RECALL	No
		1A contactor does not drop out or drops out slowly.	CONTROL TYPE
<p><b>SYMPTOM</b></p> <p>Short tip life on Pump or 1A contactor. Status code 46 displayed and no fault found.</p> <p><b>POSSIBLE CAUSE</b></p> <p>Note: This status code can only be found by using the handset and looking at function 1. This status code is furnished as a troubleshooting aid for status code 146.</p> <p>Defective 1A contactor</p> <ul style="list-style-type: none"> <li>Check 1A contactor for binding or slow operation when dropping out.</li> </ul>		<p style="text-align: center;"><b>Figure 1</b></p> <p><b>STATUS INDICATION CRITERIA</b></p> <p>This status code is displayed when 1A contactor drop out time exceeds .060 seconds.</p>	

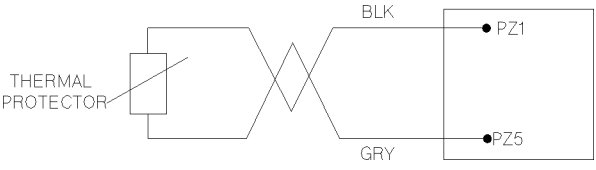
STATUS CODE <b>-141</b>	DESCRIPTION	MEMORY RECALL	No
		Open thermal protector (TP) or control over temperature.	CONTROL TYPE
<p><b>SYMPTOM</b> Reduced or no power to pump motor in SCR range.</p> <p><b>POSSIBLE CAUSE</b> Open thermal protector circuit.</p> <ul style="list-style-type: none"> <li>Check for loose connection or broken wire between: Black wire-Thermal proctor and PZ1. Gray wire-Thermal proctor and PZ5.</li> </ul> <p>Defective thermal protector.</p> <ul style="list-style-type: none"> <li>Disconnect wires from PZ1 and PZ5. At room temperature (25°C or 75°F) measure resistance between black and gray wire. Replace TP if ohmic value is greater than 300 ohms.</li> </ul> <p>SCR is in thermal cut-back.</p> <ul style="list-style-type: none"> <li>Allow control to cool, status code should disappear.</li> </ul>		 <p style="text-align: center;">Figure 1</p> <p><b>STATUS INDICATION CRITERIA</b> This status code is displayed when the voltage between PZ1 and PZ5 is greater than 1.8 volts.</p>	

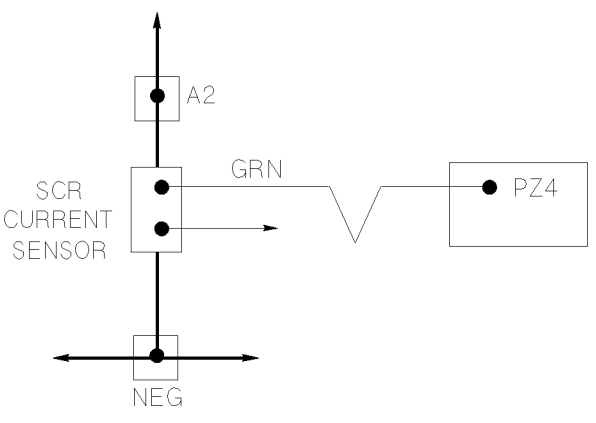
STATUS CODE <b>-142</b>	DESCRIPTION	MEMORY RECALL	No
		Control motor current sensor input missing.	CONTROL TYPE
<p><b>SYMPTOM</b> No power to pump motor in SCR range.</p> <p><b>POSSIBLE CAUSE</b> Open sensor wire circuit to PZ4.</p> <ul style="list-style-type: none"> <li>Check for loose connection or broken wire (green wire) from current sensor to PZ4 on the logic card.</li> </ul>		 <p style="text-align: center;">Figure 1</p> <p><b>STATUS INDICATION CRITERIA</b> This status code is displayed when voltage between PY7 and negative is greater than 1.6 volts with no current flowing in the motor circuit.</p>	

STATUS CODE <b>-143</b>	DESCRIPTION	MEMORY RECALL	No
		Control motor current sensor input missing.	CONTROL TYPE

<p><b>SYMPTOM</b></p> <p>Stall currents in SCR range higher than normal and uncontrollable with C/L adjustment.</p> <p><b>POSSIBLE CAUSE</b></p> <p>Open sensor wire circuit to PZ3.</p> <ul style="list-style-type: none"> <li>• Check for loose connections or broken wire (yellow wire) from current sensor to PZ3 on logic card.</li> </ul>	 <p style="text-align: center;"><b>Figure 1</b></p> <p><b>STATUS INDICATION CRITERIA</b></p> <p>This status code is displayed when voltage between PY7 and negative is less than .84 volts with no current flowing in motor circuit.</p>
---	--

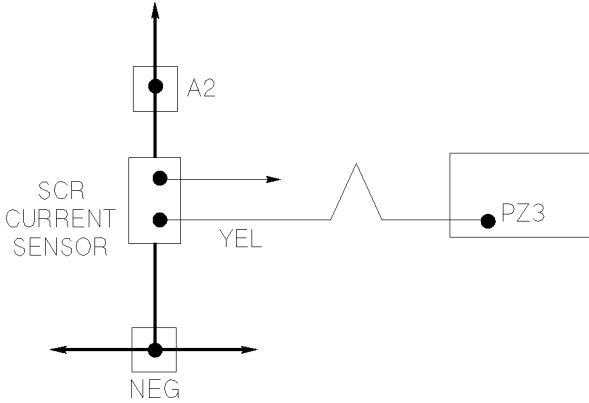
STATUS CODE <b>-144</b>	DESCRIPTION	MEMORY RECALL	Yes
		1REC did not turn off properly.	CONTROL TYPE

<p><b>SYMPTOM</b></p> <p>Forward or reverse contactors open and close, then can only be closed by opening and closing the key switch.</p> <p><b>POSSIBLE CAUSE</b></p> <p>Defective 5 REC circuit.</p> <ul style="list-style-type: none"> <li>• Check for shorted 5 REC.</li> <li>• Check for shorted 5 REC snubber (25 REC).</li> </ul> <p>Defective 2 REC circuit.</p> <ul style="list-style-type: none"> <li>• Check for shorted 2 REC.</li> <li>• Check for shorted 2 REC snubber (22 REC).</li> </ul> <p>Open choke (1X).</p> <ul style="list-style-type: none"> <li>• Check for open circuit between T5 and T3. Ohm meter should read zero ohms.</li> </ul> <p>1 REC defective.</p> <ul style="list-style-type: none"> <li>• Turn off time for 1 REC out of specification. No field test is possible. Replace 1 REC after above checks, show no problem found.</li> </ul>	 <p style="text-align: center;"><b>Figure 1</b></p> <p><b>STATUS INDICATION CRITERIA</b></p> <p>This status code is displayed when, during SCR operation, 1 REC fails to turn off.</p>
---	--

STATUS CODE <b>-145</b>	DESCRIPTION	MEMORY RECALL	Yes
		1 REC did not turn on properly.	CONTROL TYPE
<p><b>SYMPTOM</b> Forward or reverse contactor will open and close, then open and then can only be closed by opening and closing the key switch.</p> <p><b>POSSIBLE CAUSE</b> Defective 2 REC circuit.  <ul style="list-style-type: none"> <li>• Check for shorted 2 REC.</li> <li>• Check for shorted 2 REC snubber (22 REC).</li> </ul> Defective 1 REC circuit.  <ul style="list-style-type: none"> <li>• Check for open circuit or loose connections between 1REC and PZ8. (white/blue wire)</li> <li>• Check for open circuit or loose connection between 1REC (3 REC snubber) and PZ9. (blue wire)</li> </ul> Defective 1 REC.  <ul style="list-style-type: none"> <li>• Intermittent or open 1 REC gate. Field test may or may not show defect. Replace 1 REC after above checks, show no problem found.</li> </ul> </p>		<p style="text-align: center;"><b>Figure 1</b></p>	
		STATUS INDICATION CRITERIA	This status code is displayed when 1 REC fails to gate on.

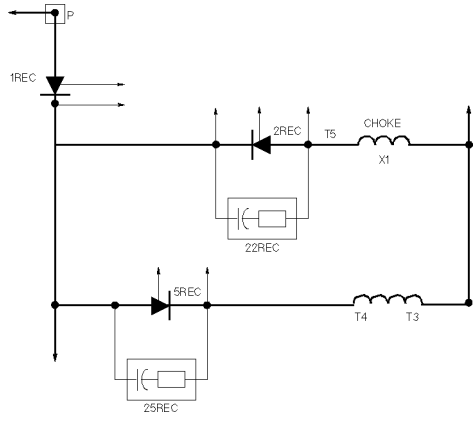
STATUS CODE <b>-146</b>	DESCRIPTION	MEMORY RECALL	No
		Look ahead test for T2 volts. ( Greater than 85% of battery volts)	CONTROL TYPE
<p><b>SYMPTOM</b> Pump contactor will not pick up.</p> <p><b>POSSIBLE CAUSE</b> Defective 1 REC.  <ul style="list-style-type: none"> <li>• Check for shorted 1 REC.</li> <li>• Check for defective 1 REC insulator (co-therm) that may short 1 REC heat sink to base plate.</li> </ul> Defective 1A contactor.  <ul style="list-style-type: none"> <li>• Check for welded 1A contactor power tips.</li> </ul> </p>		<p style="text-align: center;"><b>Figure 1</b></p>	
		STATUS INDICATION CRITERIA	This status code is displayed when the voltage at T2 is greater than 85% of battery volts.



<b>STATUS CODE</b> <b>-147</b>	<b>DESCRIPTION</b>	<b>MEMORY RECALL</b>	No
	2REC does not turn properly	<b>CONTROL TYPE</b>	Pump

**SYMPTOM**  
Pump contactor will open and close, then open and then can only be closed by opening and closing the key switch.

- POSSIBLE CAUSE**
- Defective 2 REC circuit.
- Check that 2 REC will gate on.
  - Check for open circuit or loose connection between 2 REC gate and PZ10. (white/red wire)
  - Check for open circuit or loose connection 1 REC and 1C through the 2 REC circuit.
- F or R contactor or power tips bouncing open.
- Check that power tips on F and R contactor power tips do not bounce open during operation (ie: travel over speed bumps or dock plates).

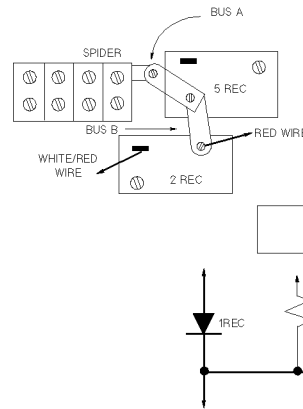

Figure 1

**STATUS INDICATION CRITERIA**  
This status code is displayed when the 2 REC fails to turn on.

<b>STATUS CODE</b> <b>-148</b>	<b>DESCRIPTION</b>	<b>MEMORY RECALL</b>	No
	Look ahead test for T2 volts. (Less than 12% of battery volts)	<b>CONTROL TYPE</b>	Pump

**SYMPTOM**  
Pump contactor will not pick up.

- POSSIBLE CAUSE**
- Defective forward or reverse contactor.
- Check for welded forward or reverse contactor power tips.
  - Check for sluggish operation of forward or reverse contactor.
- Defective 3 REC circuit.
- Check for shorted 3 REC.
  - Check for shorted 3 REC snubber (23 REC).

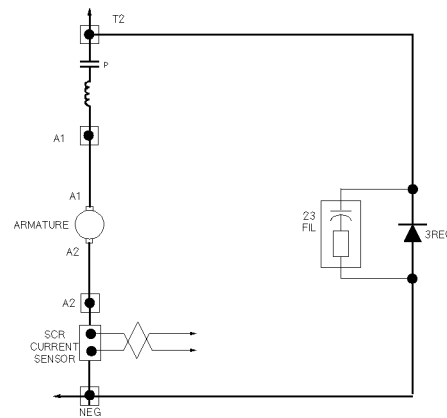

Figure 1

**STATUS INDICATION CRITERIA**  
This status code is displayed when the voltage at T2 is less than 12% of battery volts.

STATUS CODE <b>-149</b>	DESCRIPTION	MEMORY RECALL	No
		5 REC does not turn on properly	CONTROL TYPE
<p><b>SYMPTOM</b> Pump contactor will open and close, then open and then can only be closed by opening and closing the key switch.</p> <p><b>POSSIBLE CAUSE</b></p> <p>Defective 5 REC circuit</p> <ul style="list-style-type: none"> <li>• Check for shorted 5 REC.</li> <li>• Check for shorted 5 REC snubber ( 25 REC ).</li> <li>• Check that 5 REC will gate on.</li> <li>• Check for open circuit or loose connection between 5 REC gate and PZ12 ( white/violet wire ).</li> </ul> <p>Shorted 2 REC circuit.</p> <ul style="list-style-type: none"> <li>• Check 2 REC and 2 REC snubber ( 22 REC ) for short circuit.</li> </ul> <p>Defective capacitor circuit.</p> <ul style="list-style-type: none"> <li>• Check for open capacitor.</li> <li>• Check for loose connections at capacitor terminals.</li> </ul>		<p style="text-align: center;"><b>Figure 1</b></p> <p style="text-align: center;"><b>STATUS INDICATION CRITERIA</b> This status code is displayed when the 5 REC circuit fails to turn on.</p>	

STATUS CODE <b>-150</b>	DESCRIPTION	MEMORY RECALL	No
		Capacitor volts low .	CONTROL TYPE
<p><b>SYMPTOM</b> Pump contactor picks up. Control does not operate.</p> <p><b>POSSIBLE CAUSE</b></p> <p>Defective 2 REC circuit.</p> <ul style="list-style-type: none"> <li>• Open circuit or loose connection between spider assembly and 5 REC (BUS A).</li> <li>• Open circuit or loose connection between 5 REC and 2 REC.</li> <li>• Open circuit or loose connection between 2 REC and PZ11 (red wire) and between 2 REC gate and PZ10 (white/red wire).</li> <li>• Check 2 REC to insure that it will gate on.</li> </ul>		<p style="text-align: center;"><b>Figure 1</b></p> <p style="text-align: center;"><b>STATUS INDICATION CRITERIA</b> This status code is displayed when 2 REC circuit fails to turn on at initial start up.</p>	

STATUS CODE <b>-151</b>	DESCRIPTION	MEMORY RECALL	No
	Excessive capacitor voltage when motor current is high.		CONTROL TYPE

<p><b>SYMPTOM</b> Pump contactors open and close, then can only be closed by opening and closing the key switch.</p> <p><b>POSSIBLE CAUSE</b> Excessive source inductance.</p> <ul style="list-style-type: none"> <li>• Tag lines without filters are being used.</li> <li>• Battery cables are too long.</li> </ul> <p>High peak current in motor.</p> <ul style="list-style-type: none"> <li>• Check for shorted field winding.</li> <li>• Check for shorted armature winding.</li> </ul>	<p style="text-align: center;"><b>Figure 1</b></p> <p><b>STATUS INDICATION CRITERIA</b> This status code is displayed when capacitor volts exceed 225 volts and motor current is greater than 300 amps.</p>
---	---

STATUS CODE <b>-152</b>	DESCRIPTION	MEMORY RECALL	Yes
	Excessive capacitor voltage when motor current is low.		CONTROL TYPE

<p><b>SYMPTOM</b> Pump contactors open and close, then can only be closed by opening and closing the key switch.</p> <p><b>POSSIBLE CAUSE</b> Excessive source inductance.</p> <ul style="list-style-type: none"> <li>• Tag lines without filters are being used.</li> <li>• Battery cables are too long.</li> </ul> <p>Defective 4 REC circuit.</p> <ul style="list-style-type: none"> <li>• Check for shorted 4 REC.</li> <li>• Check for open circuit or loose connection in 4 REC circuit.</li> </ul> <p>Defective 3 REC circuit.</p> <ul style="list-style-type: none"> <li>• Check for open circuit or loose connection in 3 REC circuit.</li> </ul>	<p style="text-align: center;"><b>Figure 1</b></p> <p><b>STATUS INDICATION CRITERIA</b> This status code is displayed when capacitor volts exceed 225 volts and motor current is less than 200 amps.</p>
--	--

<b>STATUS CODE</b> <b>-154</b>	<b>DESCRIPTION</b>	<b>MEMORY RECALL</b>	No
	Shorted Pump or 1A contactor coil driver.	<b>CONTROL TYPE</b>	Pump
<p><b>SYMPTOM</b></p> <p>Control will not operate.</p> <p><b>POSSIBLE CAUSE</b></p> <p>Defective logic card.</p> <ul style="list-style-type: none"> <li>• Replace logic card.</li> </ul>		<p align="center"><b>Figure 1</b></p>	
		<p align="center"><b>STATUS INDICATION CRITERIA</b></p> <p>This status code is displayed when either the Pump or 1A contactor coil driver is shorted internal to the logic card.</p>	

<b>STATUS CODE</b> <b>-157</b>	<b>DESCRIPTION</b>	<b>MEMORY RECALL</b>	No
	Current sensor input voltage polarity check.	<b>CONTROL TYPE</b>	Pump
<p><b>SYMPTOM</b></p> <p>Pump contactors open and close, then can only be closed by opening and closing the key switch.</p> <p><b>POSSIBLE CAUSE</b></p> <p>Reversed yellow and green current sensors wires</p> <ul style="list-style-type: none"> <li>• Insure that the: -green wire connects to PZ4 with no open circuits.</li> <li>-yellow wire connects to PZ3 with no open circuits or loose connections.</li> </ul> <p>Reversed power cable connection.</p> <ul style="list-style-type: none"> <li>• Insure that the battery negative cable connects to SCR NEG and the motor A2 cable connects to SCR A2.</li> </ul>		 <p align="center"><b>Figure 1</b></p>	
		<p align="center"><b>STATUS INDICATION CRITERIA</b></p> <p>This status code is displayed when the voltage input to PZ4 and PZ3 is the wrong polarity.</p>	

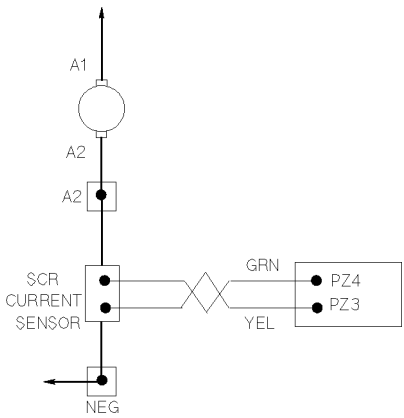
## TABLE 4 CHECKING COMPONENTS

### Main Logic Card

All trouble-shooting is written to check all outside devices and eliminate them as the source of the symptoms. The conclusion being then that the card is faulty.

#### 1. Instructions for Removal of Control Card.

Remove control wires on the screw terminals 1 through 6 as required.

Unplug A, B, and Z plugs by pressing down on tab with wide blade screwdriver and rotating 90 degrees.

Remove the two mounting screws and lift card box free.

NOTE: Do not attempt to remove circuit board from card box.

Reverse procedures to install new control card.

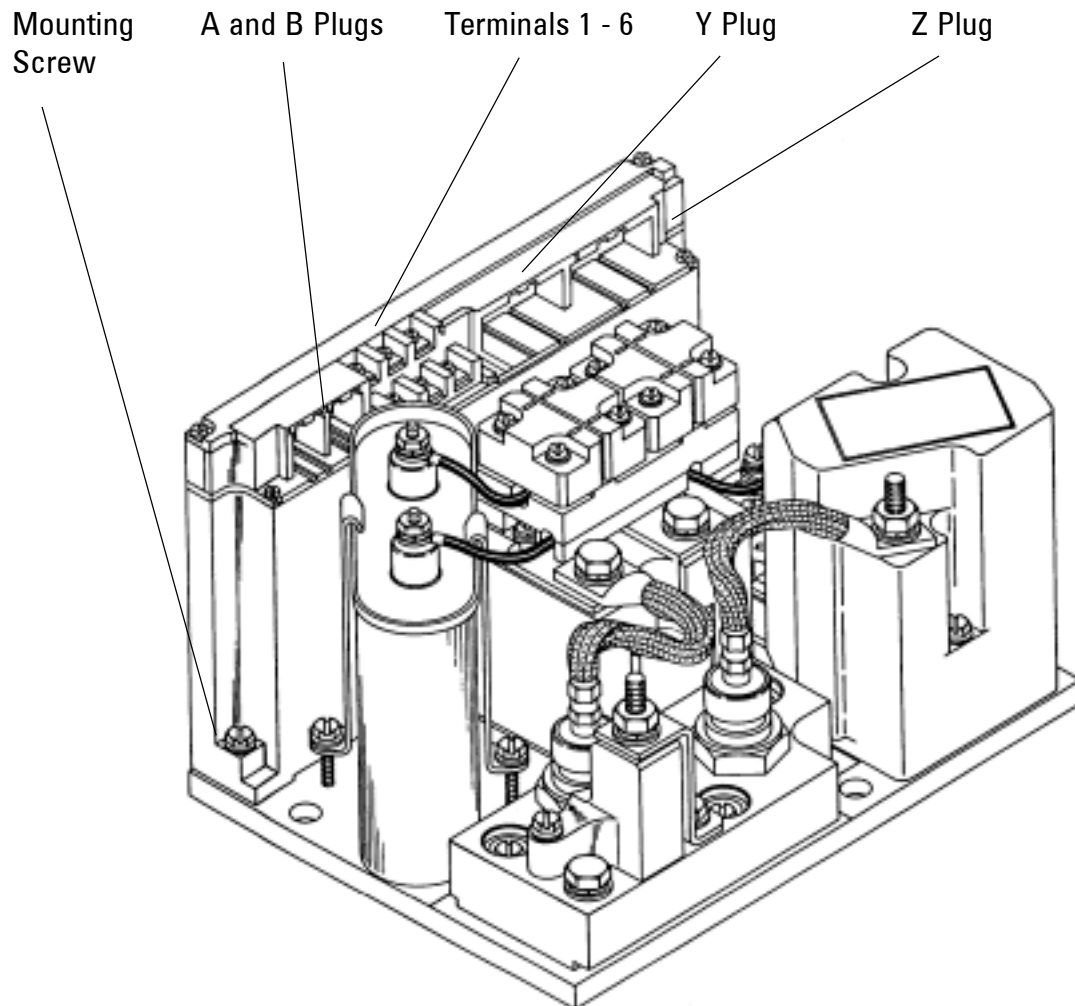

## Capacitor 1C

Disconnect the battery and discharge the capacitor. Measure ohms through the capacitor using the R x 10,000 scale. Meter should read zero and then swing slowly to above 100,000 ohms. Replace the capacitor if above reading is not obtained.

Contactors F, R, 1A, SP, FW, D, REGEN and P

150 ampere contactors instruction sheets.

300 ampere contactors instruction sheets.

### NOTE:

Control is arranged so that the F and R contactors do not break current. Check to see that the 1A contactor drops out before the F or R contactor.

Most contactor coils are polarity sensitive. The left-hand terminal must be connected to positive.

## Potentiometer in Accelerator

To check operation of the potentiometer, disconnect the battery and disconnect the wire at control card TB1. Connect a VOM to the wire that was removed from TB1 and to negative. Place the VOM on the R x 100 scale. With the accelerator in the creep speed position, the ohms reading should be 4800 to 6000 ohms. With the accelerator in the top speed position, the ohm reading should be 50 ohms or less. With the wire disconnected as above, check for resistance of 1 megohm or higher from pot wire to the truck frame.

## SCR's (1REC, 2REC, 5REC)

These are silicon controlled rectifiers. Before checking, disconnect the battery and discharge capacitor 1C. Disconnect gate leads of SCR's at the SCR terminal.

To check an SCR, it is necessary to have a 6 volt battery and 2 A-14 diodes.

Connect the positive lead to the anode, connect the negative lead to the cathode as shown below.

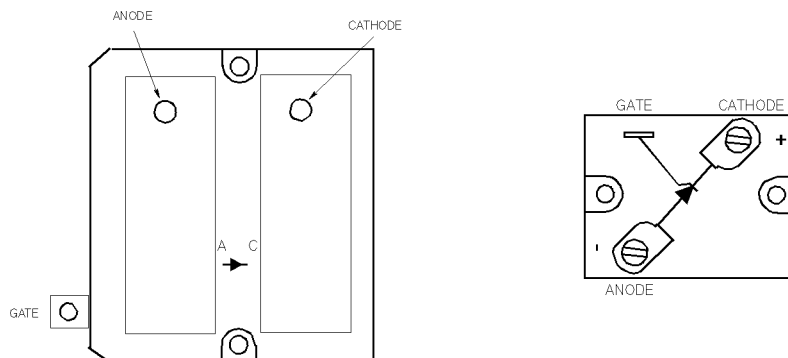

(1). The lamp should not light. If the lamp does light, the SCR is shorted and must be replaced.

(2). If check (1) was satisfactory, test the SCR for its ability to be turned on by the gate. Connect positive through two diodes to the gate terminal. If the gate is operative, the lamp will come on and remain on when the gate is removed. Some SCR's will operate correctly even if the lamp does not remain on, particularly with a weak battery.

(3). If the lamp cannot be lit under step (2) the SCR is open and must be replaced.

#### NOTE:

If you do not have a test light to check the SCR's as described above, they may be checked for shorts and opens by use of the VOM.

Measure resistance from anode to cathode (R x 100 scale). If SCR is shorted (zero ohms), it must be replaced.

Measure resistance from the gate terminal to the cathode and then from the cathode to the gate terminal (R x100 scale). If resistance reads either zero ohms (short) or infinity ohms (open), replace the SCR. When reassembling SCR's, refer to TABLE 5.

#### Rectifiers (3REC, 4REC, Diode Blocks)

When checking diodes, disconnect battery and discharge capacitor 1C. When replacing rectifiers, refer to TABLE 5. For 3REC and 4REC, disconnect one lead or flexible connection.

3REC and 4REC are diode with about 7 to 12 ohms in the conducting direction (anode to cathode) measure on the R x 100 scale, and 10,000 ohms or higher, in the non-conducting direction (cathode to anode) measured on the R x 10,000 scale.

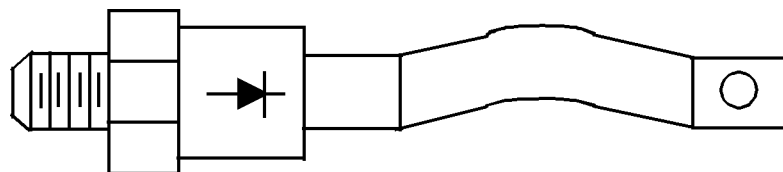

#### Thermal Protector (TP)

Remove both the GRAY and BLACK wires from the "Z" plug that connects to the control card. Read the resistance between these two wires with the VOM set on the R x 100 scale. VOM should read 100 to 200 ohms if the 1REC heatsink is at room temperature (25C or 75F). Set the VOM to the highest ohm scale and read from each wires end to the 1REC heatsink, reading should be infinity.

### Filter Block(23FIL,etc.)

To check, disconnect all wires from the filter block on remove from panel. With VOM on the R x 10,000, touch the leads to the filter terminals to charge the filter. After a few seconds, reverse the meter leads and touch the filter terminal. The VOM needle will deflect and return to infinity. If this capacitor action is not observed, replace the filter block.

### Filter Block(23FIL,etc.)

Filter block test 4K is only to detect an open or shorted filter. If the control has symptoms as in 1E, interchange 22REC and 25REC and try again. If the problem is corrected, the old 25REC is marginal and should be replaced. If the problem is not corrected, replace both filters.

### 1X Choke and Reactor T3-T4

Refer to panel wiring diagram to locate windings. With VOM on R x 1 scale, measure choke or reactor winding, reading should be less than 1 ohm.



## REPLACEMENT OF EV-100 COMPONENTS

When replacing stud semiconductors such as 3REC and 4REC it is not necessary to torque these devices to a specific value.

The use of a heat-transfer grease (such as GE Versilube G-350-M or equivalent) is recommended.

When replacing module semiconductors such as 1REC, 2REC or 5REC

Remove all module connections. (As required)

Remove module by backing out the two screws at the device sides.

Clean the insulator surface with a clean rag and isopropyl alcohol.

Inspect the insulator surface for tears or cracks. If defective, replace. Wipe a light layer of machine oil on the base and smooth the insulator into position.

NOTE: Insulator not required for 2REC and 5REC.

Coat insulator with a light coat of heat-transfer grease similar to GE-350.

Set new module on insulator and start screws back into base. Be sure to use the original screws and washers. run screws in to base "finger tight".

Check that the bottom of the module is flat against the insulator or base.

Alternately tighten the two screws by 1/4 turn until firm.

Replace all connections removed in step 1.

### Capacitor

Remove nuts from capacitor connections and remove wires.

Remove hold down brackets and lift out.

Reverse procedure to replace capacitor.

### 22REC, 23REC and 25REC

Remove mounting screws and lift out.

NOTE: When replacing these devices, use the original hardware in the same holes, as the inserts are used for electrical connections.

## Reactor/Choke

Disconnect all leads to the reactor.

Remove the two mounting bolts and lift out.

Set new reactor on SCR base and start screws back into base. Be sure to use the original screws and washers. run screws in to base "finger tight".

Check that the bottom of the reactor is flat against the base.

Alternately tighten the two screws by 1/4 turn until firm.

Replace all connections removed in step 1.

## Appendix A : MEMORY MAP FOR IC3645LXCD1ZT, ZX, ZH AND ZY

E <sup>2</sup> No.	Func No.	HS No.	Function	Access By:	Restrictions
0	1	1	Fault Code	HS or PC	Erases when battery is unplugged
1	2	2	Creep	HS or PC	None
2	3	3	Controlled Acceleration	HS or PC	None
3	4	4	Current Limit	HS or PC	None
4	5	5	Plug Current Limit	HS or PC	None
5	6	6	1A Dropout	HS or PC	None
6	7	7	FW Pickup	HS or PC	None
7	8	8	FW Dropout	HS or PC	None
8	9	9	Regen Current Limit	HS or PC	None
9	10	10	Regen Start	HS or PC	None
10	11	11	Speed Limit 1	HS or PC	None
11	12	12	Speed Limit 2	HS or PC	None
12	13	13	Speed Limit 3	HS or PC	None
13	14	14	IR Compensation	HS or PC	None
14	15	15	Battery Volts Select	HS or PC	None
15	16	16	Pedal Position Plug	HS or PC	None
16	17	17	Card type Select	HS or PC	None
17	18	18	Steer Pump Time Delay	HS or PC	None
18	19	19	Maint Alert (Tens/Units)	HS or PC	None
19	20	20	Maint Alert (Thou/Hund)	HS or PC	None
20	21	21	Maint Speed Limit	HS or PC	None
21	22	22	Mode Reference	HS or PC	Reference for Dash Display on battery power up
22	23	23	Hourmeter (Min)	HS or PC	None
23	24	24	Hourmeter (Sec)	HS or PC	None
24	25	25	Fault Reg Data	HS or PC	GE Tempory Storgage
25	26	26	Battery Charge Data	HS or PC	GE Tempory Storgage
26	27	27	Battery Volts Data	HS or PC	GE Tempory Storgage
27	28	28	Fault Count Pointer	HS or PC	None ( Location of last fault recorded )
28	29	29	HM(Tens/Units)	HS or PC	None
29	30	30	HM(Thou/Hund)	HS or PC	None
30	31		Aux HM (Tens/Units)	PC Only	None
31	32		Aux HM (Thou/Hund)	PC Only	None
32	33	<b>(18)</b>	Fault 1	PC Only	Reset to Zero Only
33	34		BDI 1	PC Only	Reset to Zero Only
34	35		Hours (Tens/Units) 1	PC Only	Reset to Zero Only
35	36		Hours (Thou/Hunds) 1	PC Only	Reset to Zero Only
36	37	<b>(20)</b>	Fault 2	PC Only	Reset to Zero Only
37	38		BDI 2	PC Only	Reset to Zero Only
38	39		Hours (Tens/Units) 2	PC Only	Reset to Zero Only
39	40		Hours (Thou/Hunds) 2	PC Only	Reset to Zero Only
40	41	<b>(22)</b>	Fault 3	PC Only	Reset to Zero Only
41	42		BDI 3	PC Only	Reset to Zero Only
42	43		Hours (Tens/Units) 3	PC Only	Reset to Zero Only
43	44		Hours (Thou/Hunds) 3	PC Only	Reset to Zero Only
44	45	<b>(24)</b>	Fault 4	PC Only	Reset to Zero Only
45	46		BDI 4	PC Only	Reset to Zero Only
46	47		Hours (Tens/Units) 4	PC Only	Reset to Zero Only
47	48		Hours (Thou/Hunds) 4	PC Only	Reset to Zero Only
48	49	<b>(26)</b>	Fault 5	PC Only	Reset to Zero Only
49	50		BDI 5	PC Only	Reset to Zero Only

Numbers in ( **bold italic** ) are stored fault pointers

<b>E<sup>2</sup> No.</b>	<b>Func No.</b>	<b>HS No.</b>	<b>Function</b>	<b>Access By:</b>	<b>Restrictions</b>
50	51		Hours (Tens/Units) 5	PC Only	Reset to Zero Only
51	52		Hours (Thou/Hunds) 5	PC Only	Reset to Zero Only
52	53	<b>(28)</b>	Fault 6	PC Only	Reset to Zero Only
53	54		BDI 6	PC Only	Reset to Zero Only
54	55		Hours (Tens/Units) 6	PC Only	Reset to Zero Only
55	56		Hours (Thou/Hunds) 6	PC Only	Reset to Zero Only
56	57	<b>(30)</b>	Fault 7	PC Only	Reset to Zero Only
57	58		BDI 7	PC Only	Reset to Zero Only
58	59		Hours (Tens/Units) 7	PC Only	Reset to Zero Only
59	60		Hours (Thou/Hunds) 7	PC Only	Reset to Zero Only
60	61	<b>(32)</b>	Fault 8	PC Only	Reset to Zero Only
61	62		BDI 8	PC Only	Reset to Zero Only
62	63		Hours (Tens/Units) 8	PC Only	Reset to Zero Only
63	64		Hours (Thou/Hunds) 8	PC Only	Reset to Zero Only
64	65	<b>(34)</b>	Fault 9	PC Only	Reset to Zero Only
65	66		BDI 9	PC Only	Reset to Zero Only
66	67		Hours (Tens/Units) 9	PC Only	Reset to Zero Only
67	68		Hours (Thou/Hunds) 9	PC Only	Reset to Zero Only
68	69	<b>(36)</b>	Fault 10	PC Only	Reset to Zero Only
69	70		BDI 10	PC Only	Reset to Zero Only
70	71		Hours (Tens/Units) 10	PC Only	Reset to Zero Only
71	72		Hours (Thou/Hunds) 10	PC Only	Reset to Zero Only
72	73	<b>(38)</b>	Fault 11	PC Only	Reset to Zero Only
73	74		BDI 11	PC Only	Reset to Zero Only
74	75		Hours (Tens/Units) 11	PC Only	Reset to Zero Only
75	76		Hours (Thou/Hunds) 11	PC Only	Reset to Zero Only
76	77	<b>(40)</b>	Fault 12	PC Only	Reset to Zero Only
77	78		BDI 12	PC Only	Reset to Zero Only
78	79		Hours (Tens/Units) 12	PC Only	Reset to Zero Only
79	80		Hours (Thou/Hunds) 12	PC Only	Reset to Zero Only
80	81	<b>(42)</b>	Fault 13	PC Only	Reset to Zero Only
81	82		BDI 13	PC Only	Reset to Zero Only
82	83		Hours (Tens/Units) 13	PC Only	Reset to Zero Only
83	84		Hours (Thou/Hunds) 13	PC Only	Reset to Zero Only
84	85	<b>(44)</b>	Fault 14	PC Only	Reset to Zero Only
85	86		BDI 14	PC Only	Reset to Zero Only
86	87		Hours (Tens/Units) 14	PC Only	Reset to Zero Only
87	88		Hours (Thou/Hunds) 14	PC Only	Reset to Zero Only
88	89	<b>(46)</b>	Fault 15	PC Only	Reset to Zero Only
89	90		BDI 15	PC Only	Reset to Zero Only
90	91		Hours (Tens/Units) 15	PC Only	Reset to Zero Only
91	92		Hours (Thou/Hunds) 15	PC Only	Reset to Zero Only
92	93	<b>(48)</b>	Fault 16	PC Only	Reset to Zero Only
93	94		BDI 16	PC Only	Reset to Zero Only
94	95		Hours (Tens/Units) 16	PC Only	Reset to Zero Only
95	96		Hours (Thou/Hunds) 16	PC Only	Reset to Zero Only
96	97	48	Dash Display CA-1	HS or PC	None
97	98	49	Dash Display FWPU-1	HS or PC	None
98	99	50	Dash Display SL1-1	HS or PC	None
99	100	51	Spare-1	HS or PC	None

<b>E<sup>2</sup> No.</b>	<b>Func No.</b>	<b>HS No.</b>	<b>Function</b>	<b>Access By:</b>	<b>Restrictions</b>
100	101	52	Dash Display CA-2	HS or PC	None
101	102	53	Dash Display FWPU-2	HS or PC	None
102	103	54	Dash Display SL1-2	HS or PC	None
103	104	55	Spare-2	HS or PC	None
104	105	56	Dash Display CA-3	HS or PC	None
105	106	57	Dash Display FWPU-3	HS or PC	None
106	107	58	Dash Display SL1-3	HS or PC	None
107	108	59	Spare-3	HS or PC	None
108	109	60	Dash Display CA-4	HS or PC	None
109	110	61	Dash Display FWPU-4	HS or PC	None
110	111	62	Dash Display SL1-4	HS or PC	None
111	112		Spare-4	PC Only	None
112	113		Secure HM (Tens/Units)	PC Only	OEM Read Only
113	114		Secure HM (Thou/Hund)	PC Only	OEM Read Only
114	115		Sec Aux HM (Tens/Units)	PC Only	OEM Read Only
115	116		Sec Aux HM (Thou/Hund)	PC Only	OEM Read Only
116	117		Reserved	PC Only	GE Future Use Only
117	118		Reserved	PC Only	GE Future Use Only
118	119		Reserved	PC Only	GE Future Use Only
119	120		Reserved	PC Only	GE Future Use Only
120	121		OEM Use	PC Only	None
121	122		OEM Use	PC Only	None
122	123		OEM Use	PC Only	None
123	124		OEM Use	PC Only	None
124	125		OEM Use	PC Only	None
125	126		OEM Use	PC Only	None
126	127		OEM Use	PC Only	None
127	128		OEM Use	PC Only	None

## Appendix B : MEMORY MAP FOR IC3645LXCD1ZP

E <sup>2</sup> No.	Func No.	HS No.	Function	Access By:	Restrictions
0	1	1	Fault Code	HS or PC	Erases when battery is unplugged
1	2	2	IR Start	HS or PC	None
2	3	3	C/A	HS or PC	None
3	4	4	C/L	HS or PC	None
4	5	5	Spare		
5	6	6	Spare		
6	7	7	IR Comp Rate	HS or PC	None
7	8	8	Spare		
8	9	9	Spare		
9	10	10	Spare		
10	11	11	Speed Limit (SL1)	HS or PC	None
11	12	12	Speed Limit (SL2)	HS or PC	None
12	13	13	Speed Limit (SL3)	HS or PC	None
13	14	14	Speed Limit (SL4)	HS or PC	None
14	15	15			
15	16	16	Speed/Torque Compensation	HS or PC	None
16	17	17	Card type Select	HS or PC	None
17	18	18	Spare		
18	19	19	Spare		
19	20	20	Spare		
20	21	21	Spare		
21	22	22	Mode Reference	HS or PC	Reference for Dash Display on battery power up
22	23	23	Hourmeter (Min)	HS or PC	None
23	24	24	Hourmeter (Sec)	HS or PC	None
24	25	25	Fault Reg Data	HS or PC	GE Temporary Storage
25	26	26	Spare		
26	27	27	Spare		
27	28	28	Fault Count Pointer	HS or PC	None ( Location of last fault recorded )
28	29	29	HM(Tens/Units)	HS or PC	None
29	30	30	HM(Thou/Hund)	HS or PC	None
30	31		AuxHM (Tens/Units)	PC Only	None
31	32		AuxHM (Thou/Hund)	PC Only	None
32	33	<b>(18)</b>	Fault 1	PC Only	Reset to Zero Only
33	34		Spare		
34	35		Hours (Tens/Units) 1	PC Only	Reset to Zero Only
35	36		Hours (Thou/Hunds) 1	PC Only	Reset to Zero Only
36	37	<b>(20)</b>	Fault 2	PC Only	Reset to Zero Only
37	38		Spare		
38	39		Hours (Tens/Units) 2	PC Only	Reset to Zero Only
39	40		Hours (Thou/Hunds) 2	PC Only	Reset to Zero Only
40	41	<b>(22)</b>	Fault 3	PC Only	Reset to Zero Only
41	42		Spare		
42	43		Hours (Tens/Units) 3	PC Only	Reset to Zero Only
43	44		Hours (Thou/Hunds) 3	PC Only	Reset to Zero Only
44	45	<b>(24)</b>	Fault 4	PC Only	Reset to Zero Only
45	46		Spare		
46	47		Hours (Tens/Units) 4	PC Only	Reset to Zero Only
47	48		Hours (Thou/Hunds) 4	PC Only	Reset to Zero Only
48	49	<b>(26)</b>	Fault 5	PC Only	Reset to Zero Only
49	50		Spare		

<b>E<sup>2</sup> No.</b>	<b>Func No.</b>	<b>HS No.</b>	<b>Function</b>	<b>Access By:</b>	<b>Restrictions</b>
50	51		Hours (Tens/Units) 5	PC Only	Reset to Zero Only
51	52		Hours (Thou/Hunds) 5	PC Only	Reset to Zero Only
52	53	<b>(28)</b>	Fault 6	PC Only	Reset to Zero Only
53	54		Spare		
54	55		Hours (Tens/Units) 6	PC Only	Reset to Zero Only
55	56		Hours (Thou/Hunds) 6	PC Only	Reset to Zero Only
56	57	<b>(30)</b>	Fault 7	PC Only	Reset to Zero Only
57	58		Spare		
58	59		Hours (Tens/Units) 7	PC Only	Reset to Zero Only
59	60		Hours (Thou/Hunds) 7	PC Only	Reset to Zero Only
60	61	<b>(32)</b>	Fault 8	PC Only	Reset to Zero Only
61	62		Spare		
62	63		Hours (Tens/Units) 8	PC Only	Reset to Zero Only
63	64		Hours (Thou/Hunds) 8	PC Only	Reset to Zero Only
64	65	<b>(34)</b>	Fault 9	PC Only	Reset to Zero Only
65	66		Spare		
66	67		Hours (Tens/Units) 9	PC Only	Reset to Zero Only
67	68		Hours (Thou/Hunds) 9	PC Only	Reset to Zero Only
68	69	<b>(36)</b>	Fault 10	PC Only	Reset to Zero Only
69	70		Spare		
70	71		Hours (Tens/Units) 10	PC Only	Reset to Zero Only
71	72		Hours (Thou/Hunds) 10	PC Only	Reset to Zero Only
72	73	<b>(38)</b>	Fault 11	PC Only	Reset to Zero Only
73	74		Spare		
74	75		Hours (Tens/Units) 11	PC Only	Reset to Zero Only
75	76		Hours (Thou/Hunds) 11	PC Only	Reset to Zero Only
76	77	<b>(40)</b>	Fault 12	PC Only	Reset to Zero Only
77	78		Spare		
78	79		Hours (Tens/Units) 12	PC Only	Reset to Zero Only
79	80		Hours (Thou/Hunds) 12	PC Only	Reset to Zero Only
80	81	<b>(42)</b>	Fault 13	PC Only	Reset to Zero Only
81	82		Spare		
82	83		Hours (Tens/Units) 13	PC Only	Reset to Zero Only
83	84		Hours (Thou/Hunds) 13	PC Only	Reset to Zero Only
84	85	<b>(44)</b>	Fault 14	PC Only	Reset to Zero Only
85	86		Spare		
86	87		Hours (Tens/Units) 14	PC Only	Reset to Zero Only
87	88		Hours (Thou/Hunds) 14	PC Only	Reset to Zero Only
88	89	<b>(46)</b>	Fault 15	PC Only	Reset to Zero Only
89	90		Spare		
90	91		Hours (Tens/Units) 15	PC Only	Reset to Zero Only
91	92		Hours (Thou/Hunds) 15	PC Only	Reset to Zero Only
92	93	<b>(48)</b>	Fault 16	PC Only	Reset to Zero Only
93	94		Spare		
94	95		Hours (Tens/Units) 16	PC Only	Reset to Zero Only
95	96		Hours (Thou/Hunds) 16	PC Only	Reset to Zero Only
96	97	48	Dash Display CA-1	HS or PC	None
97	98	49	Dash Display SL2-1	HS or PC	None
98	99	50	Dash Display SL4-1	HS or PC	None
99	100	51	Spare-1	HS or PC	None

Numbers in ( **bold italic** ) are stored fault pointers

<b>E<sup>2</sup> No.</b>	<b>Func No.</b>	<b>HS No.</b>	<b>Function</b>	<b>Access By:</b>	<b>Restrictions</b>
100	101	52	Dash Display CA-2	HS or PC	None
101	102	53	Dash Display SL2-2	HS or PC	None
102	103	54	Dash Display SL4-2	HS or PC	None
103	104	55	Spare-2	HS or PC	None
104	105	56	Dash Display CA-3	HS or PC	None
105	106	57	Dash Display SL2-3	HS or PC	None
106	107	58	Dash Display SL4-3	HS or PC	None
107	108	59	Spare-3	HS or PC	None
108	109	60	Dash Display CA-4	HS or PC	None
109	110	61	Dash Display SL2-4	HS or PC	None
110	111	62	Dash Display SL4-4	HS or PC	None
111	112		Spare-4	PC Only	None
112	113		Secure HM (Tens/Units)	PC Only	OEM Read Only
113	114		Secure HM (Thou/Hund)	PC Only	OEM Read Only
114	115		Sec Aux HM (Tens/Units)	PC Only	OEM Read Only
115	116		Sec Aux HM (Thou/Hund)	PC Only	OEM Read Only
116	117		Reserved	PC Only	GE Future Use Only
117	118		Reserved	PC Only	GE Future Use Only
118	119		Reserved	PC Only	GE Future Use Only
119	120		Reserved	PC Only	GE Future Use Only
120	121		OEM Use	PC Only	None
121	122		OEM Use	PC Only	None
122	123		OEM Use	PC Only	None
123	124		OEM Use	PC Only	None
124	125		OEM Use	PC Only	None
125	126		OEM Use	PC Only	None
126	127		OEM Use	PC Only	None
127	128		OEM Use	PC Only	None





**GE Electric Vehicle Systems**

**INSTRUCTIONS  
EV100ZX HANDSET**

**GENERAL**

The Handset is a multi-functional tool to be used with the EV100/200 LX and LXT SCR controls. The Handset consist of a Light Emitting Diode (LED) display and a keyboard for data entry.

**PURPOSE:**

The purpose of the Handset is to allow **authorized personnel** to perform the following functions:

- Monitor existing system fault codes for both traction and pump SCR systems
- Monitor intermittent random status code
- Monitor battery state of charge
- Monitor hourmeter reading on traction and pump SCR systems
- Monitor or adjust the following control functions:
  - Creep speed
  - Controlled Acceleration and 1A time
  - Current Limit
  - Steer pump time delay and define signal input ( seat switch or directional switch )
  - Plugging distance (Current)
  - Pedal position plug range or disable
  - 1A drop out current or disable
  - Field Weakening drop out
  - Field Weakening pick up
  - Regen braking current limit
  - Regen braking drop out
  - Speed limit points ( SL1,SL2, and SL3)
  - Truck Management fault speed limit
  - Internal resistance compensation for battery state of charge indication
  - Battery voltage ( 36/48 volts is auto ranging )
- Selection of card operation type:
  - Standard traction card selection:
    - Standard traction with Field Weakening
    - Standard traction with Speed Limits
    - Standard traction with Regen/Field Weakening
  - High or low current limit for all of the above.

**OPERATION:**

**Warning : Before connecting or disconnecting the handset tool, jack up the drive wheels of the vehicle, turn off the key switch, unplug the battery and discharge the capacitors.**

At the SCR control traction card, unplug the " Y plug " if the dash display is in use and plug in the handset to the plug location " Y " on the control card. After installing the handset

tool, plug in the battery and turn on the key switch. The following is the start-up display sequence that will occur:

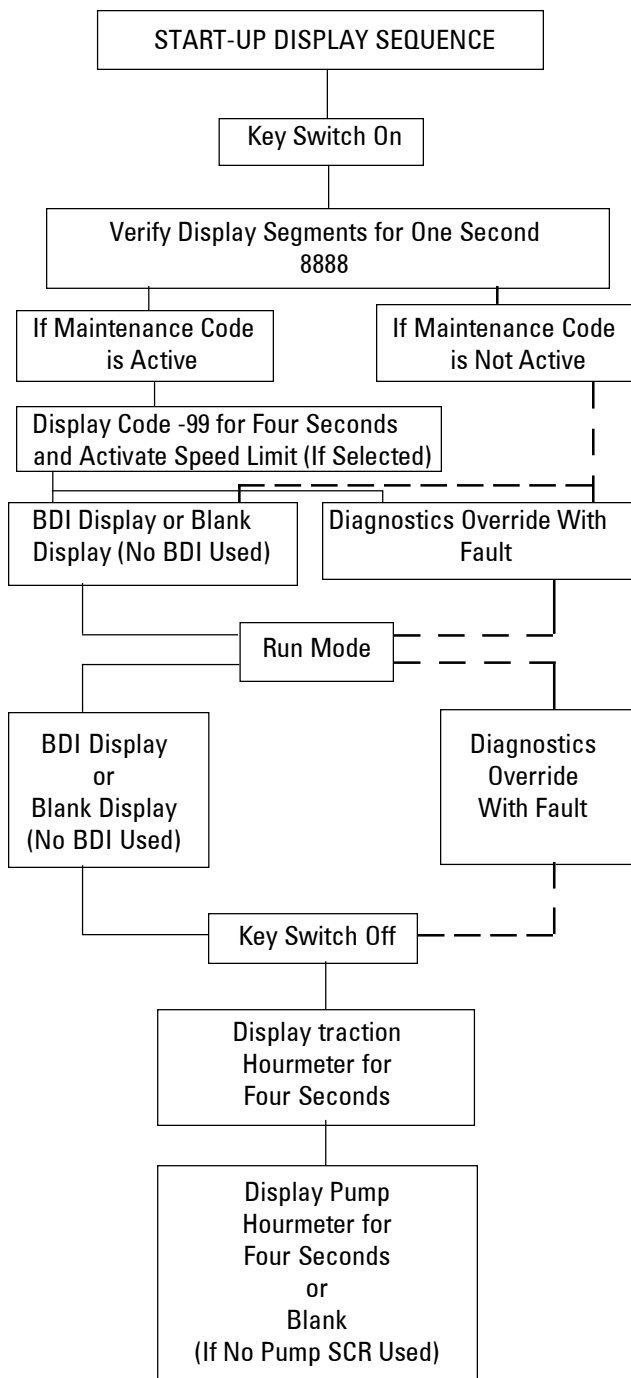

**NOTE:** The vehicle can be operated with the handset connected, **however, the adjustment knob must be set fully clockwise to insure the control operates at top speed.**

**FUNCTION SET-UP PROCEDURES:**

**Warning:** Before making any adjustments to the control you must consult the operating and maintenance instructions supplied by the vehicle manufacturer. Failure to follow proper set up instructions could result in misoperation or damage to the control system.

With the Handset connected , hold down the CONT key and turn on the key switch. This will place you in the set up mode, ready to monitor or adjust control function settings.

**NOTE:** The term push, means to depress key for approximately **one second**.

SET UP MODE		
Action	Display shows	Remarks
Hold down CONT, turn on key	8888	Segment check displayed
Push function number	U 005	Selected function number is displayed
After one second time delay	085	Stored value for the function is displayed
Push CONT		Displayed value will blink
Change value with adjustment knob		Value changes while blinking
Push STORE	125	New value stored and blinking stops
Push ESC	8888	Segment check displayed

At this point another function can be monitored/changed by pushing another function number, or the vehicle can be placed in the run mode by holding the ESC key down for one second or longer. The display will return to either the diagnostics mode or the BDI display or a blank display ( if BDI is not used and there are no fault codes). The vehicle can now be operated with the handset connected or the handset can be disconnected before operation.

**NOTE:** You can return to the segment check mode at any time, by holding down the ESC key until 8888 appears in the display.

**FAULT CODE SCROLLING**

The EV100 ZX controller furnishes a function register that contains the last 16 faults that shut down vehicle operation (PMT type fault that is reset by cycling the key switch) and the battery state of charge reading at the time the fault occurred. The first of the 16 status codes will be overwritten each time a new status code occurs. The stored status code register can be cleared from memory by using the handset.

The stored status codes can be accessed and cleared by using the following procedure:

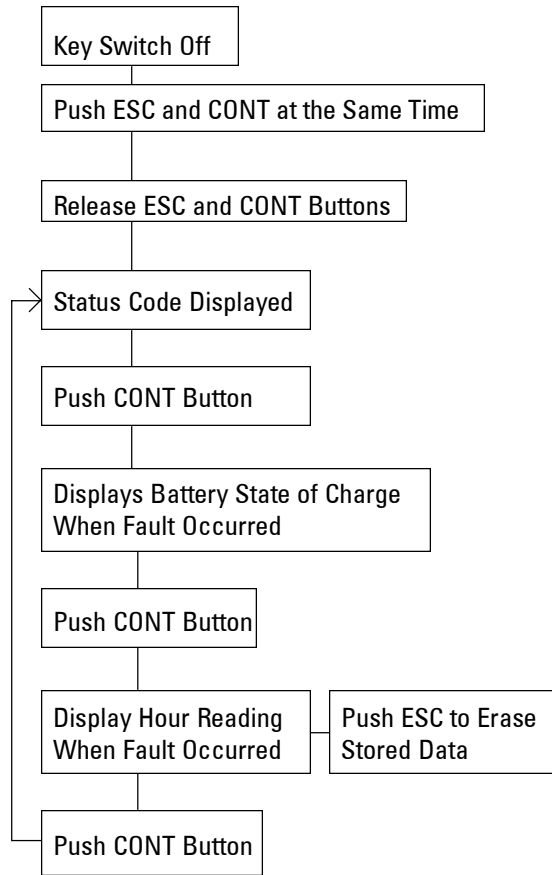

**DESCRIPTION AND LOCATION**

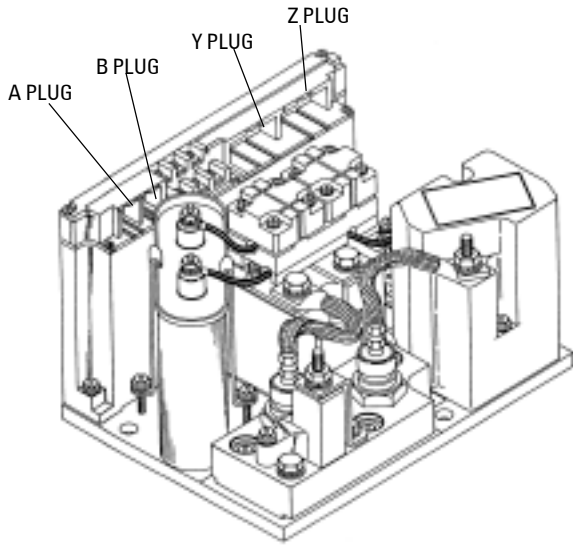

**EV100 LX/LXT/ZX**

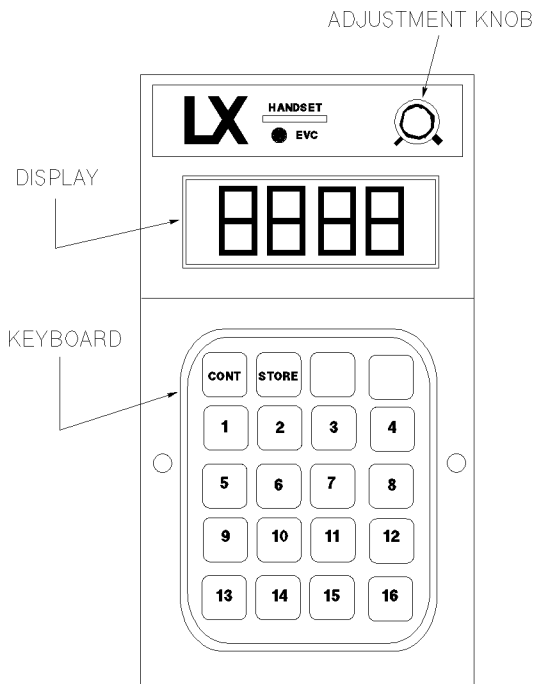

**DESCRIPTION OF FUNCTION NUMBERS FOR:**  
Control Cards IC3645EVLXCD1ZT, ZX, ZH and ZY

**FUNCTION 1 STORED FAULT CODE  
( Push 1 )**

This function register contains the last fault that shut down vehicle operation ( PMT type fault that is reset by cycling the key switch ). This fault code will be over written each time a new fault occurs and can be cleared from memory by adjusting the value to zero. **This register will be cleared when the battery is unplugged.**

**FUNCTION 2 CREEP SPEED  
( Push 2 )**

This function allows for the adjustment of the creep speed of the vehicle. A constant creep speed frequency will be maintained when an accelerator input voltage between 3.7 and 3.5 volts or an accelerator ohmic input between 6K and 4.7K ohms is provided.

Range 2% to 15% on time  
Set 0 to 255  
Resolution .03% per set unit

Example: Setting of 20 = 2.6% on time

**FUNCTION 3 CONTROLLED ACCELERATION  
AND 1A TIME  
( Push 3 )**

This function allows for the adjustment of the rate of time it takes for the control to accelerate to 96% applied battery voltage to the motor on hard acceleration. The 1A contactor will automatically close .2 seconds after the controlled acceleration stops and the accelerator input is less than .5 volts or less than 50 ohms.

Range .1 to 22.0 seconds  
Set 0 to 255  
Resolution .084 seconds per set unit

Example: Setting of 20 = 1.8 seconds C/A and 2.0 1A time.

**FUNCTION 4 CURRENT LIMIT  
( Push 4 )**

This function allows for the adjustment of the current limit of the control. The rating of the control will determine the range of adjustment for this function. Please refer to the operating instructions for the control used in your vehicle.

Range See control C/L curves  
Set 0 to 255  
Example: 0 = min. current, 255 = max. current

**FUNCTION 5 PLUGGING DISTANCE (CURRENT)  
( Push 5 )**

This function allows for the adjustment of the plugging distance of the vehicle. The larger the current setting, the shorter the stopping distance.

Range 200 to 1000 amps (EV100)  
300 to 1500 amps (EV200)  
Set 0 to 255  
Resolution 3.14 amps per set unit (EV100)  
4.7 amps per set unit (EV200)  
Example: Setting of 20 = 263 amps (EV100)

**Warning: Plug settings must be in accordance with control operating instructions. An excessively high setting could cause damage to control system or traction motor.**

**FUNCTION 6 1A DROP OUT CURRENT  
( Push 6 )**

This function allows for the adjustment of the 1A contactor drop out current. The 1A contactor will be dropped out and the vehicle motor torque will be limited to SCR current limit when the set drop out current is reached.

Range 450 to 1260 amps (EV100)  
675 to 1890 amps (EV200)  
Set 0 to 250  
Resolution 3.24 amps per set unit (EV100)  
4.86 amps per set unit (EV200)

Settings above 250 set units will disable 1A drop out function ( 1A will not drop out).

Example Setting of 20 = 515 amps (EV100)

**FUNCTION 7 FIELD WEAKENING PICK UP  
( Push 7 )**

This function allows the adjustment of field weakening contactor pick up current. This setting allows the FW contactor to pick up when the vehicle has returned to about 150% of its full load level running current after acceleration.

Range 52 to 466 amps (EV100)  
78 to 699 amps (EV200)  
Set 0 to 255  
Resolution 1.6 amps per set unit  
2.4 amps per set unit  
Example Setting of 20 = 84 amps

Note: The FW contactor will not pick up with a setting of less than 5.

**FUNCTION 8      FIELD WEAKENING DROP OUT  
                          ( Push 8 )**

This function allows for the adjustment of the field weakening contactor drop out current. This setting allows the FW contactor to drop out when the vehicle requires greater than 300% of the full load level running current for greater torque.

Range            65 to 895 amps (EV100)  
                          98 to 1343 amps (EV200)  
Set                0 to 255  
Resolution      3.25 amps per set unit (EV100)  
                          4.88 amps per set unit (EV200)  
Example         Setting of 20 = 130 amps

**FUNCTION 9      REGEN BRAKING C/L  
                          ( Push 9 )**

This function allows for the adjustment of the Regen braking current limit. The higher the current the shorter the stopping distance.

Range            75 to 630 amps  
Set                0 to 255  
Resolution      2.2 amps per set unit  
Example:         Setting of 20 = 119 amps

**FUNCTION 10     REGEN START  
                          ( Push 10 )**

This function allows for the adjustment of the percent on time at which the control will start to regen. Adjustment of this function allows the OEM to set the regen start speed of the vehicle to eliminate regen attempts when motor regen current is low.

Range            0 to 95% on time  
Set                0 to 255  
Resolution      .37% per set unit  
Example:         Setting of 20 = 7.4% on time

**FUNCTION 11     SPEED LIMIT 1 (SL1)  
                          ( Push 11 )**

This function allows for the adjustment of the speed limit (maximum battery volts to the motor) when the SL1 limit switch input signal is received by the control card. SL1 limit switch is a normally closed switch connected to battery negative, the switch opening enables speed limit.

Range            96% to 0% battery volts  
Set                0 to 180

Setting of 0 set units will disable speed limit function and allow top speed with no limit switch connected.

**FUNCTION 12     SPEED LIMIT 2 (SL2)  
                          ( Push 12 )**

Same as Function 11 except using SL2 limit switch for input.

**FUNCTION 13     SPEED LIMIT 3 (SL3)  
                          ( Push 13 )**

Same as Function 11 except using SL3 limit switch for input.

The SL3 set speed limit is also activated by the Truck Management Module fault codes 90 and 93. See instructions for IC3645TMM1A Truck Management Module for details.

**FUNCTION 14     INTERNAL RESISTANCE  
                          COMPENSATION  
                          ( Push 14 )**

This function is used when the Battery Discharge Indicator is present. Adjustment of this function will improve the accuracy of the BDI. In order to made this setting the voltage drop of the battery under load must first be determined by following the steps listed below.

1. Load the traction motor to 100 amps in 1A and record the voltage ( $V_0$ ) at the SCR positive and negative power terminal.
2. Load the traction motor to 200 amps in 1A and record the voltage ( $V_L$ ) at the SCR positive and negative power terminal.
3. Calculate voltage drop ( $V_D$ ) as follows:  
 $V_D = V_0 - V_L$
4. Use the table below to determine the setting using the calculated  $V_D$  as a reference.

Setting	EV100 VD	EV200 VD	Setting	EV100 VD	EV200 VD
2	11.44	07.63	17	01.34	00.89
3	07.60	05.07	18	01.27	00.85
4	05.72	03.81	19	01.20	00.80
5	04.57	03.05	20	01.14	00.76
6	03.81	02.54	21	01.09	00.73
7	03.27	02.18	22	01.04	00.69
8	02.86	01.91	23	00.99	00.66
9	02.54	01.69	24	00.95	00.63
10	02.28	01.52	25	00.91	00.61
11	02.08	01.39	26	00.88	00.59
12	01.90	01.27	27	00.85	00.57
13	01.76	01.17	28	00.82	00.55
14	01.63	01.08	29	00.79	00.53
15	01.52	01.01	30	00.76	00.51
16	01.43	00.95	31	00.74	00.49

**FUNCTION 15     BATTERY VOLTS  
                          ( Push 15 )**

This function allows for the adjustment of voltage range for controls equipped with the Battery Discharge Indication function. In order for the BDI to operate properly, the setting as shown in the table must be entered .

Battery volts	Set units
24 volts	Between 0 and 31
36 volts	Between 32 and 44
48 volts	Between 45 and 69
72 volts	Between 70 and 80
80 volts	Between 81 and 183
36/48 volts	Between 184 and 250
No BDI	Between 251 and 255

***The following functions have function numbers larger than the numbers on the Handset keyboard. To access these functions, push the CONT key and the number shown in the following instructions at the same time.***

### **The Seat Switch must be open.**

#### **FUNCTION 16 PEDAL POSITION PLUG ( Push CONT and 1 )**

This function will allow the adjustment of the pedal position plug range. Pedal position will reduce the plugging current to the current value set by this function as the accelerator is returned to the creep speed position. Maximum plug current is obtained with the accelerator in the top speed position.

Range	100 to 930 amps (EV100) 150 to 1425 amps (EV200)
Set	0 to 255
Resolution	3.2 amps per set unit (EV100) 5.0 amps per set unit (EV200)
Example	Setting of 20 = 164 amps

To disable the pedal position plug function, adjust the current value to the same current value as the plug distance current.

Example: If plug distance current Function 5 is set at 500 amps, then set pedal plug current at 500 amps. With this setting pedal position will have no effect on plugging distance.

#### **FUNCTION 17 CARD TYPE SELECTION ( Push CONT and 2 )**

This function allows for the selection of the card type used for your vehicle's application. The table below shows the setting to select card application type depending on which control card is used.

EV100 Function	Standard with FW Limit	Speed Regen/FW
STD C/L 0 to 4	20 to 24	40 to 44
High C/L 5 to 9	25 to 29	45 to 49
STD C/L (Auto plug)	10 to 14	30 to 34 50 to 54

High C/L  
(Auto plug) 15 to 19 35 to 39 55 to 59

#### **EV200 Standard Speed Function with FW Limit Regen/FW**

STD C/L 64 to 68 84 to 88 104 to 108  
STD C/L  
(Auto plug) 74 to 78 94 to 98 114 to 118

Settings for these function should be made in between the values shown.

**Warning: These settings must be changed by authorized personnel only, following instructions supplied by the manufacturer. Card type selection must be made within the capabilities of the SCR control panel used and the supporting electro-mechanical devices. Failure to comply with proper application standards could result in misoperation or damage to the control and/or motors.**

#### **FUNCTION 18 STEER PUMP TIME DELAY ( Push CONT and 3 )**

This function allows for the selection of steer pump contactor pick up input, either seat switch or directional switch closing and adjustment of the time delay for the contactor drop out.

**Pick up on seat switch closure and time delay drop out on seat switch opening.**

Range	1.5 to 65 seconds
Setting	Between 0 and 128
Resolution	.5 seconds per set unit

Example: Setting of 20 = 10.5 seconds

**Pick up on directional switch closure and drop out time delay on directional switch opening.**

Range	.5 to 63 seconds
Setting	129 to 255
Resolution	.5 seconds per set unit
Example:	Setting of 149 = 10.5 seconds

Drop out will be 1.5 seconds after the seat switch opens.

#### **FUNCTION 19 MAINTENANCE CODE TENS AND UNITS HOURS SET (Push CONT 4)**

This function allows for the adjustment of the tens and units hours of the maintenance code activation time.

Range 0 to 99  
 Set 0 to 99  
 Example 9999 hours (bold numbers are set by this function)

**FUNCTION 20 MAINTENANCE CODE THOUSANDS AND HUNDREDS HOURS SET (Push CONT 5)**

This function allows for the adjustment of the thousand and hundred hours of the maintenance code activation time.

Range 0 to 99  
 Set 0 to 99  
 Example 9999 Hours (bold numbers are set by this function)

**FUNCTION 21 MAINTENANCE CODE SPEED LIMIT (Push CONT 6)**

This function allows for the adjustment of the speed limit (maximum battery volts to the motor) when the maintenance code is activated by the control card.

Range 100% to 0% battery volts  
 Set 0 to 180  
 Resolution -0.56% per set unit  
 Example Setting of 20 = 88.8% battery volts

**FUNCTION 28 FAULT CODE POINTER (Push CONT 13)**

This register contains the location of the last fault recorded of the 16 stored status codes.

To determine which stored status code was the last one recorded, read the number stored in Function 28. Using the memory map for your logic card, match the fault code pointer number (the number shown in ***bold italics***) in the HS number column) on the memory map, with the number obtained from Function 28. This will be the last fault recorded. Note: When scrolling the fault register, the register always starts at Fault 1 and scrolls to Fault 16. Instructions for scrolling the register are on page 68 of the instruction book.

**FUNCTION 29 TENS AND UNITS HOURS SET (Push CONT 14)**

This function allows for the adjustment of the tens and units hours of the hourmeter.

Range 0 to 99  
 Set 0 to 99  
 Example 9999 hours (bold numbers are set by this function)

**FUNCTION 30 THOUSANDS AND HUNDREDS HOURS SET (Push CONT 15)**

Range 0 to 99  
 Set 0 to 99  
 Example 9999 hours (bold numbers are set by this function)

This function allows for the adjustment of the thousand and hundred hours of the hourmeter.

***The following functions have function numbers larger than the numbers on the Handset keyboard. To access these functions, push the CONT key and the number shown in the following instructions at the same time.***

***The Seat Switch must be closed.***

The following functions (Functions 48 - 62) are mode settings that are activated from the display. Each function must be set by using the logic table shown below. If you try to set the function outside these guidelines, an error code will be displayed to prompt you to enter the correct setting  
 If: 80 is displayed, the setting is too low  
 If: 81 is displayed, the setting is too high

Setting Logic Table

	Mode 1	Mode 2	Mode 3	Mode 4
C/A Time	=> Mode 2	=< Mode 1 => Mode 3	=< Mode 2 => Mode 4	=< Mode 3
FW Pickup	=< Mode 2	=> Mode 1 =< Mode 3	=> Mode 2 =< Mode 4	=> Mode 3
SL1	=> Mode 2	=< Mode 1 => Mode 3	=< Mode 2 => Mode 4	=< Mode 3

**FUNCTION 48 MODE 1 CONTROLLED ACCELERATION AND 1A TIME (Push CONT1)**

This function allows for the adjustment of the rate of time it takes for the control to accelerate to 96% applied battery voltage to the motor on hard acceleration. The 1A contactor will automatically close 0.2 seconds after the controlled acceleration stops and the accelerator input is less than 0.5 volts or less than 50 ohms. **This CA and 1A time takes effect when the Mode 1 settings are called for by the interactive dash display.**

Range 0.1 to 22.0 seconds  
 Set 0 to 255  
 Resolution 0.084 seconds per set unit  
 Example Setting of 20 = 1.8 seconds C/A and 2.0 1A time

**FUNCTION 49    MODE 1 - FIELD WEAKENING PICK UP  
(Push CONT 2)**

This function allows the adjustment of field weakening contactor pick up current. This setting allows the FW contactor to pick up when the vehicle has returned to about 150% of its full load level running current after acceleration. **This FW pick-up value takes effect when the Mode 1 settings are called for by the interactive Dash Display.**

Range	52 to 466 amps (EV100) 78 to 699 amps (EV200)
Set	0 to 255
Resolution	1.6 amps per set unit (EV100) 2.4 amps per set unit (EV200)
Example	Setting of 20 = 84 amps (EV100) Setting of 20 = 126 amps (EV200)

**FUNCTION 50    MODE 1 - SPEED LIMIT 1 (SL1)  
(Push CONT 3)**

This function allows for the adjustment of the speed limit (maximum battery volts to the motor) that is activated whenever Mode 1 is selected by the operator. **No speed limit switch is required for this function. Therefore, to disable the function, this register must be set to zero.**

Range	96% to 0% battery volts
Set	0 to 180

Setting of 0 set units will disable speed limit function and allow top speed with no limit switch connected. **This speed limit (SL1) value takes effect when the Mode 1 settings are called for by the interactive Dash Display.**

**FUNCTION 52    MODE 2 - CONTROLLED ACCELERATION  
AND 1A TIME  
(Push CONT 5)**

Same as Function 48.

**This CA and 1A time takes effect when the Mode 2 settings are called for by the interactive dash display.**

**FUNCTION 53    MODE 2 - FIELD WEAKENING PICK UP  
(Push CONT 6)**

Same as Function 49.

**This FW pick-up value takes effect when the Mode 2 settings are called for by the interactive Dash Display.**

**FUNCTION 54    MODE 2 - SPEED LIMIT 1 (SL1)  
(Push CONT 7)**

Same as Function 50.

**This speed limit (SL1) value takes effect when the Mode 2 settings are called for by the interactive Dash Display.**

**FUNCTION 56    MODE 3 - CONTROLLED ACCELERATION  
AND 1A TIME  
(Push CONT 9)**

Same as Function 48.

**This CA and 1A time takes effect when the Mode 3 settings are called for by the interactive dash display.**

**FUNCTION 57    MODE 3 - FIELD WEAKENING PICK UP  
(Push CONT 10)**

Same as Function 49.

**This FW pick-up value takes effect when the Mode 3 settings are called for by the interactive Dash Display.**

**FUNCTION 58    MODE 3 - SPEED LIMIT 1 (SL1)  
(Push CONT 11)**

Same as Function 50.

**This speed limit (SL1) value takes effect when the Mode 3 settings are called for by the interactive Dash Display.**

**FUNCTION 60    MODE 4 - CONTROLLED ACCELERATION  
AND 1A TIME  
(Push CONT 13)**

Same as Function 48.

**This CA and 1A time takes effect when the Mode 4 settings are called for by the interactive dash display.**



**DESCRIPTION OF FUNCTION NUMBERS FOR:**  
Control Cards IC3645EVLXCD1ZP

**FUNCTION 1 STORED FAULT CODE**  
( Push 1 )

This function register contains the last fault that shut down vehicle operation ( PMT type fault that is reset by cycling the key switch ). This fault code will be over written each time a new fault occurs and can be cleared from memory by adjusting the value to zero. **This register will be cleared when the battery is unplugged.**

**FUNCTION 2 INTERNAL RESISTANCE COMPENSATION START**  
( Push 2 )

This function allows for the adjustment of the current level at which the internal resistance compensation feature (Function 16) will take effect.

Range 0 to 1325 amps  
Set 0 to 255  
Resolution 6.5 amps per set unit  
Example: Setting of 72 = 130 amps

**FUNCTION 3 CONTROLLED ACCELERATION AND 1A TIME**  
( Push 3 )

This function allows for the adjustment of the rate of time it takes for the control to accelerate to 96% applied battery voltage to the motor on hard acceleration. The 1A contactor will automatically close 0.2 seconds after the controlled acceleration stops and the accelerator input is less than 0.5 volts or less than 50 ohms.

Range .1 to 5.5 seconds  
Set 0 to 255  
Resolution .021 seconds per set unit  
Example: Setting of 20 = 0.52 seconds C/A and 0.72 seconds 1A time.

**FUNCTION 4 CURRENT LIMIT**  
( Push 4 )

This function allows for the adjustment of the current limit of the control. The rating of the control will determine the range of adjustment for this function. Please refer to the operating instructions for the control used in your vehicle.

Range See control C/L curves  
Set 0 to 255  
Example: 0 = min. current, 255 = max. current

**FUNCTION 7 INTERNAL RESISTANCE COMPENSATION RATE**  
( Push 7 )

This function allows for the adjustment of the rate of time it takes for the control to add the internal resistance compensation voltage that is applied to the motor. This function will add 0.375 volts to the motor at the rate of time adjusted until the total IR compensation voltage has been added.

Range 0.0015 to 0.383 seconds  
Set 0 to 255  
Resolution 0.0015 seconds per set unit  
Example: Setting of 20 = 0.032 seconds

**FUNCTION 11 SPEED LIMIT 1 (SL1)**  
( Push 11 )

This function allows for the adjustment of the speed limit (maximum battery volts to the motor) when the SL1 limit switch input signal is received by the control card. SL1 limit switch is a normally open switch connected to battery negative, the switch closing enables speed limit.

Range 0% to 100% battery volts  
Set 0 to 255  
Resolution 0.375 volts per set unit  
Example Setting of 50 = 18.75 volts

**FUNCTION 12 SPEED LIMIT 2 (SL2)**  
( Push 12 )

Same as Function 11 except using SL2 limit switch for input.

**FUNCTION 13 SPEED LIMIT 3 (SL3)**  
( Push 13 )

Same as Function 11 except using SL3 limit switch for input.

**FUNCTION 13 SPEED LIMIT 4 (SL4)**  
( Push 13 )

Same as Function 11 except using SL4 limit switch for input.

**The following functions have function numbers larger than the numbers on the Handset keyboard. To access these functions, push the CONT key and the number shown in the following instructions at the same time.**

**The Seat Switch must be open.**

**FUNCTION 16 SPEED/TORQUE COMPENSATION  
( Push CONT 1 )**

This function is used to stabilize pump speed at heavy loads. The voltage selected will be added to the motor at each 100 amp increment starting at the value set in Function 2. The voltage compensation selected will be added in increments of 0.375 volts until the entire voltage is added. For example, a setting of 2 will be added in 30 steps of 0.375 volts each, whereas a setting of 4 will be added in 15 steps of 0.375 volts each.

**SPEED/TORQUE COMPENSATION TABLE**

Setting	Voltage Drop	Setting	Voltage Drop
2	11.44	17	01.34
3	07.60	18	01.27
4	05.72	19	01.20
5	04.57	20	01.14
6	03.81	21	01.09
7	03.27	22	01.04
8	02.86	23	00.99
9	02.54	24	00.95
10	02.28	25	00.91
11	02.08	26	00.88
12	01.90	27	00.85
13	01.76	28	00.82
14	01.63	29	00.79
15	01.52	30	00.76
16	01.43	31	00.74

**FUNCTION 17 CARD TYPE SELECTION  
(Push CONT 2)**

This function allows for the selection of the card type used for your vehicle's application. The table below shows the setting to select card application type depending on which control card is used.

Function	With Pump Ctr/PMT	Without Pump Ctr/PMT
STD C/L	0 to 8	36 to 44
High C/L	9 to 17	45 to 53
STD C/L		
BDI (Lockout)	18 to 26	54 to 62
High C/L		
BDI (Lockout)	27 to 35	63 to 71

Settings for these function should be made in between the values shown.

**Warning: These settings must be changed by authorized**

**personnel only, following instructions supplied by the manufacturer. Card type selection must be made within the capabilities of the SCR control panel used and the supporting electro-mechanical devices. Failure to comply with proper application standards could result in misoperation or damage to the control and/or motors.**

**FUNCTION 28 FAULT CODE POINTER  
(Push CONT 13)**

This register contains the location of the last fault recorded of the 16 stored status codes.

To determine which stored status code was the last one recorded, read the number stored in Function 28. Using the memory map for your logic card, match the fault code pointer number (the number shown in ***bold italics***) in the HS number column) on the memory map, with the number obtained from Function 28. This will be the last fault recorded. Note: When scrolling the fault register, the register always starts at Fault 1 and scrolls to Fault 16. Instructions for scrolling the register are on page 68 of the instruction book.

***The following functions have function numbers larger than the numbers on the Handset keyboard. To access these functions, push the CONT key and the number shown in the following instructions at the same time.***

***The Seat Switch must be closed.***

The following functions (Functions 48 - 62) are mode settings that are activated from the display. Each function must be set by using the logic table shown below. If you try to set the function outside these guidelines, an error code will be displayed to prompt you to enter the correct setting

If: 80 is displayed, the setting is too low

If: 81 is displayed, the setting is too high

**Setting Logic Table**

	Mode 1	Mode 2	Mode 3	Mode 4
<b>C/A Time</b>	=> Mode 2	=< Mode 1 => Mode 3	=< Mode 2 => Mode 4	=< Mode 3
<b>FW Pickup</b>	=< Mode 2	=> Mode 1 =< Mode 3	=> Mode 2 =< Mode 4	=> Mode 3
<b>SL1</b>	=> Mode 2	=< Mode 1 => Mode 3	=< Mode 2 => Mode 4	=< Mode 3

**FUNCTION 48 MODE 1 CONTROLLED ACCELERATION AND 1A TIME  
(Push CONT1)**

This function allows for the adjustment of the rate of time it takes for the control to accelerate to 96% applied battery voltage to the motor on hard acceleration. The 1A contactor will automatically close 0.2 seconds after the controlled acceleration stops and the accelerator input is less than 0.5 volts or less than 50 ohms. **This CA and 1A time takes effect when the Mode 1 settings are called for by the interactive dash display.**

Range 0.1 to 22.0 seconds  
 Set 0 to 255  
 Resolution 0.084 seconds per set unit  
 Example Setting of 20 = 1.8 seconds C/A and 2.0 1A time

**FUNCTION 49 MODE 1 - SPEED LIMIT 2 (SL2)  
 ( Push CONT 2)**

This function allows for the adjustment of the speed limit (maximum battery volts to the motor) when the SL2 limit switch input signal is received by the control card. SL2 limit switch is a normally open switch connected to battery negative, the switch closing enables speed limit. **This Speed Limit 2 (SL2) takes effect when the Mode 1 settings are called for by the interactive Dash Display.**

Range 0% to 100% battery volts  
 Set 0 to 255  
 Resolution 0.375 volts per set unit  
 Example Setting of 50 = 18.75 volts

**FUNCTION 50 MODE 1 - SPEED LIMIT 4 (SL4)  
 (Push CONT 3)**

This function allows for the adjustment of the speed limit (maximum battery volts to the motor) when the SL4 limit switch input signal is received by the control card. SL4 limit switch is a normally open switch connected to battery negative, the switch closing enables speed limit. **This Speed Limit 4 (SL4) takes effect when the Mode 1 settings are called for by the interactive Dash Display.**

Range 0% to 100% battery volts  
 Set 0 to 255  
 Resolution 0.375 volts per set unit  
 Example Setting of 50 = 18.75 volts

**FUNCTION 52 MODE 2 - CONTROLLED ACCELERATION AND 1A TIME  
 (Push CONT 5)**

Same as Function 48.

**This CA and 1A time takes effect when the Mode 2 settings are called for by the interactive dash display.**

**FUNCTION 53 MODE 2 - SPEED LIMIT 2 (SL2)  
 (Push CONT 6)**

Same as Function 49.

**This Speed Limit 2 (SL2) takes effect when the Mode 2 settings are called for by the interactive Dash Display.**

**FUNCTION 54 MODE 2 - SPEED LIMIT 4 (SL4)  
 (Push CONT 7)**

Same as Function 50.

**This Speed Limit 4 (SL4) takes effect when the Mode 2 settings are called for by the interactive Dash Display.**

**FUNCTION 56 MODE 3 - CONTROLLED ACCELERATION AND 1A TIME  
 (Push CONT 9)**

Same as Function 48.

**This CA and 1A time takes effect when the Mode 3 settings are called for by the interactive dash display.**

**FUNCTION 57 MODE 3 - SPEED LIMIT 2 (SL2)  
 (Push CONT 10)**

Same as Function 49.

**This Speed Limit 2 (SL2) takes effect when the Mode 3 settings are called for by the interactive Dash Display.**

**FUNCTION 58 MODE 3 - SPEED LIMIT 4 (SL4)  
 (Push CONT 11)**

Same as Function 50.

**This Speed Limit 4 (SL4) takes effect when the Mode 3 settings are called for by the interactive Dash Display.**

**FUNCTION 60 MODE 4 - CONTROLLED ACCELERATION AND 1A TIME  
 (Push CONT 13)**

Same as Function 48.

**This CA and 1A time takes effect when the Mode 4 settings are called for by the interactive dash display.**

**FUNCTION 61 MODE 4 - SPEED LIMIT 2 (SL2)  
 (Push CONT 14)**

Same as Function 49.

**This Speed Limit 2 (SL2) takes effect when the Mode 4 settings are called for by the interactive Dash Display.**

**FUNCTION 62 MODE 4 - SPEED LIMIT 4 (SL4)  
 (Push CONT 15)**

Same as Function 50.

**This Speed Limit 4 (SL4) takes effect when the Mode 4 settings are called for by the interactive Dash Display.**