



**ZAPI**<sup>®</sup> S.p.A.

**ELECTRONIC • OLEODYNAMIC • INDUSTRIAL  
EQUIPMENTS CONSTRUCTION**

Via Parma, 59 – 42028 – POVIGLIO (RE) – ITALY  
Tel +39 0522 960050 (r.a.) – Fax +39 0522 960259  
e-mail: [zapi@zapispa.it](mailto:zapi@zapispa.it) – web: [www.zapispa.it](http://www.zapispa.it)



*User Manual*

# COMBI AC1



All rights reserved

The contents of this publication is a ZAPI S.p.A. property; all related authorizations are covered by Copyright. Any partial or total reproduction is prohibited.

Under no circumstances will Zapi S.p.A. be held responsible to third parties for damage caused by the improper use of the present publication and of the device/devices described in it.

Zapi spa reserves the right to make changes or improvements to its products at any time and without notice.

The present publication reflects the characteristics of the product described at the moment of distribution. The publication therefore does not reflect any changes in the characteristics of the product as a result of updating.



**ZAPI**® is a registered trademark property of Zapi S.p.A.

## NOTES LEGEND



*The symbol aboard is used inside this publication to indicate an annotation or a suggestion you should pay attention.*

---



***The symbol aboard is used inside this publication to indicate an action or a characteristic very important as for security. Pay special attention to the annotations pointed out with this symbol.***

---

# Contents

<b>1</b>	<b>INTRODUCTION</b>	<b>6</b>
<b>2</b>	<b>SPECIFICATION</b>	<b>7</b>
2.1	Technical specifications	7
2.2	Block diagrams	7
<b>3</b>	<b>SPECIFICATION FOR THE INPUT DEVICES FILLING UP THE INSTALLATION KIT</b>	<b>8</b>
3.1	Digital inputs	8
3.1.1	DIs technical details – 24 V system	8
3.1.2	DIs technical details – 48 V system	8
3.1.3	Microswitches	8
3.2	Analog unit	9
3.3	Other analog control unit	9
3.4	Analog motor thermal sensor input	10
3.5	Speed feedback	10
<b>4</b>	<b>INSTALLATION HINTS</b>	<b>11</b>
4.1	Material overview	11
4.1.1	Connection cables	11
4.1.2	Contactors	11
4.1.3	Fuses	12
4.2	Installation of the hardware	12
4.2.1	Positioning and cooling of the controller	12
4.2.2	Wirings: power cables	13
4.2.3	Wirings: CAN connections and possible interferences	13
4.2.4	Wirings: I/O connections	15
4.2.5	Connection of the encoder	16
4.2.6	Main contactor and key connection	17
4.2.7	Insulation of truck frame	18
4.3	Protection and safety features	19
4.3.1	Protection features	19
4.3.2	Safety Features	20
4.4	EMC	20
4.5	Various suggestions	22
<b>5</b>	<b>OPERATIONAL FEATURES</b>	<b>23</b>
5.1	Diagnosis	23
<b>6</b>	<b>DESCRIPTION OF THE CONNECTORS</b>	<b>24</b>
6.1	Connectors of the logic	24
6.1.1	CNA connector: AmpSaab Version	25
6.1.2	CNA connector: AmpSeal version	26
6.2	Description of power connections	28
<b>7</b>	<b>DRAWINGS</b>	<b>29</b>
7.1	Mechanical drawing	29
7.2	Connection drawing	30
7.2.1	AmpSaab version	30
7.2.2	AmpSeal version	31
<b>8</b>	<b>ONE SHOT INSTALLATION PROCEDURE</b>	<b>32</b>
8.1	Sequence for Ac Inverter traction setting	33
<b>9</b>	<b>PROGRAMMING &amp; ADJUSTMENTS USING DIGITAL CONSOLE</b>	<b>35</b>
9.1	Adjustments via console	35

9.2	Description of console (hand set) & connection .....	35
9.3	Description of the console menu .....	36
9.3.1	Master: AmpSaab version .....	36
9.3.2	Master: AmpSeal version .....	37
9.3.3	Slave: AmpSaab version .....	38
9.3.4	Slave: AmpSeal version .....	39
9.4	Function configuration (MASTER).....	40
9.4.1	Config menu “SET OPTIONS” functions list.....	40
9.4.2	Config menu “ADJUSTMENTS” functions list .....	42
9.4.3	Main menu “PARAMETER CHANGE” functions list.....	44
9.4.4	Zapi menu “SPECIAL ADJUSTMENTS” functions list.....	47
9.4.5	Main menu “TESTER” functions list .....	48
9.5	Function configuration (SLAVE) .....	51
9.5.1	Config menu “SET OPTIONS” functions list.....	51
9.5.2	Config menu “ADJUSTMENTS” functions list .....	51
9.5.3	Config menu “PARAMETER CHANGE” functions list .....	52
9.5.4	Config menu “SPECIAL ADJUSTMENTS ” functions list .....	54
9.5.5	Config menu “TESTER ” functions list.....	55
<b>10</b>	<b>OTHER FUNCTIONS .....</b>	<b>57</b>
10.1	Description of console “SAVE” function .....	57
10.2	Description of console “RESTORE” function.....	58
10.3	Description of console “PROGRAM VACC” function.....	59
10.4	Description of the throttle regulation.....	61
10.5	Description of the battery charge detection setting .....	62
<b>11</b>	<b>COMBI AC1 ALARMS LIST .....</b>	<b>64</b>
11.1	Faults diagnostic system .....	64
11.2	Master microcontroller alarms overview .....	65
11.3	Analysis and troubleshooting of Master microcontroller alarms .....	66
11.4	Master warnings overview .....	72
11.5	Analysis and troubleshooting of Master warnings .....	73
11.6	Slave alarms overview .....	76
11.7	Analysis and troubleshooting of Slave alarms.....	77
11.8	Slave warnings overview.....	80
11.9	Analysis and troubleshooting of Slave warnings .....	81
<b>12</b>	<b>RECOMMENDED SPARE PARTS .....</b>	<b>85</b>
<b>13</b>	<b>PERIODIC MAINTENANCE TO BE REPEATED AT TIMES INDICATED.....</b>	<b>86</b>

## APPROVAL SIGNS

COMPANY FUNCTION	INIZIALS	SIGN
GRAPHIC AND LAYOUT	FF	
PROJECT MANAGER	FG	
TECHNICAL ELECTRONIC MANAGER VISA	PP	
SALES MANAGER VISA	PN	

Publication N°: AEQZP0BA  
Edition: August 2005

# 1 INTRODUCTION

The COMBI AC1 inverter has been developed to perform all the electric functions that are usually presents in walkie trucks, stackers, low order pickers etc. The controller can perform the following functions:

- Controller for Ac 700W to 3.5Kw AC motors;
- Pump controller for series wounded DC motors up to 7,5 Kw.
- Drivers for ON/OFF electrovalves and for one proportional valve (electrodistributor)
- Can bus interface
- Interface for serial tiller head, canbus tiller or serial tiller
- Zapi patented sensorless control
- Flash memory.
- Double microcontroller (one for main tasks, one for safety related tasks)

# 2 SPECIFICATION

## 2.1 Technical specifications

Inverter for traction AC asynchronous 3-phase motors plus chopper for DC series pump motors.  
 Regenerative braking functions.  
 Digital control based upon microcontroller

Voltage: ..... 24, 36, 48V  
 Inverter maximum current (24V, 36V): ..... 350A (RMS) for 2'  
 Inverter maximum current (36V, 48V): ..... 300A (RMS) for 2'  
 Inverter operating frequency: ..... 8kHz  
 Dc chopper Maximum current (24V,36V): ..... 350A for 2'  
 Dc chopper Maximum current (36V, 48V): ..... 300A for 2'  
 Chopper Operating frequency: ..... 16kHz  
 External temperature working range: ..... -40°C ÷ 40°C  
 Maximum heatsink temperature (start of the thermal cutback) ..... 85°C

## 2.2 Block diagrams

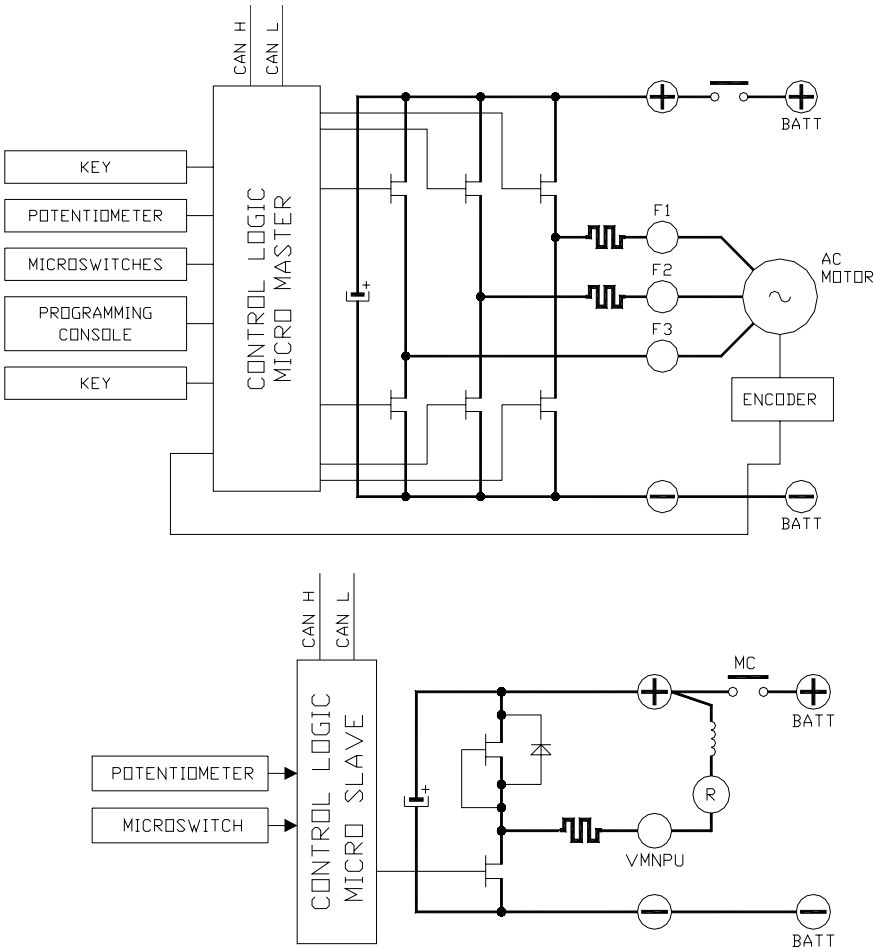

# 3 SPECIFICATION FOR THE INPUT DEVICES FILLING UP THE INSTALLATION KIT

## 3.1 Digital inputs

Combi Ac1 digital inputs work in the voltage range [-B; +B]. Related command devices (microswitches) must be connected to +B (typically to key voltage).

Pull-down resistance to -B is built-in.

Functional devices (like FW, BACK, LIFT, DESCENT, HORN, H&S, TILLER, BELLY switches) are Normally Open; so related function becomes active when the microswitch closes.

Safety devices (like CUTBACK, LIFTING CUTOFF switches) are Normally Closed; so related function becomes active when the microswitches opens.

A number of Dis are input to both microcontrollers, for safety purpose (double-check in real time). They are listed here following:

- AMP SAAB version: A7, A5, A11, A18, A19, A20, A33, A34, A35, A6
- AMP SEAL version: A1, A20, A6, A32, A31, A19, A7, A35, A17, A29

It is recommended to connect SAFETY RELATED devices to these double-checked inputs, in order to increase the application safety level.

### 3.1.1 Dis technical details – 24 V system

- Switching threshold: 3V [ $\pm 0,5V$ ]
- Input impedance: 4,7kOhm [ $\pm 0,5kOhm$ ]

### 3.1.2 Dis technical details – 48 V system

- Switching threshold: 3V [ $\pm 0,5V$ ]
- Input impedance: 13kOhm [ $\pm 1kOhm$ ]

### 3.1.3 Microswitches

- It is suggested that microswitches have a contact resistance lower than 0,1Ohm and a leakage current lower than 100 $\mu A$ .
- When full load connected, the voltage between the key switch contacts must be lower than 0.1V.
- If the microswitch to be used has different characteristic, it is suggested to discuss them and their application with Zapi technicians.



## 3.2 Analog unit

The analog input can be connected to an accelerator unit if the Zapi can or serial tiller is not used.

The accelerator unit can consist of a potentiometer or an Hall effect device. It should be in a 3-wire configuration. The potentiometer is supplied through CNA#26 [AmpSaab connector] OR CNA#25 [Ampseal connector].

Potentiometer output signal must be input to CPOT (CNA#24 for AmpSaab connector, CNA#15 for Ampseal connector) signal range is from 0 to 10V.

The negative supply of the potentiometer has to be taken from CNA#23 [AmpSaab connector] OR CNA#5 [AmpSeal connector]

Potentiometer value should be in the 0.5 - 10 K $\Omega$  range; generally, the load should be in the 1.5mA to 30mA range. Faults can occur if it is outside this range. This AI is input to both microcontrollers, for safety purpose (double check in real time).

The standard connection for the potentiometer is the one in the Left side of next figure (potentiometer on one end at rest) in combination with a couple of Travel demand switches (figure refers to AmpSaab connector). On request it is also possible the handling in the Right side of next figure (potentiometer in the middle at rest) still in combination with a couple of Travel demand switches.

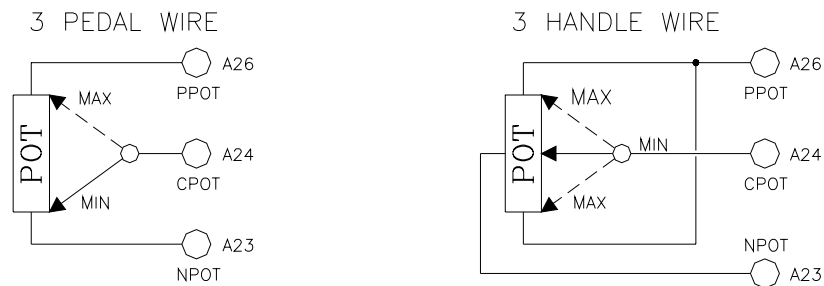

The Procedure for automatic potentiometer signal acquisition is carried out using the Hand Set. This enables adjustment of the minimum and maximum useful signal level, in either direction.

## 3.3 Other analog control unit

If the Zapi can tiller is not used, input CNA#25 [AmpSaab connector] or CNA#30 [AmpSeal connector] is an analog input, whose typical application is a proportional command to enable a lifting/lowering function. It is possible to use this input for an alternative function like a proportional braking.

It should be in a 3 wire configuration. Potentiometer value should be in the 0.5-10K $\Omega$  range. Generally, the load should be in the 1.5mA to 30 mA range.

The CPOTL [CNA#25 AmpSaab connector, CNA#30 AmpSeal connector] signal range is from 0 to 10V.

Use CNA#26 [CNA#25] (positive) and CNA#41 [CNA#5] (negative) to supply it. In the AmpSaab version the NPOT input [CNA#23] can be used as third analog input. In this case use CAN#41 as negative supply of the traction potentiometer (the "PEDAL WIRE KO" warning is lost).

Also in AmpSeal version a third analog input is available in CNA#17 (a digital input is lost).

These other two analog inputs are checked by both microcontrollers too.

---

### 3.4 Analog motor thermal sensor input

Input CNA#12 in the AmpSaab version [CNA#22 in AmpSeal connector] is an analog input to receive an analog thermal sensor signal to measure the Traction Motor Winding Temperature. The analog device installed in the motor has to be specified, in order to insert the correct look-up table in the software. A digital device can also be used.

---

### 3.5 Speed feedback

The motor control is based upon the motor speed feedback (sensored software). The speed transducer is an incremental encoder, with two phases shifted at 90°. The encoder can be of different types :

- power supply: +12V

- electric output: open collector ( NPN or PNP), push-pull.

COMBI AC1 could also be used without encoder, sensorless control.

This solution has to be discussed with Zapi technicians.



*Note: The encoder resolution and the motor poles pair (the controller can handle), is specified in the home page display of the handset showing following headline:*

*CA1S2AE    ZP1.07*

*That means:*

*CA1S= COMBIAC1 traction controller*

*2 = motor's poles pair number*

*A = 32 pulses/rev encoder*

*E = identifier for an extended memory hardware release inside*

*The encoder resolution is given by the second-last letter in the following list:*

*A = 32 pulses/rev*

*K = 48 pulses/rev*

*B = 64 pulses/rev*

*C = 80 pulses/rev*

---

## 4 INSTALLATION HINTS

In the description of these installation suggestions you will find some boxes of different colours, they mean:



These are **informations** useful for anyone is working on the installation, or a deeper examination of the content

---



These are **Warning boxes**, they describe:

- operations that can lead to a failure of the electronic device or can be dangerous or harmful for the operator;
- items which are important to guarantee system performance and safety

---

### 4.1 Material overview

Before to start it is necessary to have the required material for a correct installation. Otherwise a wrong choice of cables or other parts could lead to failures/ misbehaviour/ bad performances.

#### 4.1.1 Connection cables

For the auxiliary circuits, use cables 0.5mm<sup>2</sup> section at least.  
For power connections to the motor and to the battery, use cables having section of 16-25 mm<sup>2</sup>.  
For the optimum inverter performance, the cables to the battery should be run side by side and be as short as possible.

#### 4.1.2 Contactors

IT IS STRONGLY RECCOMENDED TO USE A MAIN CONTACTOR to connect and cut off the battery to the controller. Depending on the setting of a parameter in the controller:

- the output which drives the main contactor coil is on/off (the coil is driven with the full battery voltage).
- the output which drives the main contactor coil is switched at high frequency (1 KHz) with a programmable duty cycle; this feature is useful to decrease the power dissipation of the contactor coil.



**The EN1175 states the main Contactor is not mandatory (under proper conditions); anyway it is recommended to protect the inverter against reverse battery polarity and to cut off the battery from the power mosfets when a failure in the three phase bridge occurs.**

---

### 4.1.3 Fuses

- Use a 6.3-10A Fuse for protection of the auxiliary circuits.
- For protection of the power unit, use a 400A fuse in the Battery Positive connection. For special applications or requirements these values can be reduced.
- For Safety reasons, we recommend the use of protected fuses in order to prevent the spread of fused particles should the fuse blow.

---

## 4.2 Installation of the hardware

---



***Before doing any operation, ensure that the battery is disconnected and when all the installation is completed start the machine with the drive wheels raised from the floor to ensure that any installation error do not compromise safety.***

***After operation, even with the Key Switch open, the internal capacitors may remain charged for some time. For safe operation, we recommend that the battery is disconnected, and a short circuit is made between Battery Positive and Battery Negative power terminals of the chopper using a Resistor between 10 Ohm and 100 Ohm. Minimum 5 Watts.***

---

### 4.2.1 Positioning and cooling of the controller

**CONTROLLER WITH BASE PLATE:** Install the controller with the base-plate on a flat metallic surface that is clean and unpainted; suggested characteristics are: planarity 0.05 mm and rugosity 1.6  $\mu\text{m}$

- Apply a light layer of thermo-conductive grease between the two surfaces to permit better heat dissipation.
- The heat generated by the power block must be dissipated. For this to be possible, the compartment must be ventilated and the heat sink materials ample.
- The heat sink material and system should be sized on the performance requirement of the machine. Abnormal ambient air temperatures should be considered. In situations where either ventilation is poor, or heat exchange is difficult, forced air ventilation should be used.
- The thermal energy dissipated by the power block module varies and is dependent on the current drawn and the duty cycle.

**CONTROLLER WITH FINNED HEATSINK:** Sometimes the base plate installation cannot be adopted. Due to positioning problems or to the lack of a thick enough truck frame, it is necessary to adopt a finned dissipation combined with one or more fans.

- The air flux should hit the fins directly, to maximize the cooling effect.
- In addition to fans, also air ducting systems can be used to maintain low the temperature of the controller.
- It is necessary to ensure that cold air is taken from outside the controller compartment and hot air is easily pushed away from the controller compartment.
- It is mandatory to avoid that the cooling air is recirculated inside the controller compartment.

## 4.2.2 Wirings: power cables

- The power cables length must be as short as possible to minimize power losses.
- They must be tightened on controller power posts with a Torque of 13-15 Nm
- The COMBI AC-1 module should only be connected to a traction battery. Do not use converters outputs or power supplies. For special applications please contact the nearest Zapi Service Centre.



**Do not connect the controller to a battery with a nominal voltage different than the value indicated on the controller label. A higher battery voltage may cause MOS failure. A lower voltage may prevent the logic operating.**

---

## 4.2.3 Wirings: CAN connections and possible interferences



*CAN Stands for Controller Area Network. It is a communication protocol for real time control applications. CAN operates at data rate of up to 1 Megabits per second.*

*It was invented by the German company Bosch to be used in the car industry to permit communication among the various electronic modules of a vehicle, connected as illustrated in this image:*

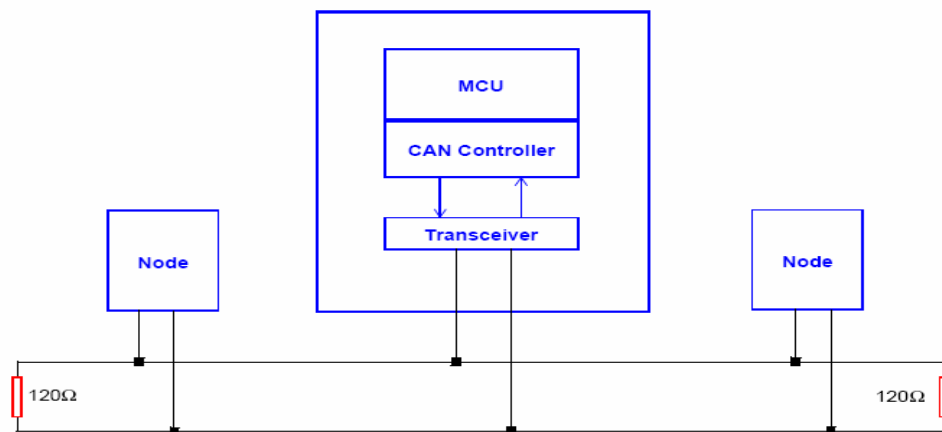

- 
- The best cable for can connections is the twisted pair; if it is necessary to increase the immunity of the system to disturbances, a good choice would be to use a cable with a shield connected to the frame of the truck. Sometimes it is sufficient a simple double wire cable or a duplex cable not shielded.
  - In a system like an industrial truck, where power cables carry hundreds of Ampere, there are voltage drops due to the impedance of the cables, and that could cause errors on the data transmitted through the can wires. In the following figures there is an overview of wrong and right layouts of the cables routing.



### **Wrong Layout:**

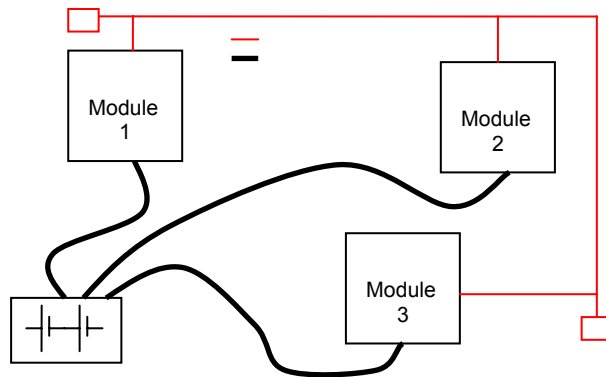

The red lines are can wires.  
The black boxes are different modules, for example traction controller, pump controller and display connected by canbus.  
The black lines are the power cables.

This is apparently a good layout, but can bring to errors in the can line.  
The best solution depends on the type of nodes (modules) connected in the network.  
If the modules are very different in terms of power, then the preferable connection is the daisy chain.



### **Correct Layout:**

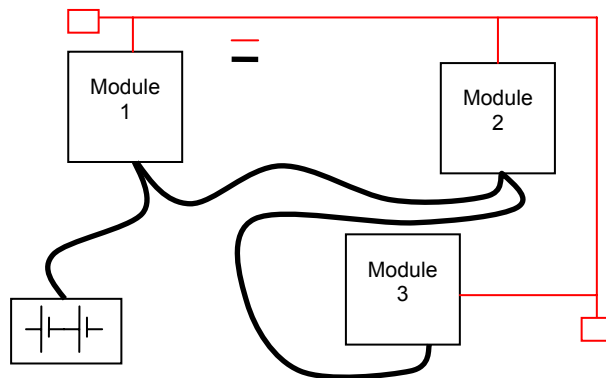

**Note: Module 1 power > Module 2 power > Module 3 power**

The chain starts from the –BATT post of the controller that works with the highest current, and the others are connected in a decreasing order of power.

Otherwise, if two controllers are similar in power (for example a traction and a pump motor controller) and a third module works with less current, the best way to deal this configuration is to create a common ground point (star configuration)



### **Correct Layout:**

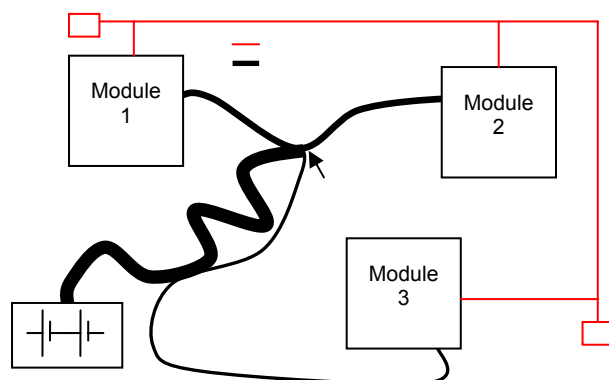

**Note: Module 1 power  $\approx$  Module 2 power > Module 3 power**

---

In this case the power cables starting from the two similar controllers must be as short as possible. Of course also the diameter of the cable concurs in the voltage drops described before (higher diameter means lower impedance), so in this last example the cable between the minus of the Battery and the common ground point (pointed by the arrow in the image) must be dimensioned taking into account thermal and voltage drop problems.



### Can advantages

*The complexity of today systems needs more and more data, signal and information must flow from a node to another. CAN is the solution to different problems that arise from this complexity*

- *simplified design (readily available, multi sourced components and tools)*
- *lower costs (less and smaller cables )*
- *improved reliability (fewer connections)*
- *analysis of problems improved (easy connection with a pc to read the data flowing through the cable)*

---

## **4.2.4 Wirings: I/O connections**

- After crimping the cable, verify that all strands are entrapped in the wire barrel.
- Verify that all the crimped contacts are completely inserted on the connector cavities



***A cable connected to the wrong pin can lead to short circuits and failure; so, before turning on the truck for the first time, verify with a multimeter the continuity between the starting point and the end of a signal wire***

- 
- for information about the mating connector pin assignment see the paragraph “description of the connectors”

## 4.2.5 Connection of the encoder

- 1) COMBI AC1 card is fit for different types of encoder. To control AC motor with Zapi inverter, it is necessary to install an incremental encoder with 2 phases shifted of 90°. The encoder power supply can be +5 or +12V. It can have different electronic output.

### AMPSAAB VERSION

A9	+5V/+12V	positive of encoder power supply.
A10	GND	negative of encoder power supply.
A8	A	phase A of encoder.
A22	B	phase B of encoder.

### AMPSEAL VERSION

A25	+5V/+12V	positive of encoder power supply.
A5	GND	negative of encoder power supply.
A14	A	phase A of encoder.
A13	B	phase B of encoder.

- 2) Connection of encoder with open collector output; +5V power supply.

### AMPSAAB VERSION

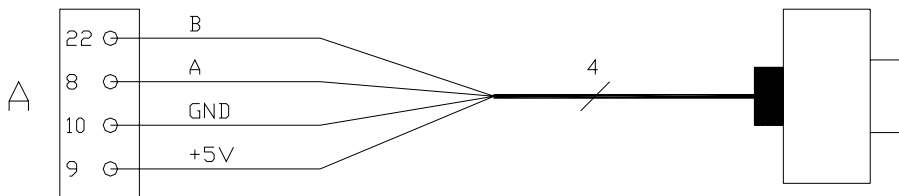

### AMPSEAL VERSION

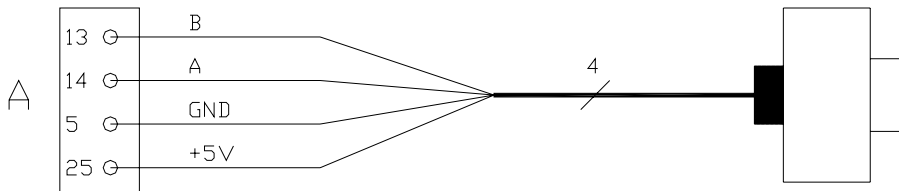

Connection of encoder with open collector output: +12V power supply.

### AMPSAAB VERSION

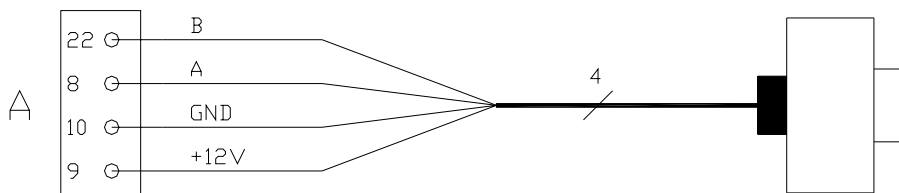



## AMPSEAL VERSION

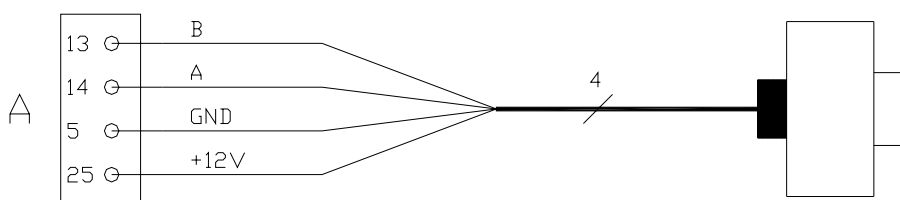

### VERY IMPORTANT

*It is necessary to specify in the order the type of encoder used, in terms of power supply, electronic output and n° of pulses for revolution, because the logic unit must be set in the correct way by Zapi.*

*The n° of pulses revolution the controller can handle is given by the second-last letter in the software release name (see 3.5).*

## 4.2.6 Main contactor and key connection

- The connection of the main contactor can be carried out following the drawing in the figure.

### AMPSAAB VERSION

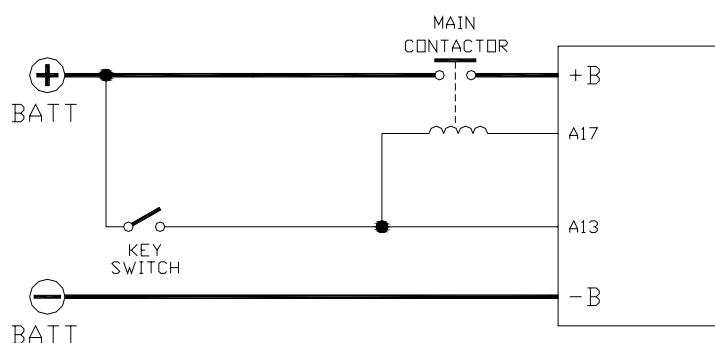

### AMPSEAL VERSION

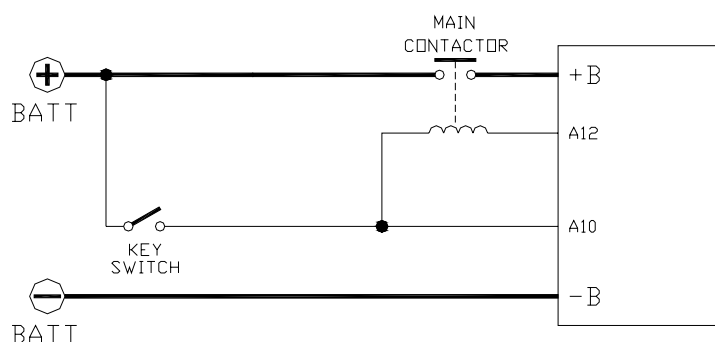

- The connection of the battery line switches must be carried out following ZAPI instructions.
- If a mechanical battery line switch is installed, it is strongly recommended that the key supply to the inverter is open together with power battery line (see picture below); if not, the inverter may be damaged if the switch is opened during a regenerative braking.
- An intrinsic protection is present inside the logic when the voltage on the battery power connection overtakes 40% more than the battery nominal

voltage or if the key is switched off before the battery power line is disconnected.

#### AMPSAAB VERSION

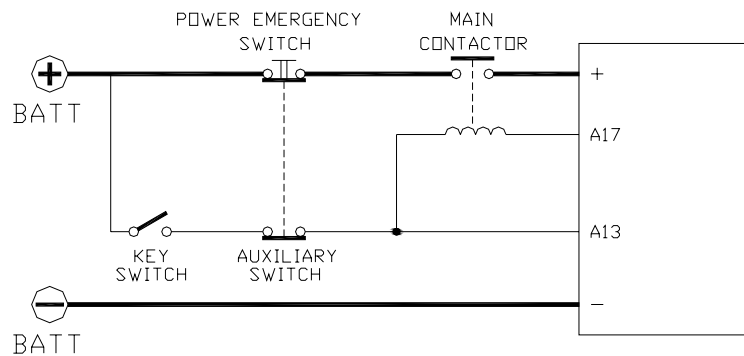

#### AMPSEAL VERSION

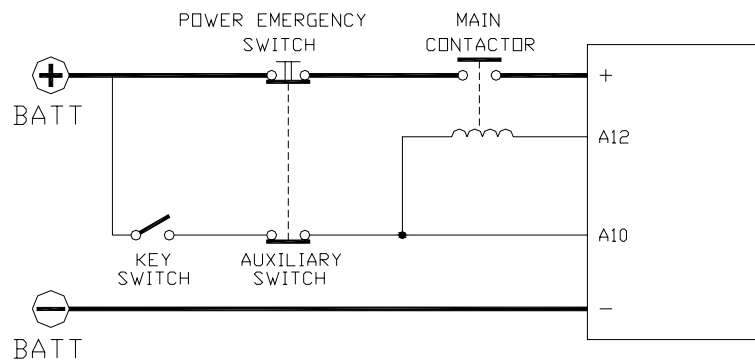

### 4.2.7 Insulation of truck frame



**As stated by EN-1175 “Safety of machinery – Industrial truck”, chapter 5.7, “there shall be no electrical connection to the truck frame”. So the truck frame has to be isolated from any electrical potential of the truck power line.**

## 4.3 Protection and safety features

### 4.3.1 Protection features

The COMBI AC1 is protected against some controller injuries and malfunctions:

- **Battery polarity inversion**

It is necessary to fit a LINE CONTACTOR to protect the controller against reverse battery polarity and for safety reasons.

- **Connection Errors**

All inputs are protected against connection errors.

- **Thermal protection**

If the controller temperature exceeds 85°C, the maximum current is reduced in proportion to the thermal increase. The temperature can never exceed 105°C.

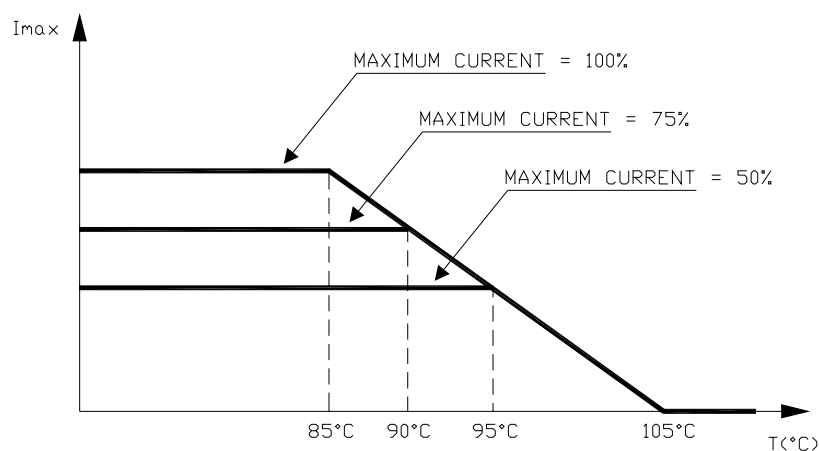

- **External agents**

The inverter is protected against dust and the spray of liquid to a degree of protection meeting IP65. Nevertheless, it is suggested to carefully study controller installation and position. With few simple shrewdness, the degree of controller protection can be strongly increased.

- **Protection against uncontrolled movements**

The main contactor will not close if:

- The Power unit is not functioning.
- The Logic or CANBUS interface is not functioning perfectly.
- The Can Tiller is not operating correctly.
- Running microswitches are in open position.

- **Low battery charge**

when the battery charge is low, the maximum current is reduced to the half of the maximum current programmed; additionally an alarm message is displayed.

- **Protection against accidental Start up**

A precise sequence of operations are necessary before the machine will start. Operation cannot begin if these operations are not carried out correctly.

Requests for drive must be made after closing the key switch.

## 4.3.2 Safety Features



***ZAPI controllers are designed according to the prEN954-1 specifications for safety related parts of control system and to UNI EN1175-1 norm. The safety of the machine is strongly related to installation; length, layout and screening of electrical connections have to be carefully designed. ZAPI is always available to cooperate with the customer in order to evaluate installation and connection solutions. Furthermore, ZAPI is available to develop new SW or HW solutions to improve the safety of the machine, according to customer requirements. Machine manufacturer holds the responsibility for the truck safety features and related approval.***

COMBI AC1 electronic implements a double  $\mu\text{C}$  structure. The second  $\mu\text{C}$  main task is to check correct functionality of the first  $\mu\text{C}$ , whose main task is to control traction AC motor. In more detail:

- first microcontroller manages Ac traction motor control and **hydraulic safety related functions.**
- second microcontroller manages Dc pump motor control, valves control and **traction safety related functions.**

**Basically, the two microcontrollers implement a double check control of the main functions.**

## 4.4 EMC



***EMC and ESD performances of an electronic system are strongly influenced by the installation. Special attention must be given to the lengths and the paths of the electric connections and the shields. This situation is beyond ZAPI's control. Zapi can offer assistance and suggestions, based on its years experience, on EMC related items. However, ZAPI declines any responsibility for non-compliance, malfunctions and failures, if correct testing is not made. The machine manufacturer holds the responsibility to carry out machine validation, based on existing norms (EN12895 for industrial truck; EN50081-2 for other applications).***

EMC stands for Electromagnetic Compatibility, and it represents the studies and the tests on the electromagnetic energy generated or received by an electrical device.

So the analysis works in two directions:

- 1) The study of the **emission** problems, the disturbances generated by the device and the possible countermeasure to prevent the propagation of that energy; we talk about “conduction” issues when guiding structures such wires and cables are involved, “radiated emissions” issues when it is studied the propagation of electromagnetic energy through the open space. In our case the origin of the disturbances can be found inside the controller with the

switching of the mosfets which are working at high frequency and generate RF energy, **but wires and cables have the key role to propagate the disturbs because they works as antennas**, so a good layout of the cables and their shielding can solve the majority of the emission problems.

- 2) The study of the **immunity** can be divided in two main branches: protection from electromagnetic fields and from electrostatic discharge. The **electromagnetic immunity** concern the susceptibility of the controller with regard to electromagnetic fields and their influence on the correct work made by the electronic device. There are well defined tests which the machine has to be exposed to. These tests are carried out at determined levels of electromagnetic fields, to simulate external undesired disturbances and verify the electronic devices response.
- 3) The second type of immunity, **ESD**, concerns the prevention of the effects of electric current due to excessive electric charge stored in an object. In fact, when a charge is created on a material and it remains there, it becomes an "electrostatic charge"; ESD happen when there is a rapid transfer from a charged object to another. This rapid transfer has, in turn, two important effects:
  - this rapid charge transfer can determine, by induction, disturbs on the signal wiring and thus create malfunctions; **this effect is particularly critical in modern machines, with serial communications (canbus) which are spread everywhere on the truck and which carry critical informations.**
  - in the worst case and when the amount of charge is very high, the discharge process can determine failures in the electronic devices; the type of failure can vary from an intermittently malfunction to a completely failure of the electronic device.

**IMPORTANT NOTE:** it is always much easier and cheaper to avoid ESD from being generated, than to increase the level of immunity of the electronic devices.

There are different solutions for EMC issues, depending on level of emissions/ immunity required, the type of controller, materials and position of the wires and electronic components.

- 1) **EMISSIONS.** Three ways can be followed to reduce the emissions:
  - A) **SOURCE OF EMISSIONS:** finding the main source of disturb and work on it.
  - B) **SHIELDING:** enclosing contactor and controller in a shielded box; using shielded cables;
  - C) **LAYOUT:** a good layout of the cables can minimize the antenna effect; cables running nearby the truck frame or in iron channels connected to truck frames is generally a suggested not expensive solution to reduce the emission level.
- 2) **ELECTROMAGNETIC IMMUNITY.** The considerations made for emissions are valid also for immunity. Additionally, further protection can be achieved with ferrite beads and bypass capacitors.

- 3) **ELECTROSTATIC IMMUNITY.** Three ways can be followed to prevent damages from ESD:
- A) **PREVENTION:** when handling ESD-sensitive electronic parts, ensure the operator is grounded; test grounding devices on a daily basis for correct functioning; this precaution is particularly important during controller handling in the storing and installation phase.
  - B) **ISOLATION:** use anti-static containers when transferring ESD-sensitive material.
  - C) **GROUNDING:** when a complete isolation cannot be achieved, a good grounding can divert the discharge current trough a “safe” path; the frame of a truck can works like a “local earth ground”, absorbing excess charge. **So it is strongly suggested to connect to truck frame all the parts of the truck which can be touched by the operator, who is most of the time the source of ESD.**

---

## 4.5 Various suggestions

- Never combine SCR low frequency choppers with COMBI AC1 modules. The filter capacitors contained in the COMBI AC1 module would change the SCR chopper operation and subject to excessive workload. If it is necessary to use two or more control units, like the chopper should both be of the Zapimos family.
- During battery recharge, the COMBI AC-1 must be completely disconnected from the battery. Beside changing the charging current seen by the battery charger, the module can be damaged by higher than normal voltages supplied via the charger.

# 5 OPERATIONAL FEATURES

- Speed control.
- Optimum behaviour on a slope if the speed feedback is used:
  - The motor speed follows the accelerator, starting a regenerative braking if the speed overtakes the speed set-point
  - The system can perform an electrical stop on a ramp (the machine is electrically hold on a slope) for a programmable time (if encoder is used)
- Stable speed in every position of the accelerator.
- Regenerative release braking based upon deceleration ramps.
- Regenerative braking when the accelerator pedal is partially released (deceleration).
- Direction inversion with regenerative braking based upon deceleration ramp.
- Regenerative braking and direction inversion without contactors: only the main contactor is present.
- The release braking ramp can be modulated by an analog input, so that a proportional brake feature is obtained.
- Optimum sensitivity at low speeds.
- Voltage boost at the start and with overload to obtain more torque (with current control).
- The inverter can drive an electromechanical brake.
- High efficiency of motor and battery due to high frequency commutations.
- Modification of parameters through the programming console.
- Internal hour-meter with values that can be displayed on the console.
- Memory of the last five alarms with relative hour-meter and temperature displayed on the console.
- Test function within console for checking main parameters.
- Direct communication between traction AC inverter and pump DC chopper.

---

## 5.1 Diagnosis

The microcontrollers continually monitor the inverter and the chopper and carry out diagnostic procedures on the main functions.

The diagnosis is made in 4 points:

- 1) Diagnosis at start-up that checks: watch-dog, Current Sensors, Capacitor charging, phase's voltages, pump motor output, contactor drivers, can-bus interface, presence of a start requirement, connection with the Can Tiller.
- 2) Standby Diagnosis that checks: watch-dog, phase's voltages, pump motor output, Contactor Drivers, Current Sensors, can-bus interface.
- 3) Driving diagnosis that checks: Watchdog, Current sensors, Contactor(s), can-bus interface.
- 4) Continuous Diagnosis that checks: power stage temperature, motor temperature, Battery Voltage.

Error codes are provided in two ways. The digital console can be used, which gives a detailed information about the failure; the failure code is also sent on the Can-Bus.

## 6 DESCRIPTION OF THE CONNECTORS

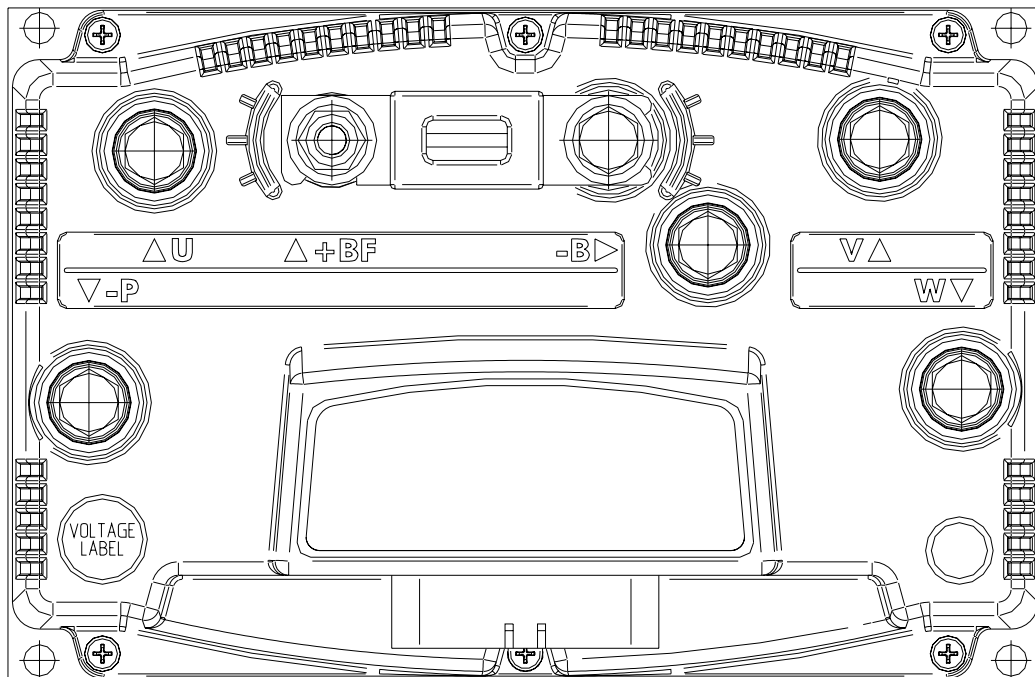

### 6.1 Connectors of the logic

AmpSaab version

AMP Junior Power Timer (SAAB CONN.)  
42P Header CONNECTOR  
(mate with housing receptacle P/N 1-0967281-1)

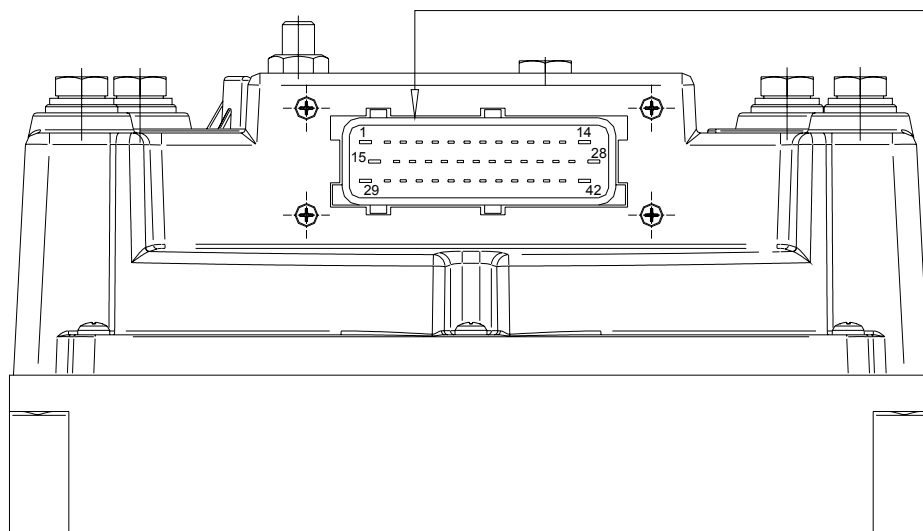



AMPSEAL 35P Header CONNECTOR  
(mate with Plug CONN. P/N 776164-1)

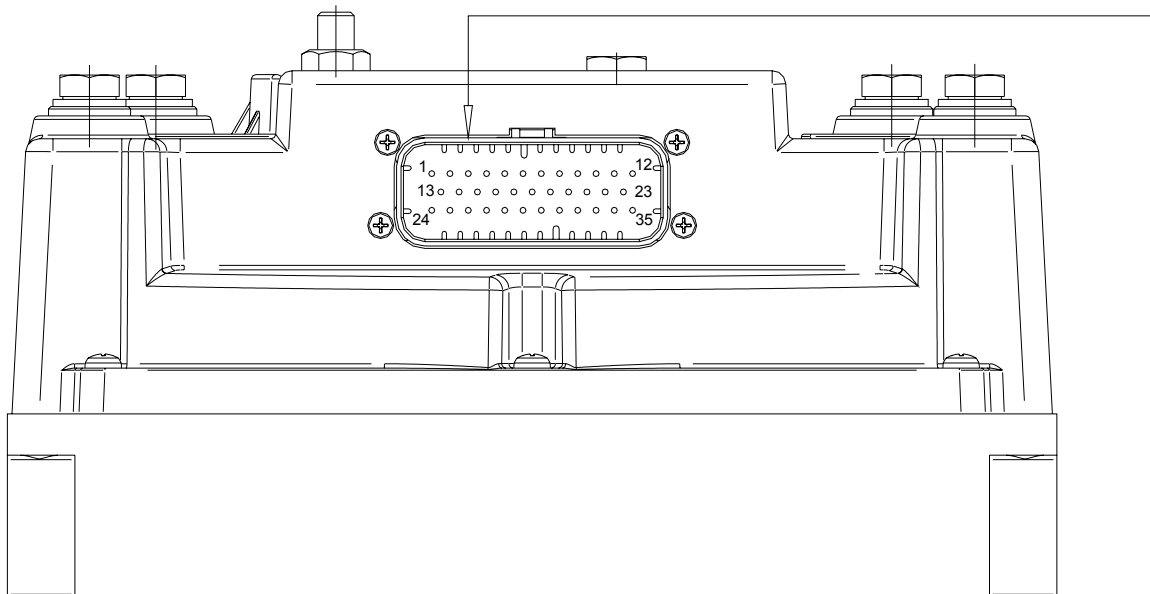

### 6.1.1 CNA connector: AmpSaab Version

The connector used is a AMPSAAB plug 42 pins

A1	NCLTXD	Negative serial transmission pin.
A2	PCLTXD	Positive serial transmission pin.
A3	NEVP	Negative of the proportional electrovalve.
A4	PAUX	Positive supply for electrovalves. This input has to be supplied with positive taken after main contactor and should be used to supply all electrovalves.
A5	DESCENT	Lowering request input active high.
A6	H&S	Hard & Soft request input. Must be connected to the Hard & Soft microswitch, active high.
A7	TILLER	Tiller microswitch input, active high (+VB).
A8	ENC A	Traction motor encoder phase A.
A9	PENC	Encoder Positive Supply (+5 or +12Vdc)
A10	NENC	Negative of the Encoder
A11	CUTBACK	Speed reduction switch input #1. Active low (switch opened)
A12	THMOT	Traction motor thermal sensor input. The internal pull-up is a fixed 2mA (Max 5V) source current.
A13	+KEY	Input of the key switch signal.
A14	NEV1	Output of the electrovalve 1 driver (driving to -Batt)
A15	NEV2	Output of the electrovalve 2 driver (driving to -Batt)
A16	NEV3	Output of the electrovalve 3 driver (driving to -Batt)
A17	NMC	Output of the Line Contactor coil driver (driving to -Batt)

A18	FW	Forward switch input, active high (+VB).
A19	BACK	Reverse switch input, active high (+VB).
A20	IN5	Input of the switch DIGITAL INPUT # 5.
A21	HORN	Horn switch input, active high (+VB).
A22	ENC B	Traction motor encoder phase B.
A23	NPOT	Negative of the accelerator potentiometer, tested for wire disconnection diagnosis.
A24	CPOTTR	Accelerator potentiometer wiper.
A25	CPOTL	Lift potentiometer wiper.
A26	PPOT	Positive of the potentiometers; 10 volts output; keep load > 1kohm
A27	CANH	High level CAN-BUS voltage I/O.
A28	NEV4	Output of the electrovalve 4 driver (driving to –Batt).
A29	NCLRXD	Negative serial reception pin.
A30	PEB	Positive of the electromechanical brake coil.
A31	NEB	EB coil driver output; pwm controlled 2A continuous (driving to –Batt).
A32	NEV5/HORN OUT	Output of the electrovalve 5/horn driver (driving to –Batt).
A33	BELLY	Quick inversion function input, must be connected to the belly microswitch. It is active high (+VB).
A34	IN7	Input of the switch DIGITAL INPUT # 7.
A35	IN8	Input of the switch DIGITAL INPUT # 8.
A36	LIFT SW	Lift request switch input, active high (+VB).
A37	LIFTING CUTOUT	Lift stop input. Active low.
A38	IN12	Input of the switch DIGITAL INPUT # 12.
A39	NEV6	Output of the electrovalve 6 driver (driving to –Batt).
A40	BOOTSTRAP	Flash memory bootstrap.
A41	GND	Negative of the lift potentiometer.
A42	CANL	Low level CAN-BUS voltage I/O.

### 6.1.2 CNA connector: AmpSeal version

The connector used is an AMPSEAL plug 35 pins

A1	TILLER	Tiller microswitch input, active high (+VB).
A2	PEB	Positive of the electromechanical brake.
A3	PAUX	Positive supply for electrovalves. This input has to be supplied with positive taken after main contactor and should be used to supply all electrovalves.
A4	NEB	EB coil driver output; pwm controlled 2A continuous (driving to –Batt).
A5	NENC	Negative of the Encoder
A6	CUTBACK	Speed reduction switch input #1. Active low (switch opened).
A7	BELLY	Quick inversion function input, must be connected to the belly microswitch. It is active high (+VB).

A8	NEV5/HORN OUT	Out of the electrovalves/Horn driver (driving to –Batt).
A9	NEV1	Output of the electrovalve 1 driver (driving to –Batt)
A10	+KEY	Input of the key switch signal.
A11	NEV2	Output of the electrovalve 2 driver (driving to –Batt)
A12	NMC	Output of the Line Contactor coil driver (driving to –Batt)
A13	ENC B	Traction motor encoder phase B.
A14	ENC A	Traction motor encoder phase A.
A15	CPOTTR	Accelerator potentiometer wiper.
A16	NCLTXD	Negative serial transmission pin.
A17	LIFT	Input of the lift enable switch.
A18	BOOTSTRAP	Flash memory bootstrap.
A19	HORN	Horn switch input, active high (+VB).
A20	DESCENT	Lowering request input active high.
A21	NCLRXD	Negative serial reception pin.
A22	THMOT	Traction motor thermal sensor input. The internal pull-up is a fixed 2mA (Max 5V) source current.
A23	NEV6	Output of the electrovalve 6 driver (driving to –Batt)
A24	NEVP	Negative of the proportional electrovalve.
A25	PENC	Encoder Positive Supply (+12Vdc)
A26	PCLTXD	Positive serial transmission pin.
A27	CANL	Low level CAN-BUS voltage I/O.
A28	CANH	High level CAN-BUS voltage I/O.
A29	H&S	Hard & Soft request input. Must be connected to the Hard & Soft microswitch, active high.
A30	CPOTL	Lift/Lower potentiometer wiper input.
A31	REV	Reverse switch input, active high (+VB).
A32	FW	Forward switch input, active high (+VB).
A33	NEV3	Output of the electrovalve 3 driver (driving to –Batt).
A34	NEV4	Output of the electrovalve 4 driver (driving to –Batt).
A35	IN7	Input of the switch DIGITAL INPUT #7.

## 6.2 Description of power connections

View of the power bars:

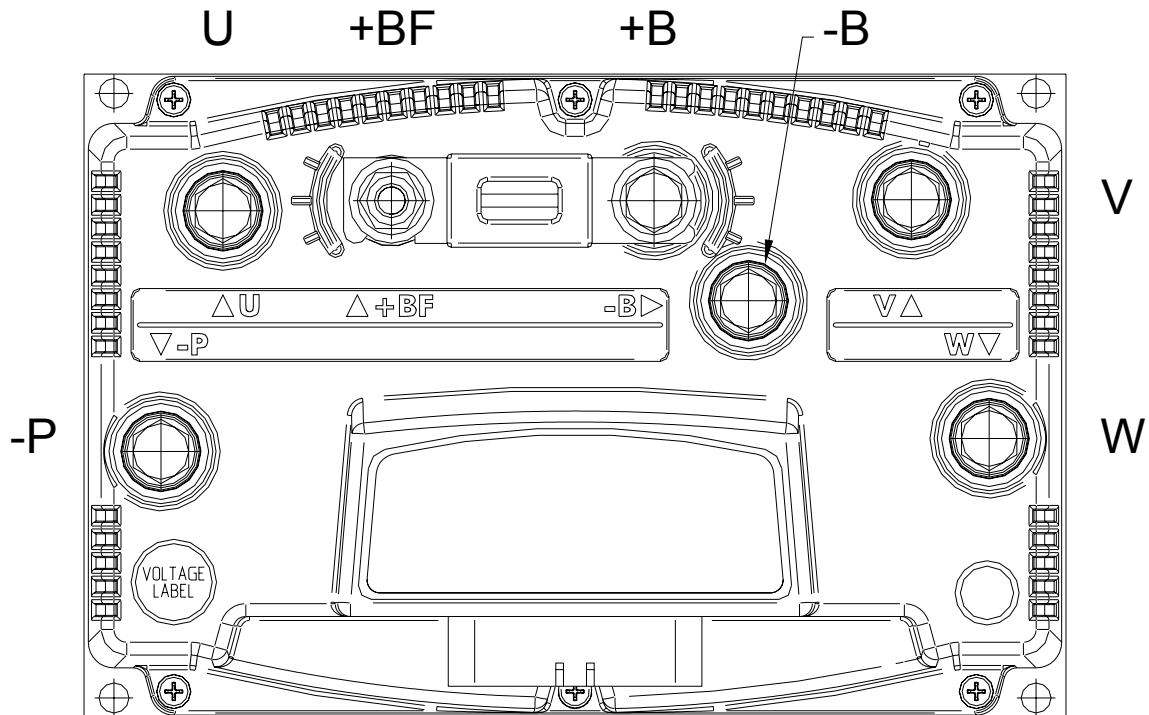

- |         |  |
|---------|--|
| -B      | Negative of the battery.   |
| +B      | Positive of the battery.   |
| +BF     | Positive of the battery, before the fuse.  |
| -P      | Output of the Pump Motor.  |
| U; V; W | Connection bars of the three motor phases; follow this sequence and the indication on the motor. |

# 7 DRAWINGS

## 7.1 Mechanical drawing

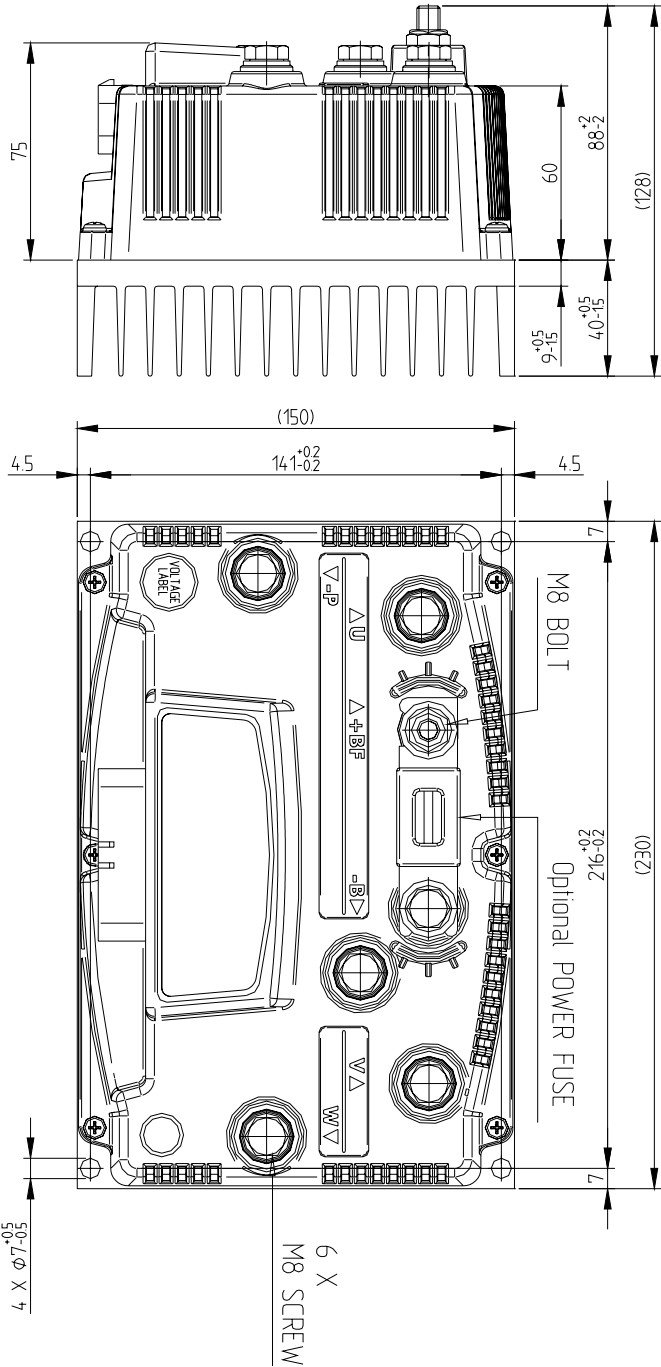

# 7.2 Connection drawing

## 7.2.1 AmpSaab version

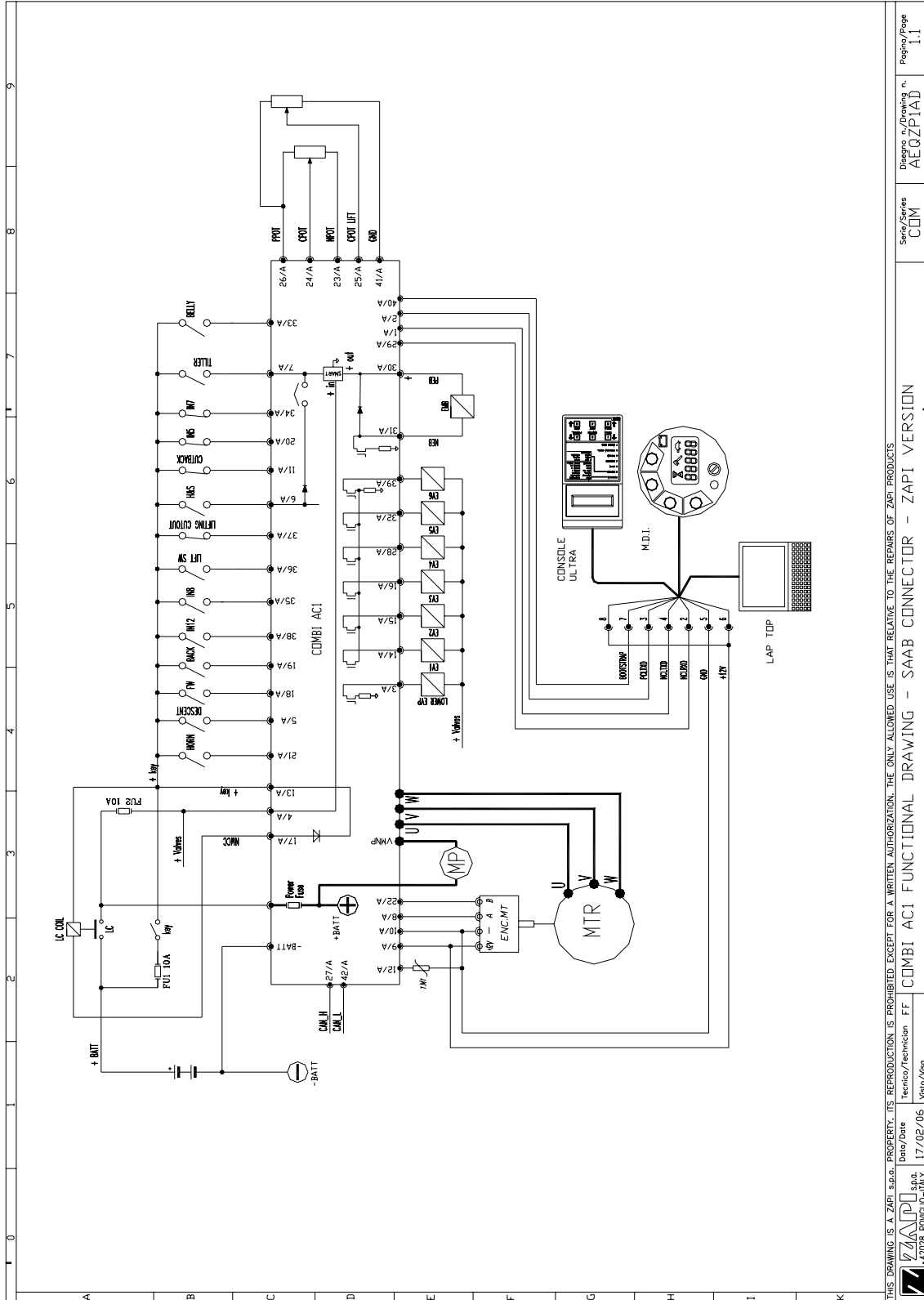

THIS DRAWING IS A ZAPI s.p.a. PROPERTY. ITS REPRODUCTION IS PROHIBITED EXCEPT FOR A WRITTEN AUTHORIZATION. THE ONLY ALLOWED USE IS THAT RELATIVE TO THE REPAIRS OF ZAPI PRODUCTS

ZAPI s.p.a.  
42028 PONGIOLO-ITALY  
Data/Date  
17/02/06  
Technic/Revision FF

COMBI AC1 FUNCTIONAL DRAWING - SAAB CONNECTOR - ZAPI VERSION

Series/Version  
COM

Disegno n./Drawing n.  
AEQZPIAD

Page/Sheet  
1/1

## 7.2.2 AmpSeal version

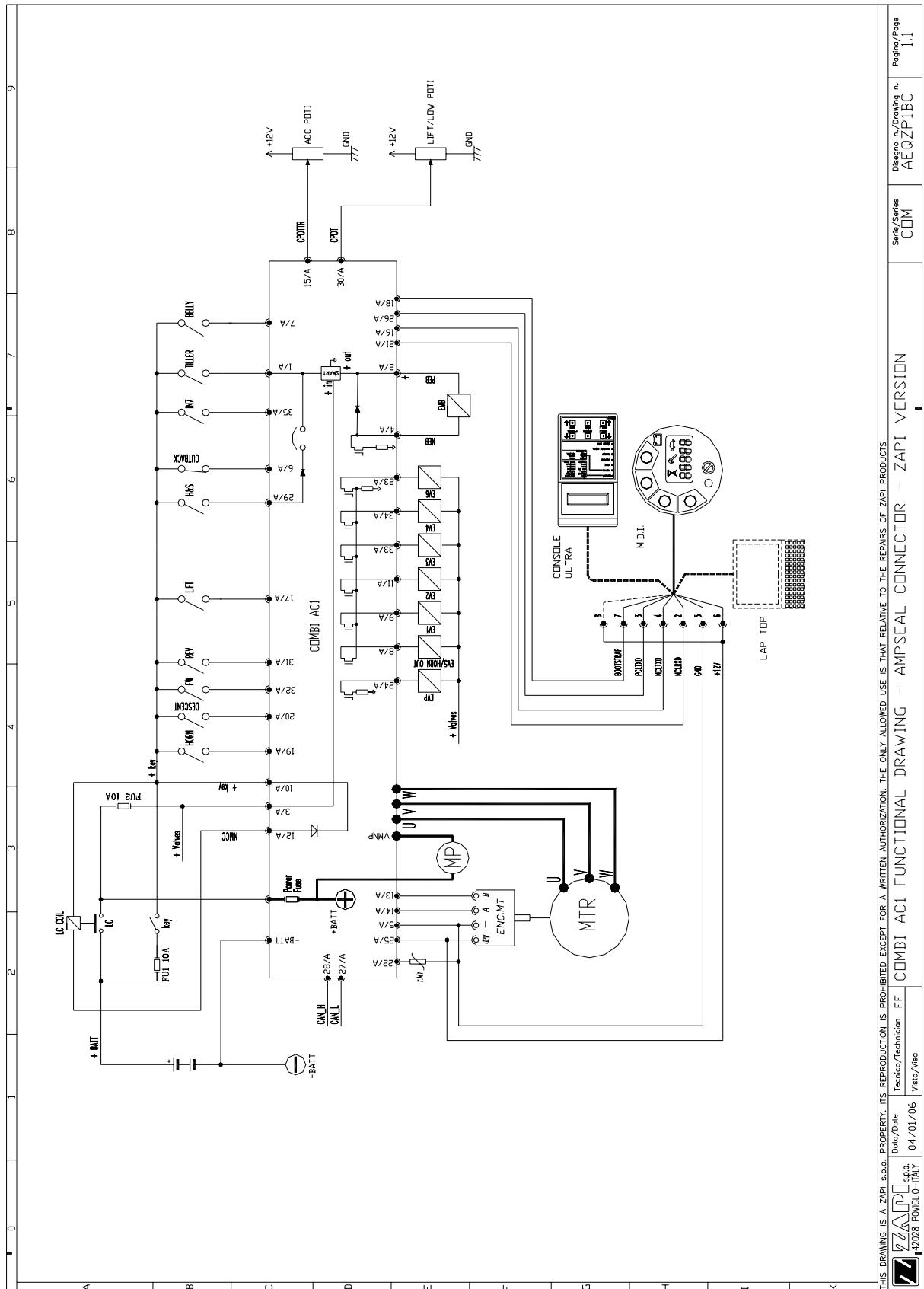

THIS DRAWING IS A ZAPI s.p.a. PROPERTY. ITS REPRODUCTION IS PROHIBITED EXCEPT FOR A WRITTEN AUTHORIZATION. THE ONLY ALLOWED USE IS THAT RELATIVE TO THE REPAIRS OF ZAPI PRODUCTS.

ZAPI s.p.a.  
 Date/Date: 04/01/06  
 Technico/Technician: FF  
 Visto/Viso:   
 Serie/Serie: COM  
 Disegno n./Drawing n.: AEQZP1BC  
 Pagina/Page: 1.1

# 8 ONE SHOT INSTALLATION PROCEDURE

This section of the manual describes the basic connection procedure. To move, the truck needs a minimum I/O outfit that it is mandatory: this minimum outfit is listed in the Steps from 1 to 8 below.

- Step1** Connect a potentiometer in the range 0.5 to 10Kohms, to modify the wished speed, between CNA#23, CNA#24, CNA#26 [AmpSaab connector]
- Step2** Connect two travel demand switches. The FWD travel demand must be connected between a battery (key) voltage and CNA#18 in AmpSaab Connector [CNA#32 in AmpSeal Connector]. The REV travel demand must be connected between a battery (key) voltage and CNA#19 in AmpSaab [CAN#31 in AmpSeal]. Only one of them can be active at the same time. They become active when connected to a key.
- Step3** Connect a tiller (or seat) switch enabling/disabling the truck motion between CNA#7 in AmpSaab [CNA#1 in AmpSeal] and a key voltage. It becomes active, enabling the motion, when closed to a key voltage.
- Step4** Connect the encoder in the motor shaft between CNA#9=VDD, CNA#10=GND, CNA#8=CHA, CNA#22=CHB in AmpSaab [CNA#25=VDD, CNA#5=GND, CNA#14=CHA, CNA#13=CHB in AmpSeal connector] . The VDD voltage may be 12V or 5V depending on a jumper inside the controller.
- Step5** Connect the plus battery voltage through a key switch at the KEY input CNA#13 [CNA#10 in AmpSeal]. This is the input for the controller supply.
- Step6** Connect the Main Contactor Coil to CNA#13 and CNA#17 in AmpSaab connector (respectively CNA#10 and CNA#12 in AmpSeal connector). The contactor must connect the battery positive to the +BATT power terminal of the COMBI AC1.
- Step7** Connect the motors and the minus battery to the corresponding power terminals of the COMBI AC1.
- Step8** Connect the Electromechanical Brake between CNA#30 and CNA#31 in the AmpSaab connector [respectively CNA#2 and CNA#4 in the AmpSeal connector]; when the tiller switch opens, the electromechanical brake gets de-energized braking the truck.

The Steps from 1 to 8 describe the installation operations that is mandatory to do in order your truck moves. Obviously the COMBI AC1 may execute a wider set of optional services as:

- 1) to handle some speed reductions requests
- 2) to handle a analog sensor inside the motor
- 3) to handle a proportional braking
- 4) to handle a proportional forks lowering valve
- 5) to handle a pump motor by a chopper.
- 6) to handle a belly switch and an Inching operative mode.
- 7) to handle a proportional input for the forks lifting/lowering.
- 8) to handle a number of on/off E-valves.



You must fill your I/O outfit with your optional functions. The optional functions are shown in the connecting drawing and described in detail inside this manual. The index may help you.

## 8.1 Sequence for Ac Inverter traction setting

This section of the manual describes the basic COMBI AC1 set-up procedure using the hand-set:

When the "Key Switch" is closed, if no alarms or errors are present, the Console Display will be showing the Standard Zapi Opening Display (Home Display).

For the setting of your truck, use the procedure below.

If you need to reply the same setting on different controller, use the Save and Restore sequence as described in the 13.1 and 13.2 paragraphs. Remember to re-cycle the Key Switch if you make any changes to the chopper's configuration.

- Step1** Fill your setting with the Options you need.
- Step2** Select the Battery Voltage.
- Step3** Check the correct installation of all wires. Use the Console's TESTER function to assist.
- Step4** Perform the accelerator signal acquisition procedure using the Console "PROGRAM VACC". Procedure is detailed on paragraph 13.3.
- Step5** Set the "MAXIMUM CURRENT" Current parameter.
- Step6** Set the ACCELERATION DELAY requirements for the machine. Test the parameters in both directions.
- Step7** Set the FREQUENCY CREEP level starting from 0.6 Hz. The machine should just move when the accelerator microswitch is closed. Increase the Level accordingly.
- Step8** Set the Speed Reductions as required. Use the parameters of the "cutback speed" family in the PARAMETER CHANGE menu to specify the reduced maximum truck speed as a percentage of the MAX SPEED FWD and MAX SPEED REV.
- Step9** RELEASE BRAKING. Operate the machine at full speed. Release the accelerator pedal. Adjust the level to your requirement. If the machine is a forklift, check the performance with and without load.
- Step10** INVERSION BRAKING. Operate the machine at 25% full speed. While travelling invert the Direction Switch. Set the suited Level of Inversion Braking. When satisfactory, operate the machine at Full Speed and repeat. If the machine is a Forklift, repeat the tests and make adjustments with and without load. The unloaded full speed condition should be the most representative condition.
- Step11** PEDAL BRAKING (If used). Operate the machine at full Speed. Release the accelerator pedal and press the Pedal Brake. Set braking level to your requirements.
- Step12** Set the parameter MAX SPEED FORW.
- Step13** Set the parameter MAX SPEED BACK (Reverse).
- Step14** Test the truck on the maximum ramp specification at full load.

**Step15** Make the choice for the truck behaviour on a slope. If the "Stop on ramp" option is ON, set the desired value of "auxiliary time" parameter.

# 9 PROGRAMMING & ADJUSTMENTS USING DIGITAL CONSOLE

## 9.1 Adjustments via console

Adjustment of Parameters and changes to the inverter’s configuration are made using the Digital Console. The Console is connected to the CNA connector of the inverter.

## 9.2 Description of console (hand set) & connection

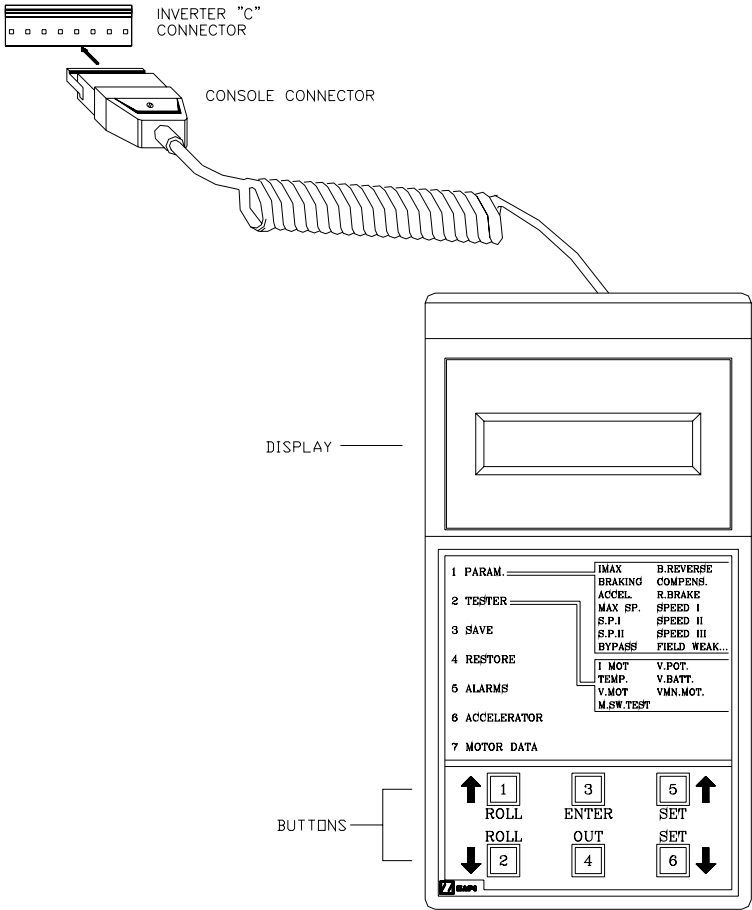

Digital consoles used to communicate with AC inverter controllers must be fitted with EPROM CK ULTRA, minimum Release Number: 3.02.

The section describes the Zapi hand set functions. Numbers inside the triangles correspond to the same number on the hand set keyboard buttons shown in the figure. The orientation of the triangle indicates the way to the next function.

## 9.3 Description of the console menu

### 9.3.1 Master: AmpSaab version

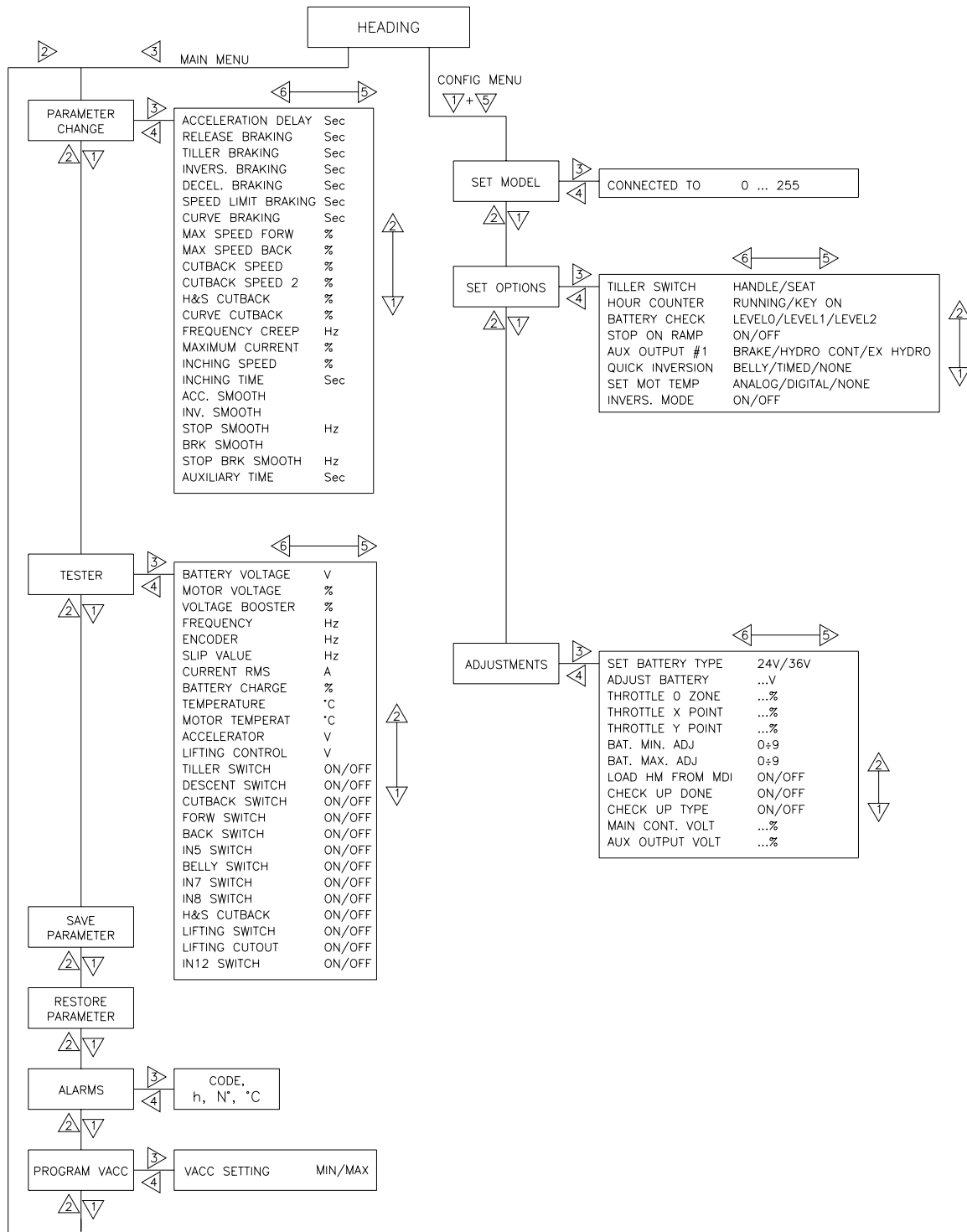

### 9.3.2 Master: AmpSeal version

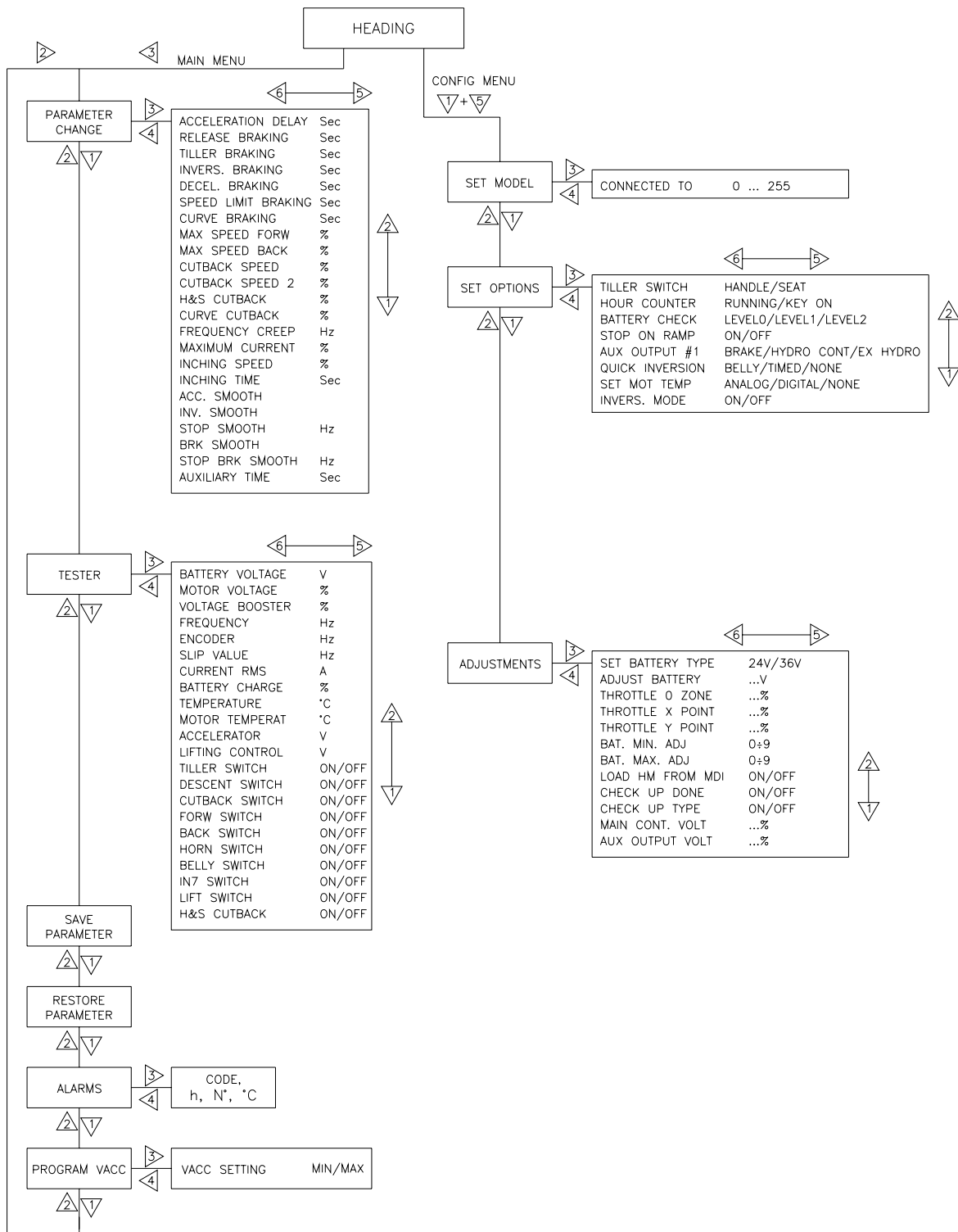

### 9.3.3 Slave: AmpSaab version

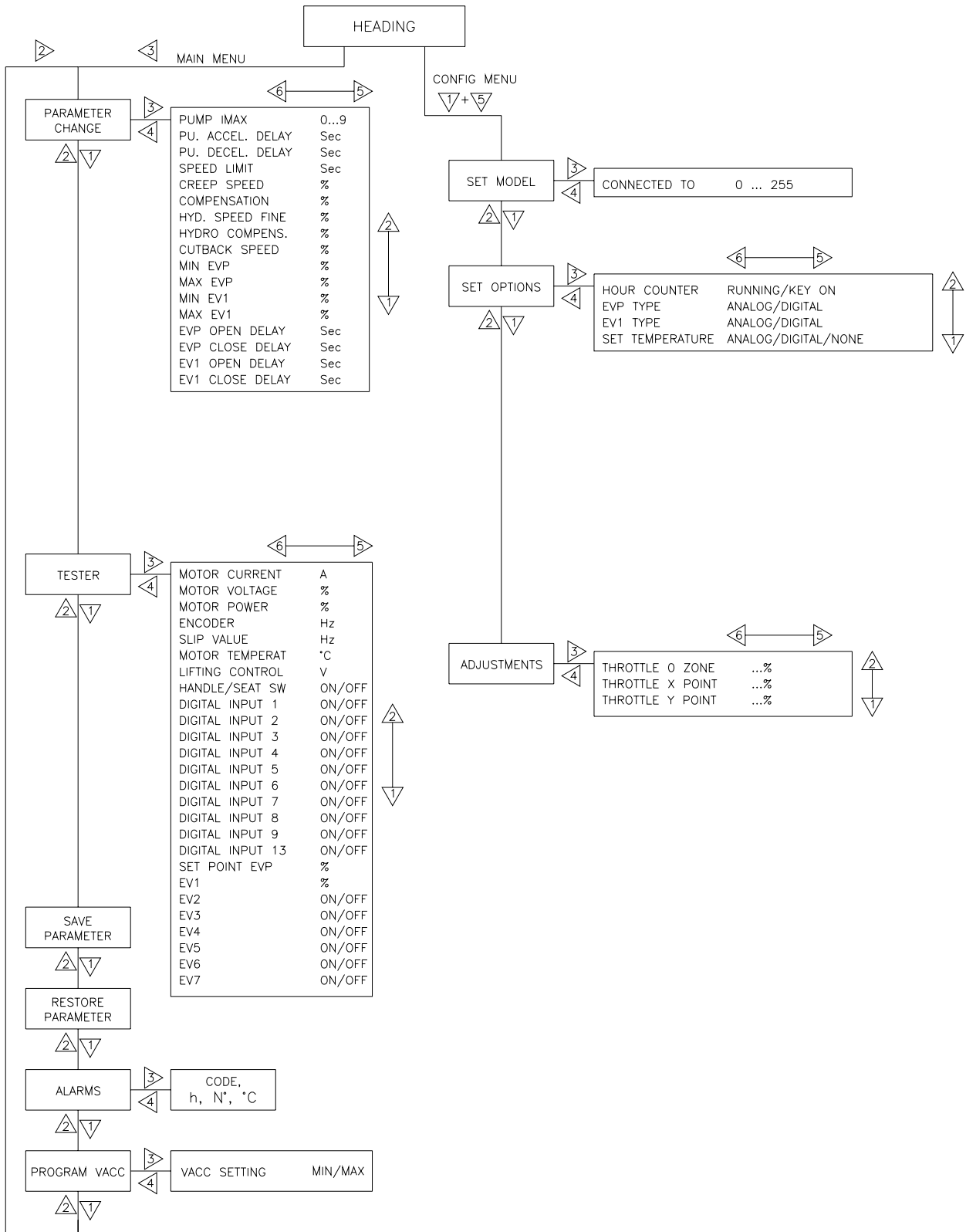

### 9.3.4 Slave: AmpSeal version

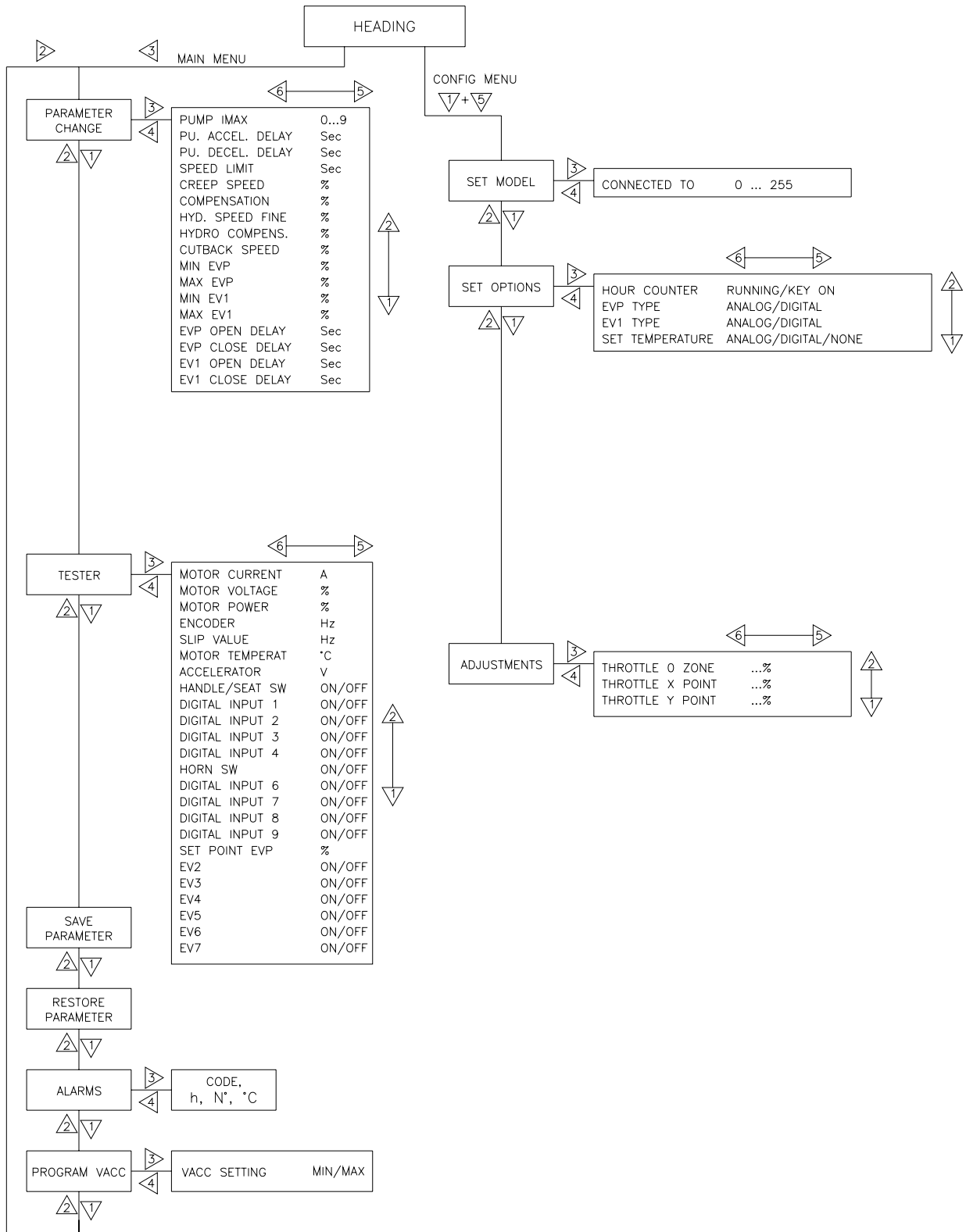

## 9.4 Function configuration (MASTER)

### 9.4.1 Config menu “SET OPTIONS” functions list

To enter the CONFIG MENU' it is necessary to push in the same time the right side top and left side top buttons. Then roll until the SET OPTION item appears on the hand set display. Push the ENTER button.

Opening Zapi Display

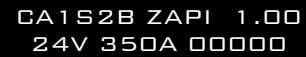

Push ROLL UP + SET UP simultaneously to enter CONFIG MENU



The Display will show : SET MODEL



Press ROLL UP or ROLL DOWN button until SET OPTIONS menu appear.

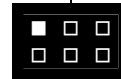

The Display will show : SET OPTIONS



Press ENTER to go in the SET OPTIONS MENU

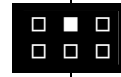

The Display will show the first OPTION



Press SET UP or SET DOWN button in order to modify the OPTION



The Display will show the new option



Press OUT to exit the menu

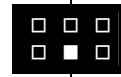

The Display will ask “ARE YOU SURE”.

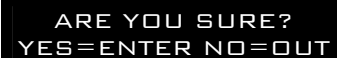

Press ENTER for YES, or OUT for No



The Display will show : SET OPTIONS



Press OUT again. Display now will show the opening Zapi menu.

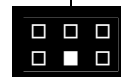

#### 1) TILLER SWITCH

This option handles the input CNA#7 in AmpSaab [CNA#1 in AmpSeal]. This input opens when the operator leaves the truck (tiller released). It is



connected to a key voltage when the operator is present. There are two levels:

- HANDLE: CNA#7 [CNA#1 in AmpSeal] is managed as tiller input (no delay when released).
- SEAT: CNA#7 [CNA#1 in AmpSeal] is managed as seat input (with a delay when released → debouncing function).

## 2) HOUR COUNTER

This option specifies the hour counter mode. It can be set one of two:

- RUNNING: The counter registers travel time only
- KEY ON: The counter registers when the "key" switch is closed (controller supplied)

## 3) BATTERY CHECK

This option specifies the handling of the low battery charge detection.

There are four levels:

- Level 0: Nothing happens, the battery charge level is calculated but is ignored, it means no action is taken when the battery is discharged.
- Level 1: BATTERY LOW alarm is raised when the battery level is calculated being less than or equal to 10% of the full charge. The BATTERY LOW alarm inhibits the Lifting function.
- Level 2: BATTERY LOW alarm is raised when the battery level is calculated being less than or equal to 10% of the full charge. The BATTERY LOW alarm reduces the maximum truck speed down to 24% of the full truck speed and it inhibits the Lifting function.
- Level 3: Equivalent to Level 1: a BATTERY LOW alarm is raised when the battery level is calculated being less than or equal to 10% of the full charge. The BATTERY LOW alarm inhibits the Lifting function.

## 4) STOP ON RAMP

Only when the encoder is present, it is possible to electrically hold the truck on a slope when the accelerator is released but the tiller is not released.

- ON: The stop on ramp feature (truck electrically hold on a ramp) is managed for a time established by AUXILIARY TIME parameter.
- OFF: the stop on ramp feature is not performed. That means the truck comes down slowly during the AUXILIARY TIME.

After this "auxiliary time", the electromechanical brake is applied and the 3-phase bridge is released; if the electromechanical brake is not present the truck comes down very slowly (see the AUX OUTPUT #1 option programming and see also 13.4).

## 5) AUX OUTPUT #1

This option handles the digital output CNA#31 in AmpSaab connector [CNA#4 in Ampseal connector]. It can be used one of four:

- BRAKE: it drives an electromechanical Brake.
- HYDROCONT: it drives the contactor for a hydraulic steering function when the direction input or brake pedal input are active or a movement of the truck is detected.
- EX.HYDRO: it drives the contactor for a hydraulic steering function when the exclusive hydro input is active
- FREE: it is not used.

The current this output can sink is up to 3Adc.

## 6) QUICK INVERSION

It can be set:

- NONE: The quick inversion function is not managed (no effect when CNA#33 switches over).
- TIMED: The quick inversion function is timed.
- BELLY: The quick inversion function is managed but not timed.

### 7) SET MOTOR TEMPERATURE

It can be set:

- ANALOG: An analog sensor for the control of the motor temperature is connected to the CNA#12 input in AmpSaab connector [CNA#22 in AmpSeal connector]
- DIGITAL: A digital (on/off) for the control of the motor temperature is connected to the CNA#12 input in AmpSaab connector [CNA#22 in Ampseal connector]
- NONE: No temperature sensor connected

### 8) INVERSION MODE

ON/OFF: This parameter sets the logic of the Quick Inversion input. If set = ON, the Quick Inversion switch is Normally Closed (function active when switch opens). If set = OFF, the Quick Inversion switch is Normally Open (function active when switch closes).

## 9.4.2 Config menu “ADJUSTMENTS” functions list

To enter the CONFIG MENU it is necessary to push in the same time the right side top and left side top buttons. Then roll until the ADJUSTMENTS item appears on the hand set display. Push the ENTER button.

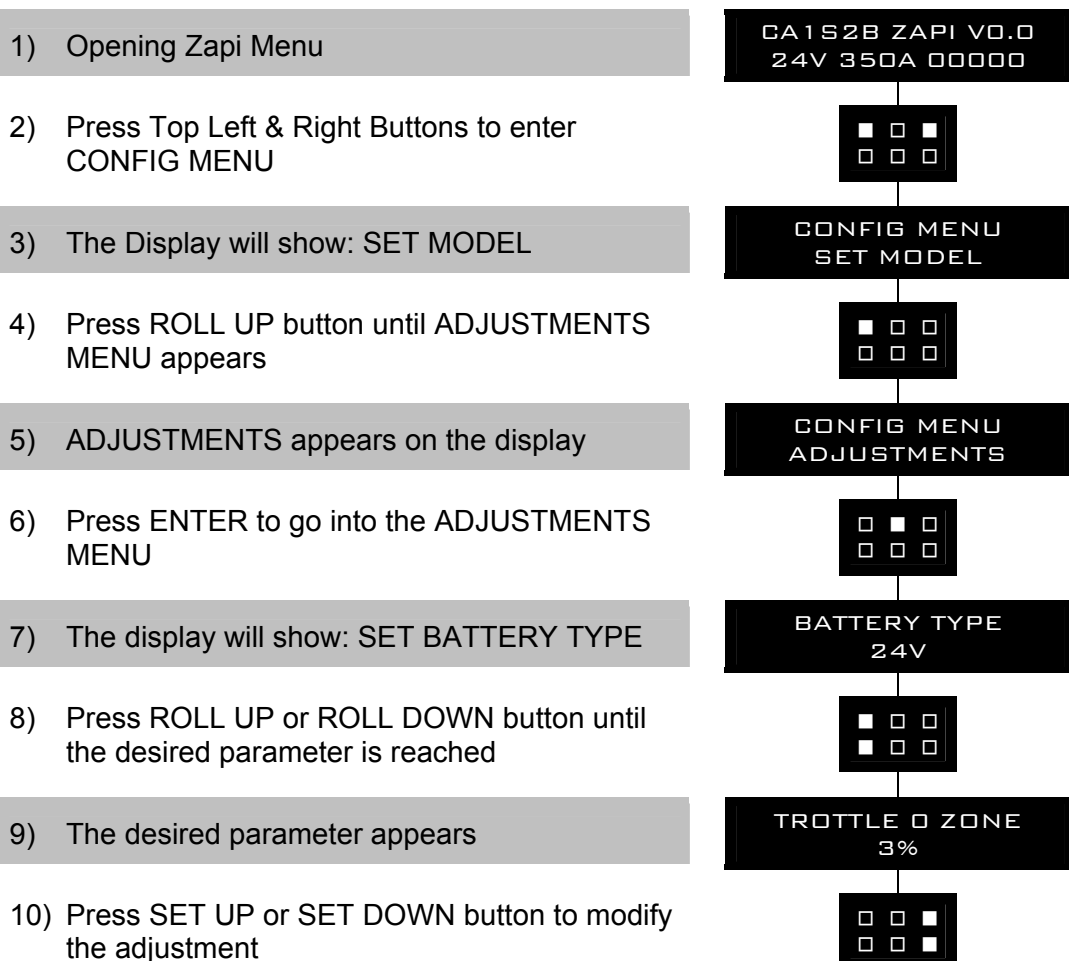

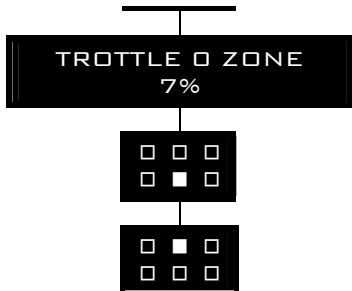

- 11) Press OUT
- 12) Press ENTER to confirm
- 13) Repeat the same from 5 to 12 points for the other adjustments

- 1) **SET BATTERY TYPE**  
Selects the nominal battery voltage.
- 2) **ADJUST BATTERY**  
Fine adjustment of the battery voltage measured by the controller.
- 3) **THROTTLE 0 ZONE**  
Establishes a deadband in the accelerator input curve.
- 4) **THROTTLE X POINT**  
This parameter, together with the THROTTLE Y POINT, changes the characteristic of the accelerator input curve : when the accelerator is depressed to X point per cent, the corresponding truck speed is Y point per cent of the Maximum truck speed. The relationship between the accelerator position and the truck speed is linear between the THROTTLE 0 ZONE and the X point and also between the X point and the maximum accelerator position but with two different slopes.
- 5) **THROTTLE Y POINT**  
This parameter, together with the THROTTLE X POINT, changes the characteristic of the accelerator input curve (see also paragraph 13.5): when the accelerator is de-pressed to X point per cent, the corresponding truck speed is Y point per cent of the Maximum truck speed. The relationship between the accelerator position and the truck speed is linear between the THROTTLE 0 ZONE and the X point and also between the X point and the maximum accelerator position but with two different slope.
- 6) **BAT. MIN ADJ.**  
Adjust the lower level of the battery charge table (Level 0 to 9).
- 7) **BAT. MAX ADJ.**  
Adjust the upper level of the battery charge table (Level 0 to 9).
- 8) **LOAD HM FROM MDI**  
When set On, the HourMeter of the Controller is transferred and recorded on the HourMeter of the Standard MDI (connected on the Serial Link).
- 9) **CHECK UP DONE**  
Turn it On when the required Maintenance service has been executed to cancel the CHECK UP NEEDED warning.
- 10) **CHECK UP TYPE**  
It specifies the handling of the CHECK UP NEEDED warning:

- NONE: No CHECK UP NEEDED warning
- OPTION#1: CHECK UP NEEDED warning shown on the hand set and MDI after 300 hours
- OPTION#2: Equal to OPTION#1 but Speed reduction after 340 hours
- OPTION#3: Equal to OPTION#2 but the truck definitively stops after 380 hours

**11) MAIN CONT. VOLTAGE**

Percentage of the total voltage of the battery applied to the main contactor coil.

**12) AUX OUTPUT VOLTAGE**

Percentage of the total voltage of the battery applied to the Eb coil.

**9.4.3 Main menu “PARAMETER CHANGE” functions list**

To enter the MAIN MENU' it is just necessary to push the ENTER button from the home display in the hand set.

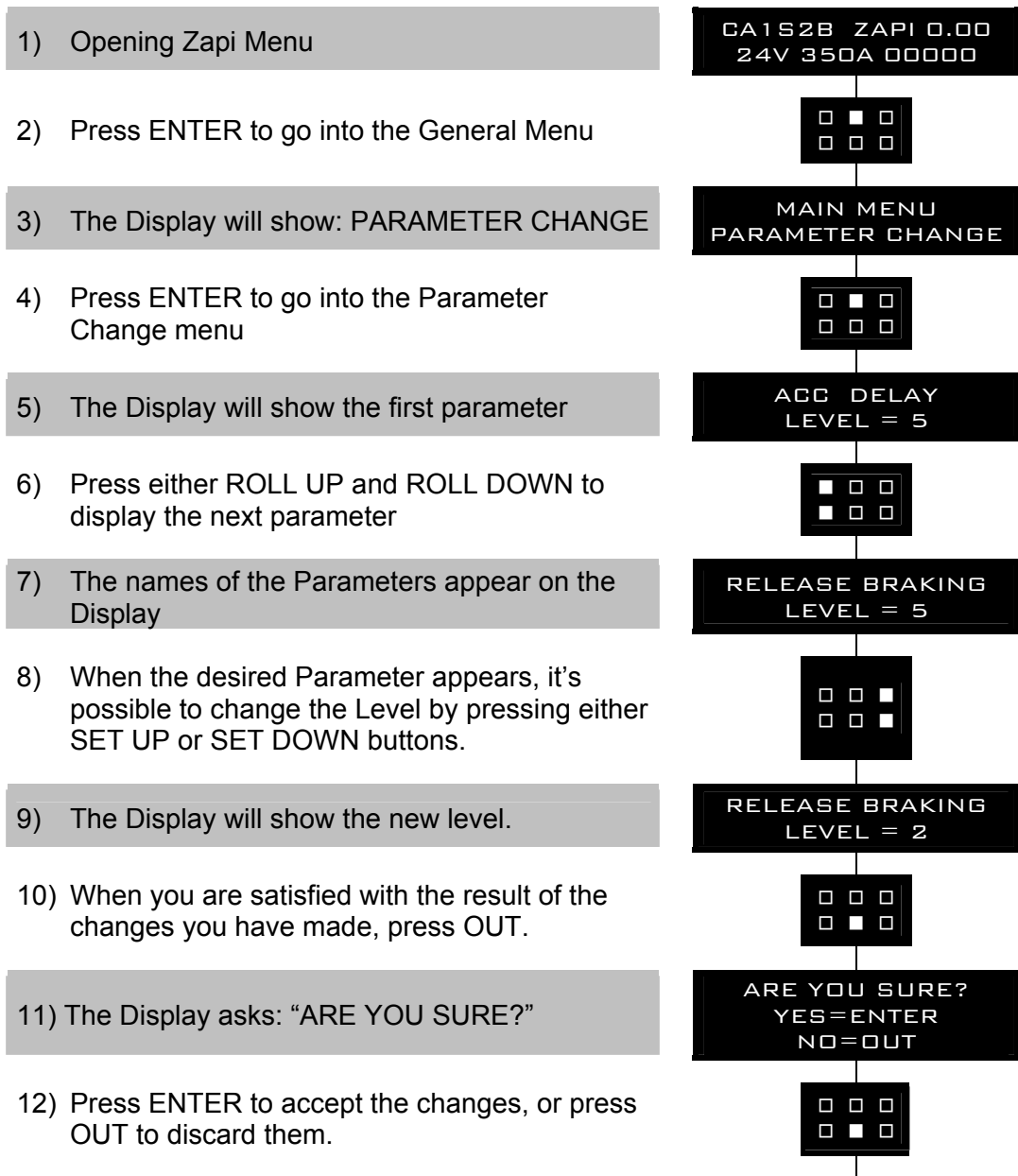

**1) ACCELER. DELAY**

Seconds. It determines the acceleration ramp. The parameter sets the time needed to speed up the traction motor from 0Hz to 100Hz.

**2) RELEASE BRAKING**

Seconds. It controls the deceleration ramp when the travel request is released. The parameter sets the time needed to decelerate the traction motor from 100Hz to 0Hz.

**3) TILLER BRAKING**

Seconds. It controls the deceleration ramp when the tiller is in braking position (released). The parameter sets the time needed to decelerate the traction motor from 100Hz to 0Hz

**4) INVERS. BRAKING**

Seconds. It controls the deceleration ramp when the direction switch is inverted during travel. The parameter sets the time needed to decelerate the traction motor from 100Hz to 0Hz.

**5) DECELERATION BRAKING**

Seconds. It controls the deceleration ramp when the accelerator has turned down but not completely released. The parameter sets the time needed to decelerate the traction motor from 100Hz to 0Hz.

**6) SPEED LIMIT BRK**

Seconds. It controls the deceleration ramp when a speed reduction has been activated. The parameter sets the time needed to decelerate the traction motor from 100Hz to 0Hz.

**7) CURVE BRAKING**

Seconds. It controls the deceleration ramp when the curve cutback input becomes active. The parameter sets the time needed to decelerate from 100Hz to 0Hz.

**8) MAX SPEED FWD**

Percentage. It determines the maximum speed in forward direction.

**9) MAX SPEED BWD**

Percentage. It determines the maximum speed in backward direction.

**10) CUTBACK SPEED 1**

Typically from 10% to 100%. It determines the percentage of the max speed applied when the cutback switch 1 (CUTBACK on CNA#11 in AmpSaab connector, CNA#6 in AmpSeal) is active. When set to 100% the speed reduction is ineffective.

**11) CUTBACK SPEED 2**

Typically from 10% to 100%. It determines the percentage of the max speed applied when the cutback switch 2 is active. When set to 100% the speed reduction is ineffective.

**12) HS CUTBACK**

Typically from 10% to 100%. It determines the percentage of the max speed applied when the Hard & Soft function (H&S switch on CNA#6 in AmpSaab connector, CNA#29 in AmpSeal connector) is active. When set to 100% the speed reduction is ineffective.

**13) CUTBACK SPEED 3**

Typically from 10% to 100%. It determines the percentage of the max speed applied when the cutback switch 3 is active. When set to 100% the speed reduction is ineffective.

**14) FREQUENCY CREEP**

Hz value. This is the minimum speed applied when the forward or reverse switch is closed, but the accelerator is at its minimum.

**15) MAXIMUM CURRENT**

Maximum level of the current (percentage of the maximum current of the controller).

**16) INCHING SPEED**

To set the speed (percentage of the maximum speed) in the inching mode.

**17) INCHING TIME**

When the inching mode is active for a period of time higher then this value, the truck automatically stops and the operator must do a new request to restart.

**18) ACCELERATION SMOOTH**

It gives a parabolic form to the acceleration ramp.

**19) INVERSION SMOOTH**

It gives a parabolic form to the acceleration ramp after a direction inversion.

**20) STOP SMOOTH**

Hz. It sets the level of frequency where the smooth effect of the acceleration parabolic form ends.

**21) BRK SMOOTH**

It gives a parabolic form to the deceleration ramp.

**22) STOP BRK SMOOTH**

Hz. It sets the level of frequency where the smooth effect of the deceleration parabolic form ends.

**23) AUXILIARY TIME**

Time units value (seconds). For the encoder version, it determines the time duration the truck is hold on the ramp if the STOP ON RAMP option is ON.

PARAMETER	UNIT	PROGRAMMED LEVEL									
		0	1	2	3	4	5	6	7	8	9
ACCELERATION DELAY	Sec.	From 0 to 10 sec., resolution of 0.1									
RELEASE BRAKING	Sec.	From 0 to 10 sec., resolution of 0.1									
TILLER BRAKING	Sec.	From 0 to 10 sec., resolution of 0.1									
INVERSION BRAKING	Sec.	From 0 to 10 sec., resolution of 0.1									
SPEED LIMIT BRAKING	Sec.	From 0 to 10 sec., resolution of 0.1									
INVERSION BRAKING	Sec.	From 0 to 10 sec., resolution of 0.1									
DECELERATION BRK.	Sec.	From 0 to 10 sec., resolution of 0.1									
SPEED LIMIT BRK.	Sec.	From 0 to 10 sec., resolution of 0.1									
CURVE BRAKING	Sec.	From 0 to 10 sec., resolution of 0.1									
MAX SPEED FW	%	From 0% to 100%, resolution of 1%									
MAX SPEED BW	%	From 0% to 100%, resolution of 1%									
CUTBACK SPEED 1	%Max Sp	From 0% to 100%, resolution of 1%									
CUTBACK SPEED 2	%Max Sp	From 0% to 100%, resolution of 1%									
H&S CUTBACK	%Max Sp	From 0% to 100%, resolution of 1%									
CUTBACK SPEED 3	%Max Sp	From 0% to 100%, resolution of 1%									
FREQUENCY CREEP	Hz	From 0.6 to 4.0 Hz, resolution of 0.1 Hz									
MAXIMUM CURRENT	%IMAX	From 0% to 100%, resolution of 1%									
INCHING SPEED	%Max Sp	From 0% to 100%, resolution of 1%									
INCHING TIME	Sec.	From 0 to 10 sec., resolution of 0.1									
STOP SMOOTH	Hz	From 3 to 20 Hz, resolution of 1Hz									
STOP BRAKE SMOOTH	Hz	From 3 to 20 Hz, resolution of 1Hz									
AUXILIARY TIME	Sec.	From 0 to 10 sec., resolution of 0.1									

#### 9.4.4 Zapi menu “SPECIAL ADJUSTMENTS” functions list

Note: the below set-up description is for skilled persons only: if you aren't, please keep your hands off. To enter this Zapi hidden menu a special procedure is required. Ask for this procedure, directly to a Zapi technician.

In the SPECIAL ADJUSTMENTS functions list, there are factory adjusted parameters only.

**1) ADJUSTMENT #01**

(Factory adjusted). % value. This is the Gain of the first Current Sensing Amplifier.

**NOTE: only Zapi technicians should change this value**

**2) ADJUSTMENT#02**

(Factory adjusted). % value. This is the Gain of the second Current Sensing Amplifier.

**NOTE: only Zapi technicians should change this value**

**3) SET TEMPERATURE**

Set the temperature offset to have the correct value reading. This is a fine calibration of the controller temperature sensor.

#### 4) **HIGH ADDRESS**

To be used to have access to special memory address.

**NOTE: only Zapi technicians should change this value**

### 9.4.5 Main menu “TESTER” functions list

The TESTER functions are a real time feedback measurements of the state of the controller/motor/command devices. It is possible to know the state (active / off) of the digital I/Os, the voltage value of the analog inputs and the state of the main variables used in the motor and hydraulics control. Enter the home page in the hand-set display and roll for the TESTER item.

#### 1) **BATTERY VOLTAGE**

Voltage value with 1 decimal digit. Battery voltage value measured at the key on.

#### 2) **MOTOR VOLTAGE**

Percentage value. It is the voltage generated by the inverter expressed in per cent of the actual battery voltage. 100% means the sine wave width is close to the actual battery voltage; 0% means the sine wave width is null.

#### 3) **VOLTAGE BOOSTER**

Percentage value. It is the booster contribute to the voltage really supplied to the motor expressed in per cent of the actual battery voltage. (Note: when DC\_LINK COMPENSATION is set ON, the VOLTAGE BOOSTER reading will not match perfectly the booster setting because this latest one is calculated respect to the nominal battery voltage; VOLTAGE BOOSTER is expressed respect to the actual battery voltage).

#### 4) **FREQUENCY**

Hz value. This is the frequency of the sine waves the inverter is supplying.

#### 5) **ENCODER**

Hz value. This is the speed of the motor measured with the encoder and expressed in the same unit of the FREQUENCY reading.

#### 6) **SLIP VALUE**

Hz value. This is the slip between the frequency and the speed of the motor (SLIP VALUE = FREQUENCY-ENCODER).

#### 7) **CURRENT RMS**

Ampere value. Root Mean Square value of the line current in the motor.

#### 8) **BATTERY CHARGE**

Percentage value. It supplies the residual charge of the battery as a percentage of the full charge level.

#### 9) **TEMPERATURE**

°C value. This is the temperature of the inverter base plate. This temperature is used for the HIGH TEMPERATURE alarm detection.

#### 10) **MOTOR TEMPERATURE**

°C value. This is the temperature of the motor windings picked up with an



analog sensor inside the motor. Normally this sensor is a PTC Philips KTY84-130. This temperature is used only to raise a warning in the hand set when the motor temperature overtakes the MOTOR OVERTEMP setting.

#### **11) ACCELERATOR**

From 0.0V to 5.0V. The voltage on the wiper of the accelerator (CPOT on CNA#24 in AmpSaab version, CNA#15 in AmpSeal version) is halved inside the controller and then recorded on this reading. That means the actual wiper voltage is in the range 0 to 10V meanwhile the corresponding ACCELERATOR reading is in the range 0.0 to 5.0Vdc.

#### **12) LIFTING CONTROL**

From 0.0 to 5.0V. The voltage on the wiper of the accelerator (CPOTLIFT on CNA#25 [AmpSaab connector], CNA#30 [AmpSeal connector]) is halved inside the controller and then recorded on this reading. That means the actual wiper voltage is in the range 0 to 10V meanwhile the corresponding ACCELERATOR reading is in the range 0.0 to 5.0Vdc

#### **13) TILLER SWITCH**

ON/OFF. This is the level of the digital input CNA#6 in AmpSaab connector [CNA#29 in AmpSeal connector] for the Hard & Soft request. With the H&S service is possible to turn the truck moving (at reduced speed) only by acting the H&S switch, and the accelerator, without to let down the tiller :

- ON +VB = When it is closed to a battery (key) voltage, the H&S request is Active.
- OFF GND = When it is not connected to a battery (key) voltage (or it is connected to GND), the H&S request is not active.

#### **14) DESCENT SWITCH**

ON/OFF. This is the level of the digital input CNA#5 in AmpSaab connector [CNA#20 in AmpSeal connector] for the Lowering request:

- ON +VB = When it is closed to a battery (key) voltage, the Lowering request is Active.
- OFF GND =When it is not connected to a battery (key) voltage (or it is connected to GND), the Lowering request is not active.

#### **15) CUTBACK SWITCH**

ON/OFF. This is the level of the digital input CNA#11 in AmpSaab connector [CNA#6 in AmpSeal connector]:

- ON GND = When it is not closed to a battery (key) voltage (or connected to GND) the SR#1 request is active.
- OFF +VB = When it is closed to a battery (key) voltage the SR#1 request is not active.

#### **16) FORWARD SWITCH**

ON/OFF. This is the level of the digital input CNA#18 in AmpSaab connector [CNA#32 in AmpSeal connector] for the forward travel demand:

- ON +VB = When it is closed to a battery (key) voltage, the Forward Travel demand is Active.
- OFF GND =When it is not connected to a battery (key) voltage (or it is connected to GND), the Forward Travel demand is not active.

#### **17) BACKWARD SWITCH**

ON/OFF. This is the level of the digital input CNA#19 in AmpSaab connector [CNA#31 in Ampseal connector] for the backward travel demand:

- ON +VB = When it is closed to a battery (key) voltage, the Backward Travel demand is Active.
- OFF GND = When it is not connected to a battery (key) voltage (or it is connected to GND), the Backward Travel demand is not active.

#### 18) IN 5 SWITCH

ON/OFF. This is the level of the digital input#5 CNA#20 in AmpSaab connector [CNA#19 in AmpSeal connector]:

- ON +VB = When it is closed to a battery (key) voltage the digital input#5 request is active.
- OFF GND = When it is not closed to a battery (key) voltage (or connected to GND) the digital input#5 request is not active.

#### 19) BELLY SWITCH

ON/OFF. This is the level of the digital input CNA#33 in AmpSaab connector [CNA#7 in AmpSeal connector] ( belly button):

- ON +VB = When it is closed to a battery (key) voltage, the request of the Belly (to stop the movement) is active.
- OFF GND= When it is not connected to a battery (key) voltage (or it is connected to GND), the Belly request is not active.

#### 20) IN 7 SWITCH

ON/OFF. This is the level of the digital input#7 CNA#34 in AmpSaab connector [CNA#35 in AmpSeal connector] :

- ON +VB = When it is closed to a battery (key) voltage the voltage the digital input#7 request is active.
- OFF GND = When it is not closed to a battery (key) voltage (or connected to GND) the voltage the digital input#7 request is not active.

#### 21) IN 8 SWITCH

Only for AmpSaab version. ON/OFF. This is the level of the digital input#8 CNA#35 in AmpSaab connector:

- ON +VB = When it is closed to a battery (key) voltage the digital input#8 is active.
- OFF GND = When it is not closed to a battery (key) voltage (or it is connected to GND) the digital input#8 is not active.

#### 22) H&S CUTBACK

ON/OFF. This is the level of the digital input CNA#6 in AmpSaab connector [CNA#29 in AmpSeal connector] for the Hard & Soft request. With the H&S service is possible to turn the truck moving (at reduced speed) only by acting the H&S switch, and the accelerator, without to let down the tiller :

- ON +VB = When it is closed to a battery (key) voltage, the H&S request is Active.
- OFF GND = When it is not connected to a battery (key) voltage (or it is connected to GND), the H&S request is not active.

#### 23) LIFTING SWITCH

ON/OFF. This is the level of the digital input CNA#36 (in AmpSaab connector, CNA#17 in AmpSeal connector) for the lifting request:

- ON +VB = When is closed to a battery (key) voltage, the Lifting request is Active.
- OFF GND = When is not connected to a battery (key) voltage (or it is connected to GND), the Lifting request is not active.

#### 24) LIFTING CUTOUT

ON/OFF. This is the level of the CNA#37 digital input (only in AmpSaab connector):

- ON GND = When CNA#37 is not closed to a battery (key) voltage (or connected to GND) the Lift Stop is active.
- OFF +VB = When CNA#37 is closed to a battery (key) voltage the Lift Stop is not active.

#### **25) IN12 SWITCH**

ON/OFF. This is the level of the digital input#12 CNA#38 (only in AmpSaab connector):

- ON +VB = When it is closed to a battery (key) voltage the digital input#12 is active.
- OFF GND = When it is not closed to a battery (key) voltage (or it is connected to GND) the digital input#12 is not active.

---

## **9.5 Function configuration (SLAVE)**

### **9.5.1 Config menu “SET OPTIONS” functions list**

#### **1) HOUR COUNTER**

Same function of the hour counter option of the Master. When set RUNNING, the hourcounter counts the working time of the pump motor and of the lowering EVP.

#### **2) EVP TYPE**

Analog/digital: defines the type of the EVP electrovalve, current controlled:  
Analog: the related output manages a proportional valve, current controlled  
Digital: the related output manages an on/off valve

#### **3) EV1 TYPE**

Analog/digital: defines the type of the EV1 electrovalve, voltage controlled:  
Analog: the related output manages a proportional valve, with a voltage controlled method  
Digital: the related output manages an on/off valve.

#### **4) SET TEMPERATURE**

NONE/ANALOG/DIGITAL: set the type of sensor for the measurement of the pump motor temperature.

### **9.5.2 Config menu “ADJUSTMENTS” functions list**

#### **1) THROTTLE 0 POINT**

Establishes a deadband in the lift/lower accelerator (or, in general, the potentiometer used to command the speed of the motor connected to the slave) input curve.

#### **2) THROTTLE X POINT**

This parameter, together with the THROTTLE Y POINT, changes the characteristic of the lift/lower accelerator input curve : when the accelerator is de-pressed to X point per cent, the corresponding truck speed is Y point per cent of the Maximum truck speed. The relationship between the accelerator position and the truck speed is linear between the THROTTLE 0 ZONE and the X point and also between the X point and the maximum accelerator position but with two different slope.

### 3) **THROTTLE Y POINT**

This parameter, together with the THROTTLE X POINT, changes the characteristic of the lift/lower accelerator input curve (see also paragraph 13.5): when the accelerator is de-pressed to X point per cent, the corresponding truck speed is Y point per cent of the Maximum truck speed. The relationship between the accelerator position and the truck speed is linear between the THROTTLE 0 ZONE and the X point and also between the X point and the maximum accelerator position but with two different slope.

## 9.5.3 Config menu “PARAMETER CHANGE” functions list

When the slave controls pump motor and pump functions, we have these parameters:

### 1) **PUMP IMAX**

Level 0 to 9. Set the maximum current for the pump motor.

### 2) **PUMP ACCELERATION DELAY**

In seconds. Set the acceleration ramp for the pump motor.

### 3) **PUMP DECELERATION DELAY**

In seconds. Set the deceleration ramp for the pump motor.

### 4) **SPEED LIMIT**

Percentage. It limits the maximum speed of the lifting function. Percentage of the maximum voltage applied to the pump motor.

### 5) **CREEP SPEED**

Percentage. It sets the minimum speed (percentage of voltage applied) for the pump motor. Percentage of the maximum voltage applied to the pump motor.

### 6) **COMPENSATION**

From 0% to 100% This parameter sets the voltage compensation ( $\Delta V$ ) applied to the motor when the proportional lifting function is active. The value of this  $\Delta V$  applied to the motor is a function of the motor current. Aim of this function is to reduce, as far as possible, the speed difference between the truck loaded and unloaded.

### 7) **HYD SPEED FINE**

Fine adjustment of the pump motor steering function speed.

### 8) **HYDRO COMPENSATION**

Adjustment of the compensation function when the pump motor steering function is active.

### 9) **CUTBACK SPEED**

Percentage of the maximum speed. It defines the reduction of the pump motor speed when the cutback is triggered.

**10) MIN EVP**

0 to 100. This parameter determines the minimum voltage applied on the EVP when the position of the potentiometer is at the minimum. This parameter is not effective if the EVP is programmed like a On/Off valve.

**11) MAX EVP**

0 to 100. This parameter determines the maximum voltage applied on the EVP when the position of the potentiometer is at the maximum. If the EVP is programmed like a On/Off valve this parameter determines the fixed voltage applied on the electrovalve coil.

**12) EVP OPEN DELAY**

In seconds. It defines the opening ramp of the evp electrovalve when related output is set as Analog (refer to Set Option menu).

**13) EVP CLOSE DELAY**

In seconds. It defines the closing ramp of the evp electrovalve when related output is set as Analog (refer to Set Option menu).

**14) EV1 OPEN DELAY**

In seconds. It defines the opening ramp of the evp1 electrovalve, when related output is set as Analog (refer to Set Option menu).

**15) EV1 CLOSE DELAY**

In seconds. It defines the closing ramp of the evp1 electrovalve, when related output is set as Analog (refer to Set Option menu).

PARAMETER	UNIT	PROGRAMMED LEVEL									
		0	1	2	3	4	5	6	7	8	9
PUMP IMAX	%	From 50% to 100% of IMAX, resolution of 5%									
PUMP ACC. DELAY	Sec.	From 0 to 10 sec., resolution of 0.1									
PUMP DEC. DELAY	Sec.	From 0 to 10 sec., resolution of 0.1									
SPEED LIMIT	%	From 0% to 100%, resolution of 1%									
CREEP SPEED	%	From 0% to 100%, resolution of 1%									
COMPENSATION	%	From 0% to 100%, resolution of 1%									
HYD SPEED FINE	%	From 0% to 100%, resolution of 1%									
HYDRO COMPENSATION	%	From 0% to 100%, resolution of 1%									
CUTBACK SPEED	%	From 0% to 100%, resolution of 1%									
MIN EVP	%	From 0% to 100%, resolution of 0.1%									
MAX EVP	%	From 0% to 100%, resolution of 0.1%									
EVP OPEN DELAY	Sec.	From 0 to 25.5 sec., resolution of 0.1									
EVP CLOSE DELAY	Sec.	From 0 to 25.5 sec., resolution of 0.1									
EV1 OPEN DELAY	Sec.	From 0 to 25.5 sec., resolution of 0.1									
EV1 CLOSE DELAY	Sec.	From 0 to 25.5 sec., resolution of 0.1									

## 9.5.4 Config menu “SPECIAL ADJUSTMENTS ” functions list

- 1) **ADJUSTMENT #1**  
(Factory adjusted). % value. This is the Gain of the Pump chopper Current Sensing Amplifier.  
**NOTE: only Zapi technicians should change this value.**
- 2) **SET CURRENT**  
set the current limit for the measurement in the TESTER menu.
- 3) **AUX OUTPUT #1**  
Debug function.
- 4) **AUX OUTPUT #2**  
Debug function.

## 9.5.5 Config menu “TESTER ” functions list

- 1) **MOTOR CURRENT**  
Ampere. It is the current in the motor controlled by the slave of combiac1.
- 2) **MOTOR VOLTAGE**  
It is the voltage of the motor controlled by the slave of combiac1, expressed in percentage of the maximum voltage.
- 3) **MOTOR POWER**  
Watt. Estimate value of the traction motor power. This parameter is used by Slave  $\mu$ C in order to carry out safety checks on traction functions (managed by Master  $\mu$ C).
- 4) **ENCODER**  
Hz. Speed of the traction motor. This parameter is used by Slave  $\mu$ C in order to carry out safety checks on traction functions (managed by Master  $\mu$ C)
- 5) **SLIP**  
Hz. Estimate of traction motor slip. This parameter is used by Slave  $\mu$ C in order to carry out safety checks on traction functions (managed by Master  $\mu$ C).
- 6) **MOTOR TEMPERATURE**  
 $^{\circ}$ C. Measure of the pump motor temperature.
- 7) **LIFTING CONTROL**  
Volt. Measure of the lift/lower potentiometer input (signal CPOTLIFT: CNA#25 in AmpSaab connector, CNA#30 in AmpSeal connector).
- 8) **HANDLE/SEAT SW**  
On/off: it determines if the TILLER input is active or not (CNA#7 in AmpSaab, CNA#20 in AmpSeal).
- 9) **DIGITAL INPUT 1**  
On/off : it determines if the input 1 is active or not (Lowering switch, CNA#5 in AmpSaab, CNA#20 in AmpSeal).
- 10) **DIGITAL INPUT 2**  
On/off : it determines if the input 2 is active or not (Speed Reduction#1 switch, CNA#11 in AmpSaab, CNA#6 in AmpSeal).
- 11) **DIGITAL INPUT 3**  
On/off : it determines if the input 3 is active or not (Forward switch, CNA#18 in AmpSaab, CNA#32 in AmpSeal).
- 12) **DIGITAL INPUT 4**  
On/off : it determines if the input 4 is active or not (Reverse switch, CNA#19 in AmpSaab, CNA#31 in AmpSeal).
- 13) **DIGITAL INPUT 5**  
On/off : it determines if the input 5 is active or not (CNA#20 in AmpSaab, CNA#19 in AmpSeal).

**14) DIGITAL INPUT 6**

On/off : it determines if the input 6 is active or not (Belly switch, CNA#33 in AmpSaab, CNA#7 in AmpSeal).

**15) DIGITAL INPUT 7**

On/off : it determines if the input 7 is active or not (Speed Reduction #3 switch, CNA#34 in AmpSaab, CNA#35 in AmpSeal).

**16) DIGITAL INPUT 8**

On/off : it determines if the input 8 is active or not (Deadman switch, CNA#35 in AmpSaab, CNA#17 in AmpSeal).

**17) DIGITAL INPUT 9**

On/off : it determines if the input 9 is active or not (H&S switch, CNA#6 in AmpSaab, CNA#29 in AmpSeal).

**18) DIGITAL INPUT 13**

On/off : it determines if the input 13 is active or not (Horn switch, CNA#21 in AmpSaab).

**19) SET POINT EVP**

This parameter shows the setpoint of EVP valve.

**20) EV1**

Show the percentage of voltage applied to Ev1 valve.

**21) EV2**

On/Off: determines if the valve is open or closed.

**22) EV3**

On/off: determines if the valve is open or closed.

**23) EV4**

On/off: determines if the valve is open or closed.

**24) EV5**

On/off: determines if the valve is open or closed.

**25) EV6**

On/off: determines if the valve is open or closed.

**26) EV7**

On/off: determines if the valve is open or closed.



# 10 OTHER FUNCTIONS

## 10.1 Description of console “SAVE” function

The SAVE function allows the operator to transmit the Parameter values and Configuration data of the controller into the Console memory. It is possible to load 64 different programmes.

The information saved in the Console memory can then be reloaded into another controller using the RESTORE function.

The data that is available via the SAVE function are listed here below:

- All Parameter Values (PARAMETER CHANGE).
- Options (SET. OPTIONS).
- The Level of the Battery (ADJUST BATTERY).

Flow Chart showing how to use the SAVE function of the Digital Console.

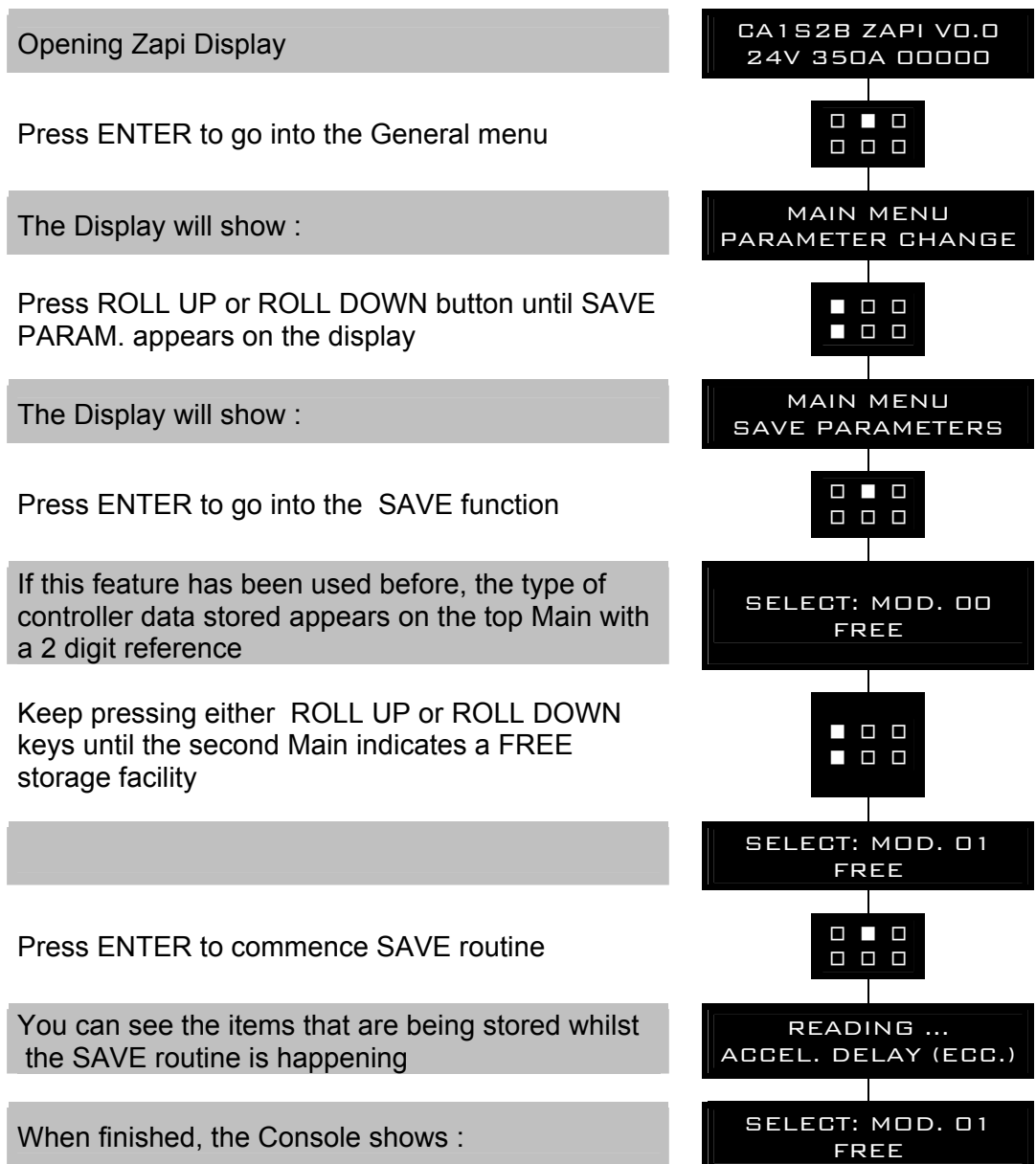

Press OUT to return to the Opening Zapi Display



NOTE: in reality the SAVE and RESTORE function requires the Windows PC-Console.

## 10.2 Description of console “RESTORE” function

The RESTORE PARAM function allows transfer of the Console’s stored data into the memory of the controller. This is achieved in a fast and easy way using the method previously used with the SAVE PARAM. function.

The data that is available on the RESTORE PARAM. Function are listed here below:

- All Parameter Values (PARAMETER CHANGE).
- Options (SET OPTIONS)
- The level of the Battery (ADJUST BATTERY)

ATTENTION: When the RESTORE operation is made, all data in the controller memory will be written over and replaced with data being restored.

Flow Chart showing how to use the RESTORE function of the Digital Console.

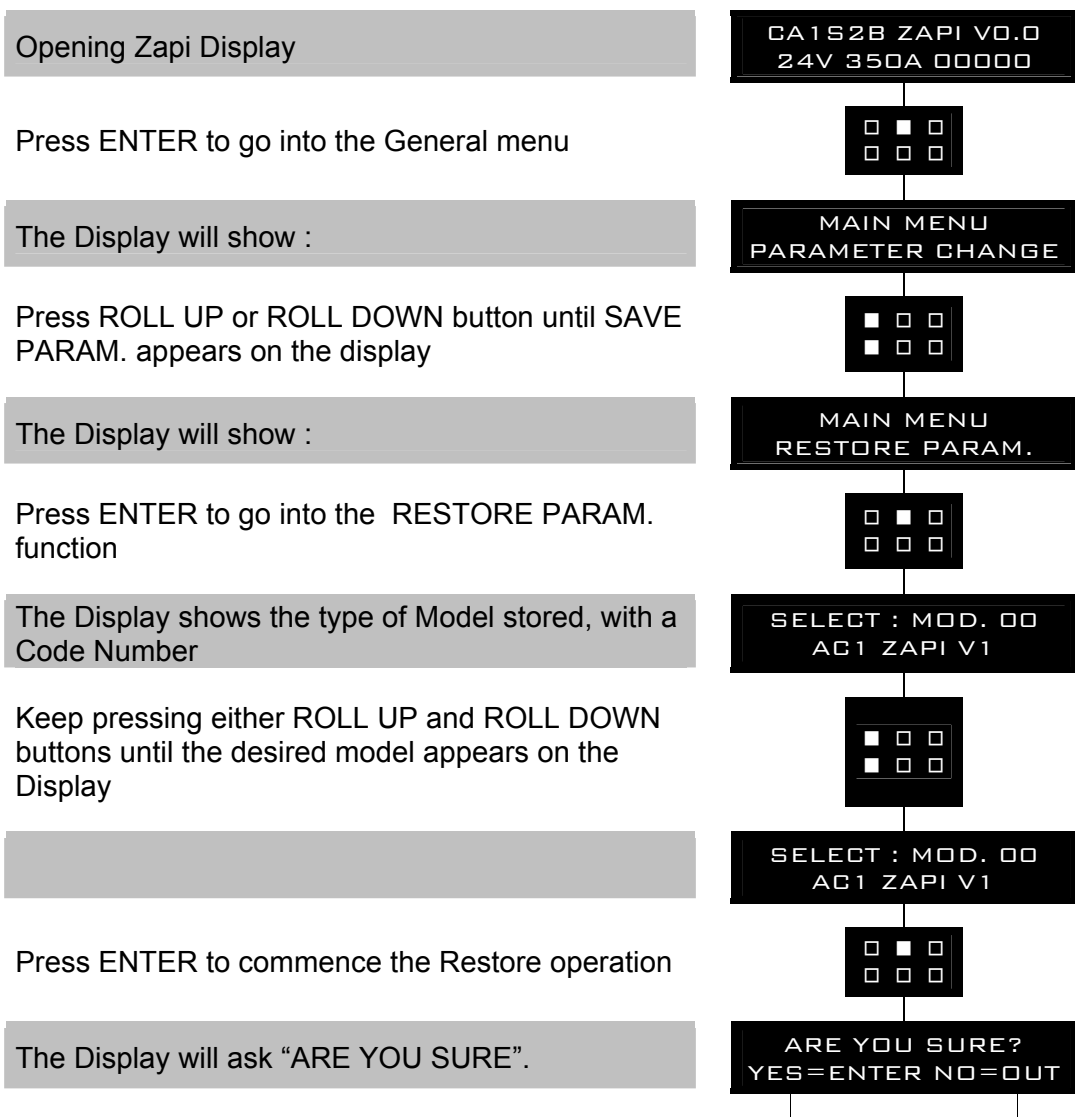

Press ENTER for YES, or OUT for No

You can see the items that are being stored in the chopper memory whilst the RESTORE routine is happening

When finished, the Console shows :

Press OUT to return to the Opening Zapi Display

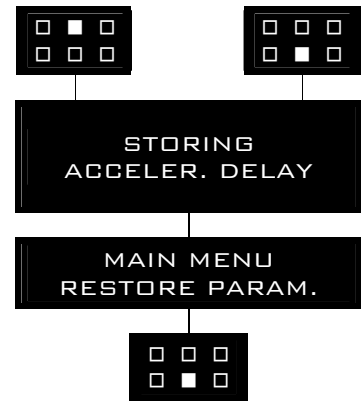

NOTE: in reality the SAVE and RESTORE function requires the Windows PC-Console.

### 10.3 Description of console “PROGRAM VACC” function

This enables adjustment of the minimum and maximum useful signal level, in either direction. This function is unique when it is necessary to compensate for asymmetry with the mechanical elements associated with the potentiometer, especially relating to the minimum level.

The two graphs show the output voltage from a non-calibrated potentiometer with respect to the mechanical “zero” of the control lever. MI and MA indicate the point where the direction switches close. 0 represents the mechanical zero of the rotation.

The Left Hand graph shows the relationship of the motor voltage without signal acquisition being made. The Right Hand Graph shows the same relationship after signal acquisition of the potentiometer.

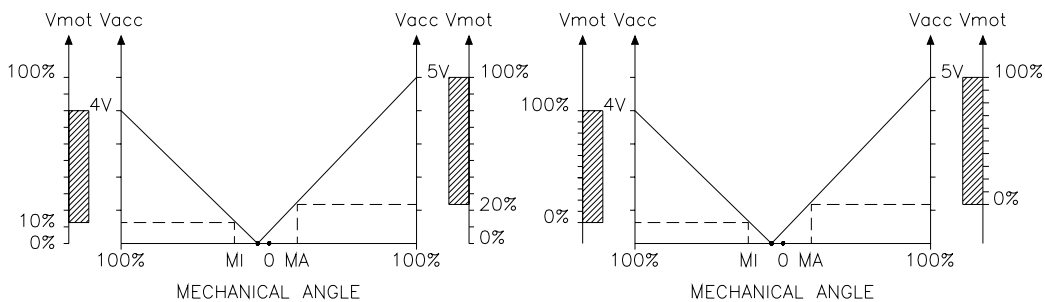

This function looks for and remembers the minimum and maximum potentiometer wiper voltage over the full mechanical range of the pedal. It enables compensation for non symmetry of the mechanical system between directions.

The operation is performed by operating the pedal after entering the PROGRAM VACC function.

Flow Chart showing how to use the PROGRAM VACC function of the Digital Console.

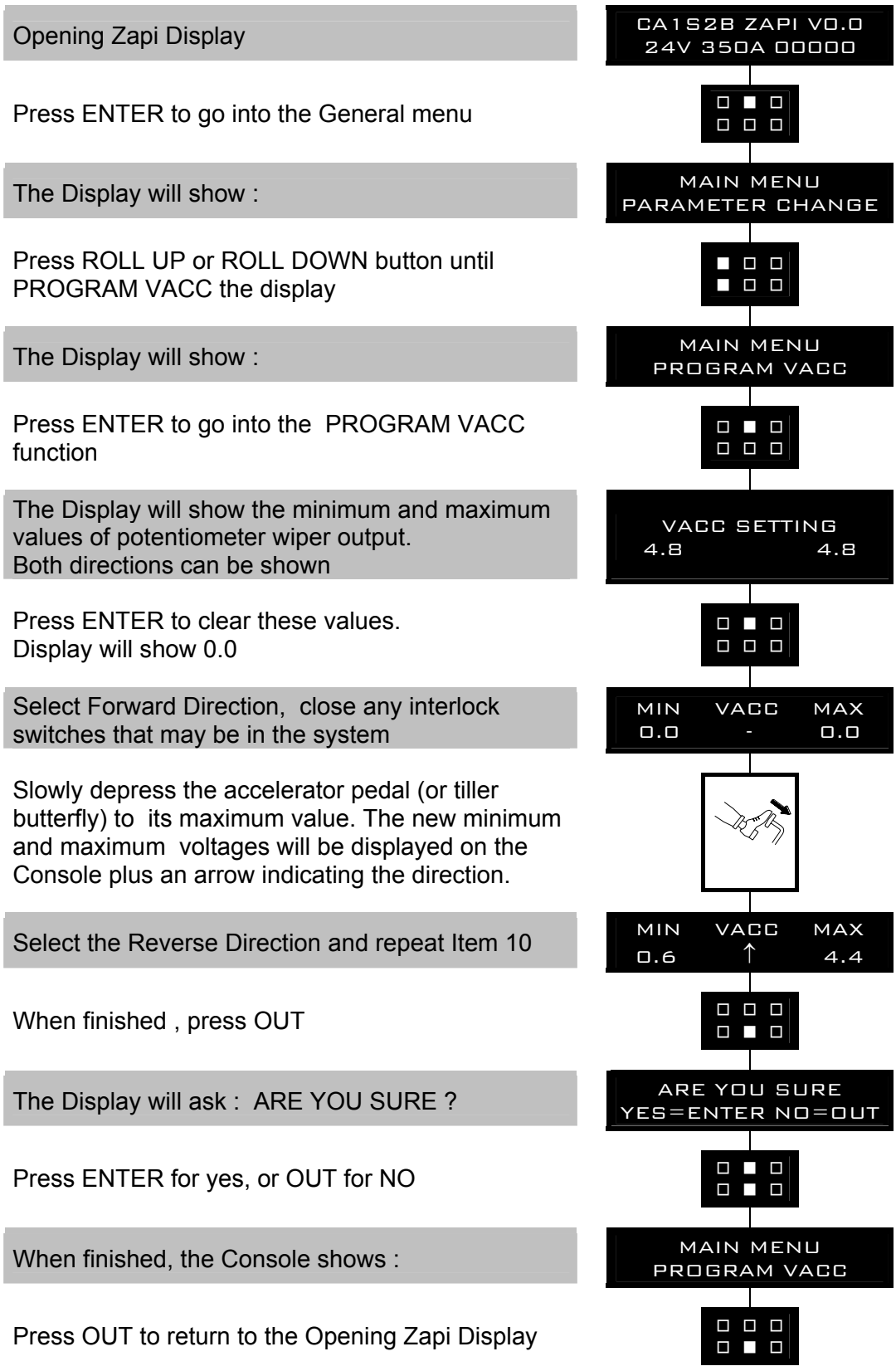

## 10.4 Description of the throttle regulation

This regulation applies a not linear relationship between the position of the accelerator and the speed of the truck. The main goal is to increase the resolution for the speed modulation when the truck is slowly moving.

Three adjustments are used for the throttle regulation:

- 1) THROTTLE 0 ZONE
- 2) THROTTLE X POINT
- 3) THROTTLE Y POINT

**THROTTLE 0 ZONE:** the speed of the truck remains at frequency creep meanwhile the voltage from the accelerator potentiometer is lower than this percentage of the MAX VACC setting. This adjustment define the width of a dead zone close to the neutral position.

**THROTTLE X POINT & THROTTLE Y POINT:** the speed of the truck grows up with a fixed slope (linear relationship) from the THROTTLE 0 ZONE up to THROTTLE X POINT. This slope is defined by the matching between the X point percentage of the MAX VACC setting with the Y point percentage of the full truck speed.

From the X point up to the MAX VACC point, the slope of the relationship between the truck speed and the accelerator position is different (see figure below) to match the full speed in the truck with the MAX VACC voltage in the accelerator position.

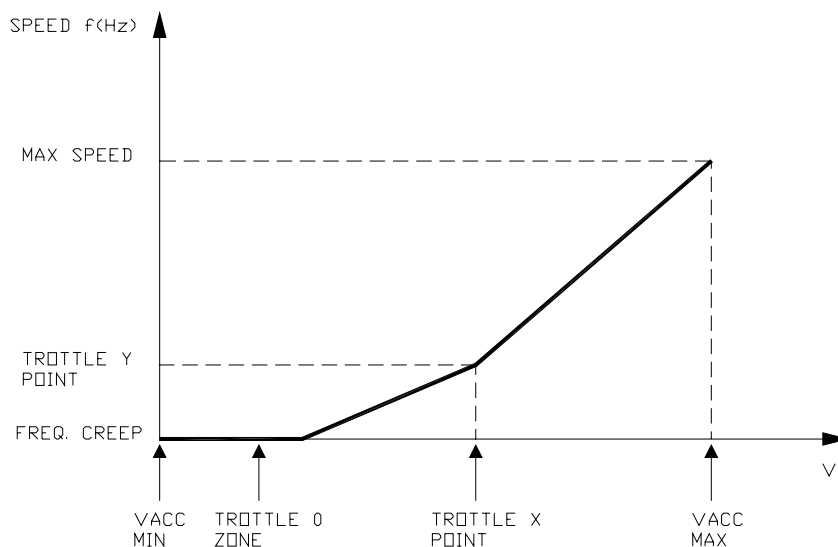

## 10.5 Description of the battery charge detection setting

The Battery Charge detection uses two settings that specify the Full Charge Voltage Level (100%) and the Discharge Voltage Level (10%). These two settings are the Bat.Max.Adj and the Bat.Min.Adj. It is possible to adapt the Battery Charge Detection to your specific battery, by changing the above two settings (e.g. if the Battery Discharged Detection occurs when the battery is not totally discharged, it is necessary to reduce the Bat.Min.Adj setting as indicated in the figure below).

### 48V NOMINAL BATTERY VOLTAGE

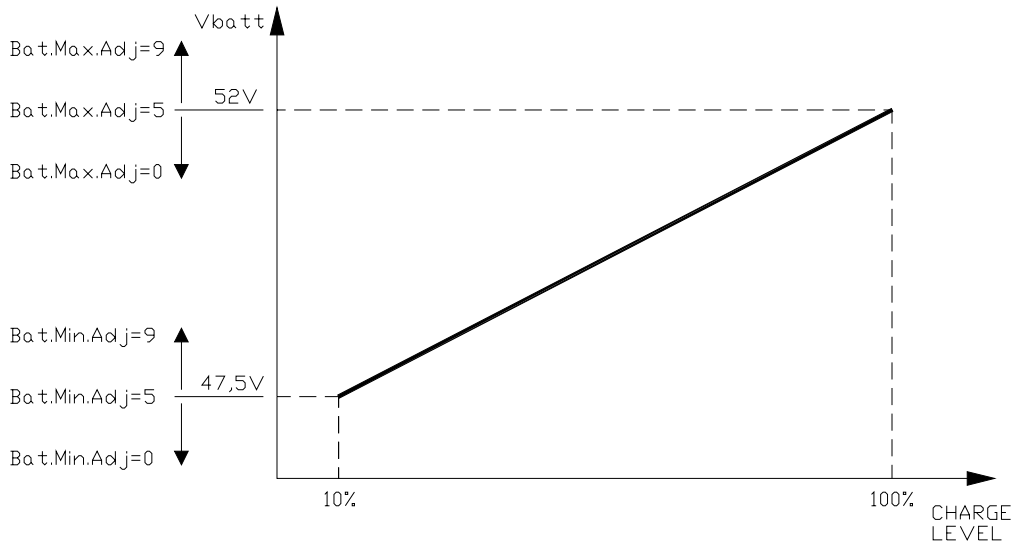

### 24V NOMINAL BATTERY VOLTAGE

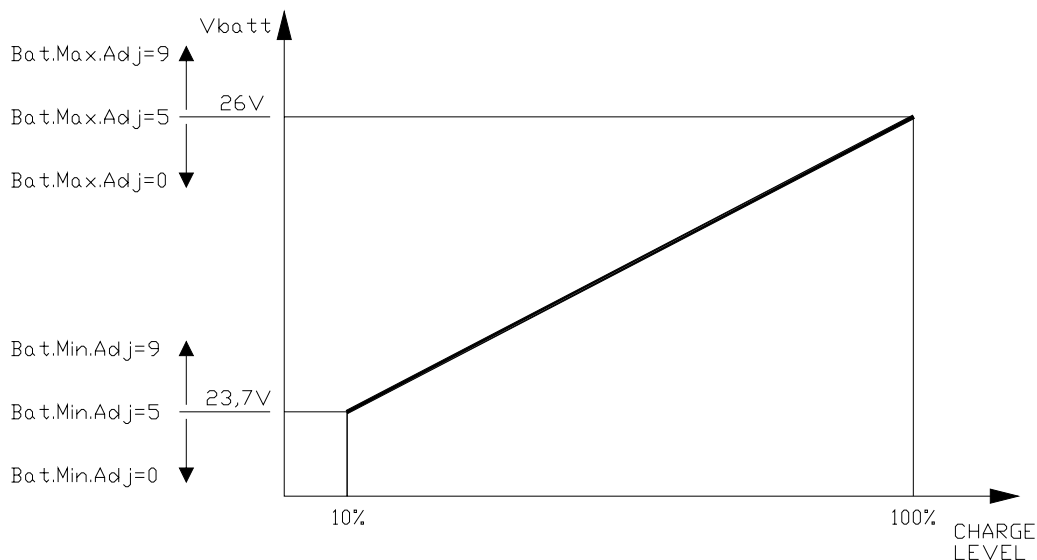

The Battery Charge detection follows this algorithm:

- 1) Battery voltages is read when the Battery current is zero, that is when the output power stage is not driven.
- 2)  $V_{batt}$  is the mean of the least samples measured by the microcontroller converter (the samples are took on key input).
- 3)  $V_{batt}$  is compared with a threshold value (function of the actual charge percentage) in a table and with comparison is found a new charge percentage.
- 4) Thresholds value can be changed with parameters Bat. Max. Adj. and Bat. Min. Adj.
- 5) After key on battery charge can be only increased if the battery charge computed after key on is greater than the last value stored in Eeprom the battery charge value is updated otherwise the Battery charge is not updated.

# 11 COMBI AC1 ALARMS LIST

The ALARMS logbook in the MAIN MENU' records the alarms of the controller. It has a FIFO (First Input First Output) structure that means the oldest alarm is lost when the database is full and a new alarm occurs. The logbook is composed of five locations getting possible to stack five different type of alarms with the following information:

- 1) The alarm code
- 2) The times that each alarm occurs consecutively
- 3) The Hour Meter value when the first event of every alarm occurred
- 4) And the inverter temperature when the first event of every alarm occurred.

This function permits a deeper diagnosis of problems as the recent history can be revised.

**NOTE:** if the same alarm is continuously happening, the controller does not use new memory of the logbook, but only updates the last memory cell increasing the related counter (point 2) of previous list). Nevertheless, the hourmeter indicated in this memory refers to the first time the alarm occurred. In this way, comparing this hourmeter with the controller hourmeter, it is possible to determine:

- When this alarm occurred the first time.
- How many hours are elapsed from the first occurrence to now
- How many times it has occurred in said period.

---

## 11.1 Faults diagnostic system

The fault diagnostic system of Combiac1 controller is divided into 2 main groups of faults:

**ALARMS:** these are the faults which open the power section, which means the power bridge is opened and, when possible, the LC is opened and EB is applied.

These are faults related to:

- failures in the motor/controller that the power system is not anymore able to drive the truck
- safety related failures

**WARNINGS:** these are faults which do not stop the truck or stop it by a controlled regen braking. In other words, the controller is working well, but it has detected conditions to reduce the performances or to stop the truck without opening the power devices.

These warnings are related to:

- wrong operator sequences
- conditions which require performance reduction (like high temperatures, ....)



## 11.2 Master microcontroller alarms overview

Master error code	Related slave error code	Description	Effect	Machine status when the test is done	Restart procedure
Capacitor charge	Waiting for trac	Power capacitors voltage does not increase	Valve, pump, traction stopped, Lc opened, Eb applied	start-up	Valve or pump or traction request
Vmn low	Waiting for trac	Motor output voltage lower than expected	Valve, pump, traction stopped, Lc opened, Eb applied	start-up	Valve or pump or traction request
Vmn high	Waiting for trac	Motor output voltage higher than expected	Valve, pump, traction stopped, Lc opened, Eb applied	start-up	Valve or pump or traction request
Power mos shorted	Waiting for trac	Short circuit on the power mosfets	Valve, pump, traction stopped, Lc opened, Eb applied	start-up	Valve or pump or traction request
Coil short hw ko	Waiting for trac	Problem on the hardware circuit which manages shortcircuits on Lc/Eb coils	Valve, pump, traction stopped, Lc opened, Eb applied	start-up	Valve or pump or traction request
Coil shorted	Waiting for trac	Shortcircuit on LC or EB coils	Valve, pump, traction stopped, Lc opened, Eb applied	stby, traction	Valve or pump or traction request
Driver shorted	Waiting for trac	Driver of Lc coil is shorted, so it is not able to open the Lc	Valve, pump, traction stopped, Lc opened, Eb applied	start-up, stby, traction	Valve or pump or traction request
Contacto Driver	Waiting for trac	Driver of Lc coil is damaged (not able to close)	Valve, pump, traction stopped, Lc opened, Eb applied	stby, traction	Valve or pump or traction request
Contacto Open	Waiting for trac	The Lc coil has been driven but Lc does not close	Valve, pump, traction stopped, Lc opened, Eb applied	stby, traction	Valve or pump or traction request
Contacto closed	Waiting for trac	LC contact is stuck	Valve, pump, traction stopped, Lc opened, Eb applied	start-up	Valve or pump or traction request
Aux driv. Shrt.	Waiting for trac	When the mos of EB is shorted	Valve, pump, traction stopped, Lc opened, Eb applied	start-up, stby, marcia	Valve or pump or traction request
Aux driver open	Waiting for trac	Driver of Eb coil is damaged (not able to close)	Valve, pump, traction stopped, Lc opened, Eb applied	stby, traction	Valve or pump or traction request
Pos aux short	Waiting for trac	Output of built in Smart Driver, which supplies Eb coil positive, is high (= +batt) when the tiller switch is opened.	Valve, pump, traction stopped, Lc opened, Eb applied	start-up	Valve or pump or traction request
Logic Failure #1	Waiting for trac	Overvoltage/Undervoltage condition has been detected	Valve, pump, traction stopped, Lc opened, Eb applied	start-up, stby, traction	Valve or pump or traction request
Logic Failure #2	Waiting for trac	Motor voltage feedback circuits are damaged	Valve, pump, traction stopped, Lc opened, Eb applied	stby, immediately after Lc closing	Valve or pump or traction request
Logic failure #3	Waiting for trac	Failure in the high current HW protection circuit	valve, pump, traction stopped, Lc opened, Eb applied	start-up, stby	Valve or pump or traction request
Stby i high	Waiting for trac	In stby condition (no current applied to the motor) the current feedbacks are aout of permitted stby range	Valve, pump, traction stopped, Lc opened, Eb applied	start-up, stby	Valve or pump or traction request
Wrong Set Battery	Waiting for trac	The battery voltage is too low or too high (< 0,8 Vbatt OR > 1,2 Vbatt)	Valve, pump, traction stopped, Lc opened, Eb applied	start-up, stand-by (only immediately after Lc closing)	Valve or pump or traction request
Analog input	Waiting for trac	Problem on the A/D conversion of Master uC	Valve, pump, traction stopped, Lc opened, Eb applied	start-up, stby, traction	Valve or pump or traction request
Encoder Error	Waiting for trac	Problem on the encoder	Valve, pump, traction stopped, Lc opened, Eb applied	start-up, stby, traction	Valve or pump or traction request
Tiller error	Waiting for trac	Input mismatch between hard&soft switch input and tiller input	Valve, pump, traction stopped, Lc opened, Eb applied	start-up, stby, traction	Valve or pump or traction request
Watchdog	Waiting for trac	Master uC does not receive via canbus the correct stuffing bit from Slave uC	Valve, pump, traction stopped, Lc opened, Eb applied	start-up, stby, traction	Key re-cycle
Hw Fault	Waiting for trac	Master uC has detected that slave uC is not able to stop traction enable or EB-LC enable	Valve, pump, traction stopped, Lc opened, Eb applied	start-up, stand-by (only immediately after Lc closing)	Key re-cycle
No can msg N5	Waiting for trac	No can message from slave uC	Valve, pump, traction stopped, Lc opened, Eb applied	start-up, stby, traction	Key re-cycle
Wrong setpoint	Waiting for trac	Master uC has detected a Slave uC wrong hydraulic function setpoint	Valve, pump, traction stopped, Lc opened, Eb applied	continuous	Key re-cycle
Safety Feedback	Waiting for trac	Master uC has detected a problem on the feedback of EVP driver	Valve, pump, traction stopped, Lc opened, Eb applied	continuous	Key re-cycle

## 11.3 Analysis and troubleshooting of Master microcontroller alarms

To Enter the MAIN MENU' push the Enter button at the Home Page of the hand set display and Roll for the ALARMS item. Here is the ALARMS list:

- 1) "CAPACITOR CHARGE"  
Follows the charging capacitor system:

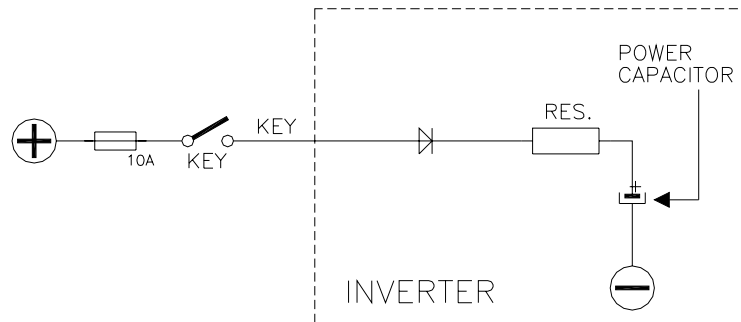

When the key is switched ON, the inverter tries to charge the power capacitors through a power resistance, and check if the capacitor are charged within a timeout. If they do not charge, an alarm is signalled; the main contactor is not closed.

### Troubleshooting:

- A) There is an external load in parallel to capacitor bank, which sinks current from the controller capacitors precharging circuit, thus preventing the caps from charging. Check if a lamp or a dc/dc converter or a auxiliary load is placed in // to capacitor bank.
- B) The charging resistance is opened; insert a power resistance across line contactor power terminals; if the alarm disappears, it means the controller internal charging resistance is damaged.
- C) The charging circuit has a failure, inside the controller.
- D) There is a problem in the controller power section.

- 2) "VMN LOW"

### Cause 1: start-up test.

Before switching the LC on, the software checks the power bridge: it turns on alternately the High side Power Mosfets and expects the phases voltage to increase toward the rail capacitor value. If the phases voltage does not increase, this alarm occurs.

### Cause 2:

Motor running test. When the motor is running, power bridge is ON, the motor voltage feedback is tested; if it is lower than commanded value, fault status is entered.

### Troubleshooting:

- A) If the problem occurs at start up (the LC does not close at all), check:
  - Motor internal connections (ohmic continuity)
  - Motor power cables connections
  - Motor leakage to truck frame
  - If the motor connections are OK, the problem is inside the controller
- B) If the alarm occurs during motor running, check:
  - Motor connections
  - If motor phases windings/cables have leakages towards truck frame
  - That the LC power contact closer properly, with a good contact

- If no problem are found on the motors, the problem is inside the controller.
- 3) “VMN HIGH”
- Cause 1:  
Before switching the LC on, the software checks the power bridge: it turns on alternately the Low side Power Mosfets and expects the phases voltage to decrease down to -BATT. If the phases voltage do not decrease, this alarm occurs.
- Cause 2:  
This alarm may occur also when the start up diagnosis is overcome, and so the LC is closed. In this condition, the phases’ voltages are expected to be lower than 1/2 Vbatt. If it is higher than that value, fault status is entered.
- Troubleshooting:
- A) If the problem occurs at start up (the LC does not close at all), check:
    - Motor internal connections (ohmic continuity)
    - Motor power cables connections
    - If the motor connection are OK, the problem is inside the controller
  - B) If the problem occurs after closing the LC (the LC closed and then opens back again), check:
    - Motor connections
    - If motor phases windings/cables have leakages towards truck frame
    - If no problem are found on the motors, the problem is inside the controller
- 4) “POWER MOS SHORTED”
- Cause: Before switching the LC on, the software checks the power bridge: it turns on alternately the Low side and High side Power Mosfets and expects the phases voltage to decrease down to -BATT (increase up to +Batt). If the phases voltage do not follow the commands, this alarm occurs.
- Troubleshooting:  
This type of fault is not related to external components; replace the controller.
- 5) “COIL SHORT HW KO”
- Cause:  
The hardware circuits which manages short circuits protection of LC and EB coils has a problem.
- Troubleshooting:  
This type of fault is not related to external components; replace the controller.
- 6) “COIL SHORTED”
- Cause:  
This alarm occurs when there is a short circuit of one of the coils connected to outputs of the Combiac1 (LC coil or EB coil). After the overload condition has been removed, the alarm exits automatically by releasing and then enabling a travel demand.
- Troubleshooting:
- A) The typical root cause for this error code to be displayed is in the harness or in the load coil. So the very first check to carry out concerns connections between controller outputs and loads.
  - B) In case no failures/problems have been found externally, the problem is in the controller, which has to be replaced.
- 7) “DRIVER SHORTED”
- Cause:

The driver of the main contactor coil is shorted.

Troubleshooting:

- A) Check if there is a short or a low impedance pull-down between NMCC (CAN#17 in AmpSaab, CAN#12 in AmpSeal) and –BATT.
- B) The driver circuit is damaged in the controller, which has to be replaced.

8) “CONTACTOR DRIVER”

Cause:

The LC coil driver is not able to drive the load. The device itself or its driving circuit is damaged.

Troubleshooting:

This type of fault is not related to external components; replace the controller.

9) “CONTACTOR OPEN”

Cause:

The main contactor coil has been driven by the controller, but the contactor does not close.

Troubleshooting:

- A) The wires to the LC coil are interrupted or not connected, so check the coil related harness.
- B) It could be also a problem of the contact in the LC that is not working (does not pull-in), try replacing the LC.

10) “CONTACTOR CLOSED”

Cause:

Before driving the LC coil, the controller checks if the contactor is stuck. The controller drives the bridge for some tens milliseconds, trying to discharge the capacitors bank. If they don't discharge the fault condition is entered.

Troubleshooting:

It is suggested to verify the power contacts of LC; to replace the LC is necessary.

11) “AUX DRIVER SHORTED”

Cause:

The driver of the electromechanical brake coil is shorted.

Troubleshooting:

- A) Check if there is a short or a low impedance pull-down between NEB (CNA#31 in AmpSaab, CNA#4 in AmpSeal) and –BATT.
- B) The driver circuit is damaged in the controller, which has to be replaced.

12) “AUX DRIVER OPEN”

Cause:

The driver of the electromechanical brake coil is not able to drive the load.

Troubleshooting:

Replace the controller.

13) “POS AUX SHORT”

Cause:

The output of the built in Smart Driver, which supplies the positive to the Electromechanical brake coil is high when the Tiller and the H&S switch are open.

Troubleshooting:

- A) It is suggested to check the harness, in order to verify if a positive is connected to the Smart driver output (CNA#30 AmpSaab connector, CNA#2 AmpSeal connector)

- B) If, even disconnecting the wire from the connector pin, the output stays at high value, the problem is inside the controller and the Smart Driver is probably shorted.

14) "LOGIC FAILURE #1"

This fault is displayed when the controller detects an overvoltage or undervoltage condition. Overvoltage threshold is 45V, undervoltage threshold is 9V in the 24V controller. In 48V controller overvoltage threshold is 65V, undervoltage threshold is 11V.

Troubleshooting of fault displayed at startup or in standby; in these cases it is very likely the fault is due to an undervoltage, so it is suggested to check:

- A) Key input signal down-going pulses (below undervoltage threshold) due to external loads, like DC/DC converters starting-up, relays or contactor switching, solenoids energizing / deenergizing.
- B) If no voltage transient is detected on the supply line and the alarm is present every time the key is switched ON, the failure is probably in the controller hardware, so it is necessary to replace the controller.

Troubleshooting of fault displayed during motor driving; in this case it can be an undervoltage or a overvoltage condition.

- A) If the alarm happens during traction acceleration or driving hydraulic functions, it is very likely it is an undervoltage condition; check battery charge condition, power cable connection.
- B) If the alarm happens during release braking, it is very likely it is due to overvoltage condition; check line contactor contact, battery power cable connection.

15) "LOGIC FAILURE #2"

Cause:

Fault in the hardware section of the logic board which manages the phase's voltage feedback.

Troubleshooting:

This type of fault is not related to external components, so when it happens it is necessary to replace the Controller.

16) "LOGIC FAILURE #3"

Cause:

Hardware problem in the logic card circuit for high current (overload) protection.

Troubleshooting:

This type of fault is not related to external components, so, when it is present it is necessary to replace the controller.

17) "STBY I HIGH"

Cause:

The current transducer or the current feedback circuit is damaged in the controller.

Troubleshooting:

This type of fault is not related to external components so, when it is present, it is necessary to replace the controller.

18) "WRONG SET BATTERY"

Cause:

At start-up, the controller checks the battery voltage and verify it is within a

window around the nominal value.

Troubleshooting:

- A) Check that the controller SET BATTERY parameter value matches the battery nominal voltage.
- B) Check that the TESTER MENU / BATTERY VOLTAGE parameter shows same value as the battery voltage measured with a voltmeter. If it does not match, then do a “ADJUST BATTERY” function.
- C) Replace the battery.

19) “ANALOG INPUT”

Cause:

This alarm occurs when the A/D conversion of the analog inputs gives frozen value, on all of the converted signals, for more than 400msec. The goal of this diagnosis is to detect a failure of the A/D converter or a problem in the code flow that omits the refreshing of the analog signal conversion.

Troubleshooting:

If the problem occurs permanently it is necessary to substitute the controller.

20) “ENCODER ERROR”

Cause:

This fault is signalled in following conditions: the frequency supplied to the motor is higher than 40 Hz and the signal feedback from the encoder has a jump higher than 40 Hz in few tens mSec. This condition is related to a malfunctioning of the encoder.

Troubleshooting:

- A) Check both the electric and the mechanical encoder functionality, the wires crimping.
- B) Check the encoder mechanical installation, if the encoder slips inside its compartment raising this alarm condition.
- C) Also the electromagnetic noise on the sensor bearing can be a cause for the alarm. In these cases try to replace the encoder.
- D) If the problem is still present after replacing the encoder, the failure is in the controller.

21) “TILLER ERROR”

Cause:

Mismatch between the H&S input and the tiller input.

Troubleshooting:

Check the harness related to CNA#6 and CNA#7 in AmpSaab connector (CNA#29 and CNA1 in AmpSeal connector) with a voltmeter. If the state of these inputs is right, then it could be a problem inside the controller, which has to be changed.

22) “WATCHDOG”

Cause:

This is a safety related test. It is a self diagnosis test within the logic between Master and Slave microcontrollers.

Troubleshooting:

This alarm could be caused by a canbus malfunctioning, which blinds master-slave communication. Otherwise it is an internal fault of the controller which must be replaced.

23) “HARDWARE FAULT”

Cause:

The master microcontroller has detected that the slave microcontroller is not able to stop the traction enable or LC-EB enable.

Troubleshooting:

The problem is inside the logic of the inverter, replace the controller.

24) "NO CAN MESSAGE N5"

Cause:

No Can messages from the slave microcontroller.

Troubleshooting:

This alarm could be caused by a canbus malfunctioning, which blinds master-slave communication. Otherwise it is an internal fault of the controller which must be replaced.

25) "WRONG SETPOINT"

Cause:

This is a safety related test. The Master  $\mu$ C has detected a Slave  $\mu$ C wrong hydraulic function setpoint.

Troubleshooting:

This is a internal fault of the controller, it is necessary to replace it.

26) "SAFETY FEEDBACK"

Cause:

This is a safety related test. Master  $\mu$ C has detected a problem on the feedback of EVP driver.

Troubleshooting:

This is a internal fault of the controller, it is necessary to replace it.

## 11.4 Master warnings overview

Master error code	Related Slave error code	Description	Effect	Machine status when the test is done	Restart procedure
Pump Warning		Slave has a warning			
Slip profile		Error on the parameters of the slip profile setting.	Traction is stopped	start-up, stand-by, traction	Traction request
Forward+backward		The travel demands are active in both directions at the same time	Traction is stopped	start-up, stand-by, traction	Traction request
Incorrect start		Incorrect starting sequence	Traction is stopped	start-up, stand-by, traction	Traction request
Vacc not ok		The acceleretor value is higher than the minimum value recorded, and the direction/enable switches are opened.	Traction is stopped	start-up, stand-by, traction	Traction request
High temperature		The controller has reached the thermal cutback temperature 85°C	Traction controller reduces the maximum current linearly from I <sub>max</sub> (85°C) down to 0A (105°C)	continuous	
Battery low		Battery is <= 10% when the parameter BATTERY CHECK is set >0	The maximum current is reduced to half and speed is reduced (if CHECK OPTION = 1)	continuous	
Eeprom ko		Error is detected in eeprom or in eeprom management	Controller works using Default parameters	continuous	
Motor temperature		Motor temperature sensor is opened (if digital) or has overtaken the threshold of 150°C (if analog)	The maximum current is reduced to half and speed is reduced	continuous	
Thermic sens ko		The output of the controller thermal sensor is out of range.	The maximum current is reduced to half and speed is reduced	continuous	
Check up needed		Maintenance time is reached			
Data acquisition		Maximum current adjustment procedure is in progress (NOTE: this procedure has to be done only by Zapi test department)	Traction is stopped	stand-by	Traction request
Pedal wire ko		Acceleartor poti negative (Npot) voltage is out of range (less than 0,3V or >2V)	Traction is stopped	start-up, stand-by, traction	Traction request
Tiller open		Tthe truck is in stby with tiller switch opened for more than 30s	LC opens	standby	Valve or pump or traction request
Current gain		The Maximum current gain parameters are @ the default values, which means the maximum current adjustment procedure has not been carried out yet	Controller works, but with low maximum current	start-up, stanby	
Waiting for node		Slave uC is in alarm condition, Master uC is waiting for it to resolve its error condition		continuous	



---

## 11.5 Analysis and troubleshooting of Master warnings

- 1) "PUMP WARNING"  
Cause:  
The slave has a warning.  
Troubleshooting:  
Connect to the slave with the hand set console and check the warning.
  
- 2) "SLIP PROFILE"  
Cause:  
There is an error on the choice of the parameters of the slip profile.  
Troubleshooting:  
Check in the hardware setting menu the value of those parameters.
  
- 3) "FORW+BACK"  
Cause:  
This alarm occurs when both the travel demands (Fwd and Bwd) are active at the same time.  
Troubleshooting:  
Check the wiring of the Fwd and Rev travel demand inputs (use the readings in the TESTER to facilitate the troubleshooting). Check the microswitches for failures.  
A failure in the logic is possible too. So, when you have verified the travel demand switches are fine working and the wiring is right, it is necessary to replace the controller.
  
- 4) "INCORRECT START"  
Cause:  
This is a warning for an incorrect starting sequence.  
Troubleshooting:  
The possible reasons for this alarm are (use the readings in the TESTER to facilitate the troubleshooting):  
A) A travel demand active at key on  
B) Presence man sensor active at key on  
Check the wirings. Check the microswitches. It could be also an error sequence made by the operator. A failure in the logic is possible too; so when all of the above conditions were checked and nothing was found, replace the controller.
  
- 5) "VACC NOT OK"  
Cause:  
The test is made at key-on and after 20sec that both the travel demands have been turned off. This alarm occurs if the ACCELERATOR reading in the TESTER menu' is 1,0V higher than PROGRAM VACC min acquisition when the accelerator is released.  
Troubleshooting:  
Check the mechanical calibration and the functionality of the potentiometer.
  
- 6) "HIGH TEMPERATURE"  
Cause:  
This alarm occurs when the temperature of the base plate is higher than 85°. Then the maximum current decreases proportionally with the temperature increases from 85° up to 105°. At 105° the Current is limited to 0 Amps.

Troubleshooting:

Improve the air cooling of the controller. If the alarm is signalled when the controller is cold, the possible reasons are a thermal sensor failure or a failure in the logic card. In this case, it is necessary to replace the controller.

7) "BATTERY LOW"

Cause:

It occurs when the battery charge is calculated being less than or equal to 10% of the full charge and the BATTERY CHECK setting is other than 0 (refer to SET OPTION menu).

Troubleshooting:

Get the battery charged. If it doesn't work, measure with a voltmeter the battery voltage and compare it with the value in the BATTERY VOLTAGE parameter. If they are different adjust the value of the ADJUST BATTERY function.

8) "EEPROM KO"

Cause:

It's due to a HW or SW defect of the non-volatile embedded memory supporting the controller parameters. This alarm does not inhibit the machine operations, but the truck will work with the default values.

Troubleshooting:

Try to execute a CLEAR EEPROM operation (refer to Console manual). Switch the key off and on to check the result. If the alarm occurs permanently, it is necessary to replace the controller. If the alarm disappears, the previously stored parameters will have been replaced by the default parameters.

9) "MOTOR TEMPERATURE"

Cause:

This warning occurs when the temperature sensor is opened (if digital) or has overtaken the threshold of 150° (if analog).

Troubleshooting:

Check the thermal sensor inside the motor (use the MOTOR TEMPERATURE reading in the TESTER menu); check the sensor ohmic value and the sensor wiring. If the sensor is OK, improve the air cooling of the motor. If the warning is present when the motor is cool, then the problem is inside the controller.

10) "THERMIC SENSOR KO"

Cause:

The output of the controller thermal sensor is out of range.

Troubleshooting:

This type of fault is not related to external components; replace the controller.

11) "CHECK UP NEEDED"

Cause:

This is just a warning to call for the time programmed maintenance.

Troubleshooting:

It is just enough to turn the CHECK UP DONE option to level ON after the maintenance is executed.

12) "DATA ACQUISITION"

Cause:

Acquisition of the current gains.

Troubleshooting:

The alarm ends when the acquisition is done.

13) "PEDAL WIRE KO"

Cause:

The SW continuously checks for the connection of the two supply ends of the potentiometer in the accelerator. The test consists of reading the voltage drop on a sense diode, connected between NPOT (CNA#23 in AmpSaab connector) and GND and cascaded with the potentiometer: if the potentiometer gets disconnected on PPOT (CNA#26 in AmpSaab connector) or NPOT, no current flows in this sense diode and the voltage on the NPOT connection collapses down.

When the NPOT voltage is less than 0.3V this alarm occurs. This alarm occurs also when the NPOT voltage is higher than 2Vdc (to detect also the condition of a broken sense diode).

Troubleshooting:

Check the voltage on NPOT and the potentiometer connections.

14) "TILLER OPEN"

Cause:

Warning: when the tiller is released, after a fixed period of time of standby (30 seconds) the main contactor open.

Troubleshooting:

At the next travel request the warning disappear.

15) "CURRENT GAIN"

Cause:

The Maximum current gain parameters are at the default values, which means the maximum current adjustment procedure has not been carried out yet.

Troubleshooting:

Ask the assistance of a Zapi technician to do the correct adjustment procedure of the current gain parameters.

16) "WAITING FOR NODE"

Cause:

The controller receives from the CAN the message that another controller in the net is in fault condition; as a consequence the traction controller itself cannot enter an operative status, but has to WAIT for the other controller coming out from the fault status.

## 11.6 Slave alarms overview

Slave error code	Related Master error code	Description	Effect	Machine status when the test is done	Restart procedure
Evp Driver Shorted	Waiting for Node	Evp driver is failed shorted (always ON)	valve, pump, traction stopped, Lc opened, Eb applied	start-up, stby	valve or pump or traction request
Pump Vmn Low	Waiting for Node	Pump motor output is too low, with respect to pwm applied	valve, pump, traction stopped, Lc opened, Eb applied	start-up, stby, during pump function	valve or pump or traction request
Pump Vmn High	Waiting for Node	Pump motor output is too high, with respect to pwm applied	valve, pump, traction stopped, Lc opened, Eb applied	during pump function	valve or pump or traction request
analog input	Waiting for Node	Problem on the A/D conversion of uC	valve, pump, traction stopped, Lc opened, Eb applied	continuous	valve or pump or traction request
logic failure#1	Waiting for Node	Overvoltage/Undervoltage condition has been detected	valve, pump, traction stopped, Lc opened, Eb applied	continuous	valve or pump or traction request
Wrong Zero	Waiting for Node	The outputs of the amplifiers (used to measure the motor currents and voltage) are cheked to be near null. This alarm occurs when current signals are >2,85V or <2,15V. Voltage signals >3V or <2V at the init	valve, pump, traction stopped, Lc opened, Eb applied	init (for iv,iw,huw,hvw) rpm>20Hz(lv,lu)	valve or pump or traction request
Safety Feed (TG)	Waiting for Node	Slave uC has detected a problem on the feedback of Lc driver	valve, pump, traction stopped, Lc opened, Eb applied	continuous	Key re-cycle
Safety Feed (Eb)	Waiting for Node	Slave uC has detected a problem on the feedback of Eb driver	valve, pump, traction stopped, Lc opened, Eb applied	continuous	Key re-cycle
Wrong setpoint	Waiting for Node	Slave uC has detected a Master uC wrong hydraulic function setpoint	Valve, pump, traction stopped, Lc opened, Eb applied	continuous	Key re-cycle
Input MisMatch	Waiting for Node	Slave uC has detected a mismatch between its input (digital, analog and encoder) and correspondant Master uC inputs	Valve, pump, traction stopped, Lc opened, Eb applied	continuous	Key re-cycle
Output MisMatch	Waiting for Node	Slave uC has detected a condition that the Master uC is driving traction motor in a wrong way (not correspondant to the status of operator commands)	Valve, pump, traction stopped, Lc opened, Eb applied	continuous	Key re-cycle
watchdog	Waiting for Node	Controllo che lo master passi in più punti del programma e inverta i bit del slave	valve, pump, traction stopped, Lc opened, Eb applied	continuous	Key re-cycle
No can Msg #2	Waiting for Node	Can messages from Master uC are lost	valve, pump, traction stopped, Lc opened, Eb applied	continuous	Key re-cycle
Hw Fault	Waiting for Node	Slave uC has detected that Master uC is not able to stop hydraulic functions	valve, pump, traction stopped, Lc opened, Eb applied	start-up (EVP related test) stby (pump chopper related test)	Key re-cycle

---

## 11.7 Analysis and troubleshooting of Slave alarms

1) "EVP DRIVER SHORTED"

Cause:

The EVP driver is shorted.

Troubleshooting:

Check if there is a short or a low impedance between the negative of the coil and -BATT. Otherwise the driver circuit is damaged and the controller must be replaced.

2) "PUMP VMN LOW"

Cause:

The pump motor output is lower than expected, considering the pwm applied.

Troubleshooting:

A) If the problem occurs at start up (the LC does not close at all), check:

- Motor internal connections (ohmic continuity)
- Motor power cables connections
- If the motor connection are OK, the problem is inside the controller

B) If the problem occurs after closing the LC (the LC closed and then opens back again), check:

- Motor connections
- If motor windings/cables have leakages towards truck frame
- If no problem are found on the motors, the problem is inside the controller

C) If the alarm occurs during motor running, check:

- Motor connections
- If motor windings/cables have leakages towards truck frame
- That the LC power contact closer properly, with a good contact
- If no problem are found on the motors, the problem is inside the controller.

3) "PUMP VMN HIGH"

Cause:

This test is carried out when the pump motor is turning (pwm applied). The pump motor output is higher than expected, considering the pwm applied.

Troubleshooting: it is suggested to check:

A) Motor connections

B) If motor windings/cables have leakages towards truck frame

C) If no problem are found on the motors, the problem is inside the controller

4) "ANALOG INPUT"

Cause:

This alarm occurs when the A/D conversion of the analog inputs gives frozen value, on all of the converted signals, for more than 400msec. The goal of this diagnosis is to detect a failure of the A/D converter or a problem in the code flow that omits the refreshing of the analog signal conversion.

Troubleshooting:

If the problem occurs permanently it is necessary to substitute the controller.

5) "LOGIC FAILURE #1"

Cause:

This fault is displayed when the controller detects an overvoltage or

undervoltage condition. Overvoltage threshold is 45V, undervoltage threshold is 9V in the 24V controller. In 48V controller overvoltage threshold is 65V, undervoltage threshold is 11V.

Troubleshooting of fault displayed at startup or in standby; in these cases it is very likely the fault is due to an undervoltage, so it is suggested to check:

- A) Key input signal down-going pulses (below undervoltage threshold) due to external loads, like DC/DC converters starting-up, relais or contactor switching, solenoids energizing / deenergizing.
- B) If no voltage transient is detected on the supply line and the alarm is present every time the key is switched ON, the failure is probably in the controller hardware, so it is necessary to replace the controller.

Troubleshooting of fault displayed during motor driving; in this case it can be an undervoltage or a overvoltage condition.

- A) If the alarm happens during traction acceleration or driving hydraulic functions, it is very likely it is an undervoltage condition; check battery charge condition, power cable connection.
- B) If the alarm happens during release braking, it is very likely it is due to overvoltage condition; check line contactor contact, battery power cable connection.

6) "WRONG ZERO"

Cause:

The outputs of the amplifiers (used to measure the motor currents and voltage) are checked to be near null. This alarm occurs when current signals are  $>2,85V$  or  $<2,15V$ . Voltage signals  $>3V$  or  $<2V$  at the init.

Troubleshooting:

This type of fault is not related to external components; replace the controller.

7) "SAFETY FEED (TG)"

Cause:

This is a safety related test. Slave  $\mu C$  has detected a problem on the feedback of Lc driver.

Troubleshooting:

This is a internal fault of the controller, it is necessary to replace it.

8) "SAFETY FEED (EB)"

Cause:

This is a safety related test. Slave  $\mu C$  has detected a problem on the feedback of Eb driver.

Troubleshooting:

This is a internal fault of the controller, it is necessary to replace it.

9) "WRONG SETPOINT"

Cause:

This is a safety related test. Slave  $\mu C$  has detected a Master  $\mu C$  wrong traction function setpoint.

Troubleshooting:

This is a internal fault of the controller, it is necessary to replace it.

10) "INPUT MISMATCH"

Cause:

This is a safety related test. Slave  $\mu C$  has detected a mismatch between its input (digital, analog and encoder) and correspondant Master  $\mu C$  inputs.

Troubleshooting:

This is a internal fault of the controller, it is necessary to replace it.

11) "OUTPUT MISMATCH"

Cause:

This is a safety related test. Slave  $\mu\text{C}$  has detected that the Master  $\mu\text{C}$  is driving traction motor in a wrong way (not correspondant to the status of operator commands).

Troubleshooting:

This is an internal fault of the controller, it is necessary to replace it.

12) "WATCHDOG"

Cause:

It is a self diagnosis test within the logic between Master and Slave microcontrollers.

Troubleshooting:

This alarm could be caused by a canbus malfunctioning, which blinds master-slave communication. Otherwise it is an internal fault of the controller which must be replaced.

13) "NO CAN MESSAGE#2"

Cause:

No Can messages from the master microcontroller.

Troubleshooting:

This alarm could be caused by a canbus malfunctioning, which blinds master-slave communication. Otherwise the problem is inside the logic, replace the controller.

14) "HW FAULT"

Cause:

The slave has detected that the master microcontroller is not able to stop hydraulic functions.

Troubleshooting:

This type of fault is not related to external components; replace the controller.

## 11.8 Slave warnings overview

Slave error code	Related Master error code	Description	Effect	Machine status when the test is done	Restart procedure
Current Sensor Low	Pump Warning	Pump chopper current sensor feedback too low (below 0,5V)	Pump motor stopped	stby	pump request
Hw Fault Valve	Pump Warning	Problem on the EN-EVS	On/off valves stopped	start-up	valve on/off request
Valve Coil Shorted	Pump Warning	Shortcircuit on On/off coils	On/off valves stopped	start-up, stby, during valve function	valve on/off request
Valve driver shorted	Pump Warning	One or more on/off valve drivers shorted (always ON)	On/off valves stopped	start-up, stby	valve on/off request
Valve Cont driver	Pump Warning	One or more on/off valve drivers opened (not able to close, so not able to drive the valve)	On/off valves stopped	during valve function	valve on/off request
Evp Driver Ko	Pump Warning	Evp driver open (not able to close, so not able to drive the valve)	Evp stopped	during Evp function	valve evp request
Pump Stby I high	Pump Warning	Pump chopper current sensor feedback too high (above 0,8V)	Pump motor stopped	start-up, stby	pump request
Pump I=0 ever	Pump Warning	Pump current feedback is always 0A even when pump motor is running	Pump motor stopped	pump function	pump request
motor temperature	Pump Warning	Pump motor temperature high	Pump chopper maximum current reduced to half	continuous	
waiting for trac	ALARM XXX	Slave is waiting the master			
incorrect start	Pump Warning	Wrong sequence in hydraulic function request	pump/valve stopped	continuous	to do a correct sequence
vacc not ok	Pump Warning	Hydraulic poti (lift/lowering poti) higher than minimum value recorded, in stby condition	pump/Evp stopped	start-up, stby	hydraulic request
ram warning	Pump Warning	checksum ram failed		continuous	
eep warning	Pump Warning	checksum eeprom failed		init	
lift+lower	Pump Warning	lift+lower request	Pump motor stopped	continuous	hydraulic request
eeprom ko	Pump Warning	eeprom is not online, or the parameters in triplicate are different			
Pump motor temperature	Pump Warning	When the parameter SET TEMPERATURE is setted, the temperature of the motor is >150°C	Maximum current is halved	continuous	
high temperature	Pump Warning	When the parameter maximum current is 100% the current is reduced lineary from 85°C to 105°C	Pump chopper maximum current reduced proportionally to T increase	continuous	
reduction by master	Pump Warning	Master requests a reduction	pump speed reduced	continuous	



---

## 11.9 Analysis and troubleshooting of Slave warnings

1) "CURRENT SENSOR LOW"

Cause:

The pump chopper current sensor feedback is too low (below 0.5V).

Troubleshooting:

This type of fault is not related to external components; replace the controller.

2) "HW FAULT VALVE"

Cause:

The slave has detected that the master microcontroller is not able to stop hydraulic valves functions

Troubleshooting:

This fault is not related to external components, so it is necessary to replace the controller.

3) "VALVE COIL SHORTED"

Cause:

This alarm occurs when there is a short circuit on an on/off valve coil.

Troubleshooting:

A) If the fault is present at start up, it is very likely that the hw overcurrent protection circuit is damaged, it is necessary to replace the controller.

B) If the fault is present when the controller drives the outputs, the problem is located in the harness and in the coils.

4) "VALVE DRIVER SHORTED"

Cause:

One or more on/off valve drivers are shorted.

Troubleshooting:

Check if there is a short or a low impedance between the negative of one of those coils and -BATT. Otherwise the driver circuit is damaged and the controller must be replaced.

5) "VALVE CONT DRIVER"

Cause:

One or more on/off valve drivers is not able to drive the load (cannot close).

Troubleshooting:

The device or its driving circuit is damaged, replace the controller.

6) "EVP DRIVER KO"

Cause:

The EVP valve driver is not able to drive the load (cannot close).

Troubleshooting:

The device or its driving circuit is damaged, replace the controller.

7) "PUMP STBY I HIGH"

Cause:

In standby condition (pump motor not driven), the feedback coming from the current sensor in the pump chopper gives a value too high (>0,8).

Troubleshooting:

This type of fault is not related to external components; replace the controller.

- 8) "PUMP I=0 EVER"  
Cause:  
This test is carried out when the pump motor is running, and it verifies that the current feedback sensor is not constantly stuck to 0.  
Troubleshooting:  
A) Check the motor connection, that there is continuity. If the motor connection is opened, the current cannot flow, so the test fails and the error code is displayed.  
B) If everything is ok for what it concerns the motor, the problem could be in the current sensor or in the related circuit.
- 9) "MOTOR TEMPERATURE"  
Cause:  
This warning occurs when the temperature sensor is opened (if digital) or has overtaken the threshold of 150° (if analog).  
Troubleshooting:  
Check the thermal sensor inside the motor (use the MOTOR TEMPERATURE reading in the TESTER menu); check the sensor ohmic value and the sensor wiring. If the sensor is OK, improve the air cooling of the motor. If the warning is present when the motor is cool, then the problem is inside the controller.
- 10) "WAITING FOR TRACTION"  
Cause:  
The controller receive from the CAN the message that Master controller is in fault condition; as a consequence the pump controller itself cannot enter an operative status, but has to WAIT for the Master controller coming out from the fault condition.
- 11) "INCORRECT START"  
Cause:  
This is a warning for an incorrect starting sequence.  
Troubleshooting:  
The possible reasons for this alarm are (use the readings in the TESTER to facilitate the troubleshooting):  
A) A hydraulic function demand active at key on  
B) Deadman sensor active at key on  
Check the wirings. Check the microswitches. It could be also an error sequence made by the operator. A failure in the logic is possible too; so when all of the above conditions were checked and nothing was found, replace the controller.
- 12) "VACC NOT OK"  
Cause:  
The test is made at key-on and after 20sec that the hydraulic potentiometer (Lift/Lowering) is back to neutral position. This alarm occurs if the Lift / Lowering potentiometer reading in the TESTER menu' is 1,0 V higher than the minimum value when the Lift/Lower accelerator is released.  
Troubleshooting:  
Check the mechanical calibration and the functionality of the potentiometer.
- 13) "RAM WARNING"  
Cause:  
Checksum of the ram failed.  
Troubleshooting:  
This fault is not related to external components.

14) "EEP WARNING"

Cause:

Eeprom checksum failed

Troubleshooting:

Try to execute a CLEAR EEPROM operation (refer to Console manual).

Switch the key off and on to check the result. If the alarm occurs permanently, it is necessary to replace the controller. If the alarm disappears, the previously stored parameters will have been replaced by the default parameters.

15) "LIFT + LOWER"

Cause:

This alarm occurs when both forks movement requests(Lift + Lower) are active at the same time.

Troubleshooting:

Check the wiring of the Lift and lower inputs (use the readings in the TESTER to facilitate the troubleshooting). Check the microswitches for failures.

A failure in the logic is possible too. So, when you have verified the travel demand switches are fine working and the wiring is right, it is necessary to replace the controller.

16) "EEPROM KO"

Cause:

It's due to a HW or SW defect of the non-volatile embedded memory supporting the controller parameters. This alarm does not inhibit the machine operations, but the truck will work with the default values.

Troubleshooting:

Try to execute a CLEAR EEPROM operation (refer to Console manual).

Switch the key off and on to check the result. If the alarm occurs permanently, it is necessary to replace the controller. If the alarm disappears, the previously stored parameters will have been replaced by the default parameters.

17) "PUMP MOTOR TEMPERATURE"

Cause:

This warning occurs when the temperature sensor is opened (if digital) or has overtaken the threshold of 150° (if analog).

Troubleshooting:

Check the thermal sensor inside the motor (use the MOTOR TEMPERATURE reading in the TESTER menu); check the sensor ohmic value and the sensor wiring. If the sensor is OK, improve the air cooling of the motor. If the warning is present when the motor is cool, then the problem is inside the controller.

18) "HIGH TEMPERATURE"

Cause:

This alarm occurs when the temperature of the power section plate is higher than 75°. Then the maximum current decreases proportionally with the temperature increases from 85° up to 105°. At 105° the Current is limited to 0 Amps.

Troubleshooting:

Improve the air cooling of the controller. If the alarm is signaled when the controller is cold, the possible reasons are a thermal sensor failure or a failure in the logic card. In this case, it is necessary to replace the controller.

19) "REDUCTION BY MASTER"

Cause:

The master has requested a reduction of performance of the slave.

Troubleshooting:

Check in the master the cause of the reduction.

## 12 RECOMMENDED SPARE PARTS

Part number	Description
C16506	FUSE PROT. 425A INTERAS60 (for 24v and 48v version)
C12505	AMPSAAB CONNECTOR 42 pins Female
C12532	AMPSEAL CONNECTOR 35 pins Female

# 13 PERIODIC MAINTENANCE TO BE REPEATED AT TIMES INDICATED

Check the wear and condition of the Contactors' moving and fixed contacts. Electrical Contacts should be checked every **3 months**.

Check the wear and condition of the electromechanical brake. According with the ISO 6292 the electromechanical brake must be able to lock the truck in the worst case in terms of admitted gradient and load. The truck manufacturer has to take care the ISO 6292 is fulfilled with a suited maintenance scheduling.

Check the Foot pedal or Tiller microswitch. Using a suitable test meter, confirm that there is no electrical resistance between the contacts by measuring the volt drop between the terminals. Switches should operate with a firm click sound. Microswitches should be checked every **3 months**.

Check the Battery cables, cables to the chopper, and cables to the motor. Ensure the insulation is sound and the connections are tight. Cables should be checked every **3 months**.

Check the mechanical operation of the pedal or tiller . Are the return springs ok. Do the potentiometers wind up to their full or programmed level. Check every **3 months**.

Check the mechanical operation of the Contactor(s). Moving contacts should be free to move without restriction. Check every **3 months**.

Checks should be carried out by qualified personnel and any replacement parts used should be original. Beware of NON ORIGINAL PARTS. The installation of this electronic controller should be made according to the diagrams included in this Manual. Any variations or special requirements should be made after consulting a Zapi Agent. The supplier is not responsible for any problem that arises from wiring methods that differ from information included in this Manual.

During periodic checks, if a technician finds any situation that could cause damage or compromise safety, the matter should be brought to the attention of a Zapi Agent immediately. The Agent will then take the decision regarding operational safety of the machine.

Remember that Battery Powered Machines feel no pain.

**NEVER USE A VEHICLE WITH A FAULTY ELECTRONIC CONTROLLER**