



# Gen4 DC

## AC Motor Controller

The Gen4 DC sets a new standard in DC brushed motor controller performance and reliability. The Gen4 DC is compatible with a wide range of motors, including Separately Excited Motor (SEM), Permanent Magnet brushed motors and Series wound motors. The Gen4 can be configured to accurately drive the motor in current control mode, offering a real and precise torque control of the motor. Speed control is also available. All types of motor are driven via four-quadrant armature control, resulting in immediate delivery of motor torque and enhanced fault protection of the system. Integrated logic circuitry and vehicle control functionality means that VCU functionality can be configured within the Gen4 DC unit. Speed limitation is available by use of complementary switching MOSFET operation and battery current regeneration is possible in most motor configurations.

## Features

- Integrated IO and logic circuit
- Supports DC SEM, PM Brushed and Series motors
- Hill decent speed limitation (possible with and without speed sensor)
- True torque control
- Hardware and software failsafe watchdog operation
- Integrated Capacitor pre-charge function
- CANopen Bus communication
- Power up auto-check system fault diagnostics
- Motor speed sensor input available
- IP66 protection



## Key Parameters

	400A		550A	
Nominal Battery Voltage	36V/48V	60V/72V	36V/48V	60V/72V
Maximum Operating Voltage	69V	90V	69V	90V
Minimum Operating Voltage	20V	31V	20V	31V
Peak Current (Armature/Field)	400A/50A	400A/50A	550A/50A	550V/50A
Armature Boost Current (up to 10 sec)	480A	480A	650A	650A
Armature Cont Current (60 min)	150A	150A	170A	170A

## Integrated I/O

Gen4 includes a fully integrated set of inputs and outputs (I/O) with vehicle control functionality, designed to handle a wide range of system requirements and functions. This frequently eliminates the need for additional external I/O modules, vehicle control units and connectors.

- Up to 8 digital inputs
- Up to 3 analogue input
- Up to 4 contactor drivers
- Dedicated 5V, 200mA output
- Dedicated 10V, 200mA output
- Single channel and AB speed encoders
- Motor temperature sensor input

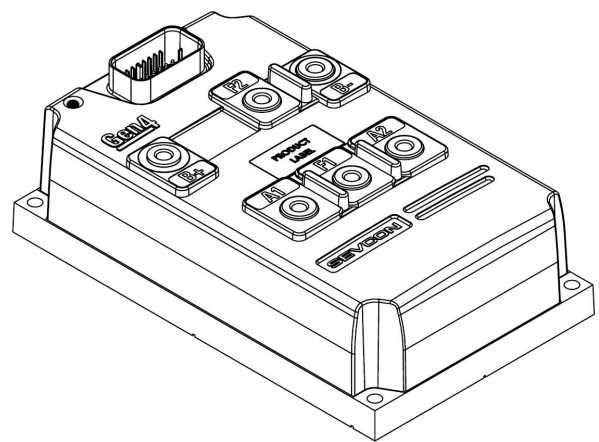

227mm (L) x 138mm (W) x 73mm (H), weight 2 kg

## Other Features

- A CANopen bus allows easy interconnection of controllers and devices such as displays and driver controls.
- The CANbus allows the user to wire the vehicle to best suit vehicle layout since inputs and outputs can be wired to any node on the vehicle and accessed from any controller over the CAN network.
- The Gen4 controller can dynamically change the allowed battery current by exchanging CAN Messages with a compatible Battery Management System.
- The Gen4 is configurable as a vehicle control master controller or simply as a motor slave receiving torque or speed demand over the CANBus and can be used in conjunction with AC motor controllers on the vehicle if desired.

## Configuration Tools

Sevcon offers a range of configuration tools for the Gen4, ranging from PC based software with CAN connection dongle to our Calibrator handset unit. These tools provide a convenient and powerful means of accessing the Gen4 for diagnostic information or parameter adjustment. The handset features password protected access levels and a customized logo start-up screen is possible.



For more  
information visit  
[sevcon.com](http://sevcon.com)