

Gen4  
Size 2 Size 4  
Size 6

## AC Motor Controller

The Gen4 range represents the latest design in compact AC Controllers. These reliable controllers are intended for on-road and off-road electric vehicles and feature the smallest size in the industry for their power capacity.

Thanks to the high efficiency it is possible to integrate these controllers into very tight spaces without sacrificing performance. The design has been optimised for the lowest possible installed cost while maintaining superior reliability in the most demanding applications.

## Features

- Advance flux vector control
- Autocheck system diagnostic
- Integrated logic circuit
- Hardware & software failsafe watchdog operation
- Supports both PMAC and AC motor
- Induction motor control
- Integrated fuse holder
- IP66 protection



## Key Parameters

Model	Size 2	Size 4	Size 6	Size 2	Size 4	Size 6	Size 2	Size 4	Size 6	Size 2*	Size 4
Nominal Battery Voltage	24 VDC	24 to 36 VDC		36 to 48 VDC			72 to 80 VDC			96 to 120 VDC	
Max. operating Voltage	34.8 VDC	52.2 VDC		69.6 VDC			116 VDC			150 VDC	
Min. operating Voltage	12.7 VDC			19.3 VDC			39.1 VDC			48 VDC	
Peak Current (2 min)	300A	450A	650A	275A	450A	650A	180A	350A	550A	150A	300A
Boost Current (10 sec)	360A	540A	780A	330A	540A	780A	215A	420A	660A	180A	360A
Cont. Current (60 min)	120A	180A	260A	110A	180A	260A	75A	140A	220A	60A	120A

\* Not yet available. Please contact Sevcon

## Multiple Motor Feedback Options

Gen4 provides a number of motor feedback possibilities from a range of hardware inputs and software control, allowing a great deal of flexibility.

- Absolute UVW encoder input
- Absolute Sin/Cos encoder input
- Incremental AB encoder input

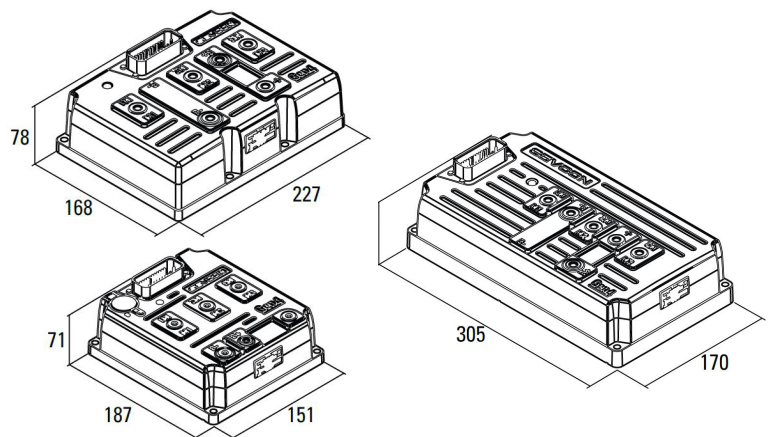

## Integrated I/O

Gen4 includes a fully-integrated set of inputs and outputs (I/O) designed to handle a wide range of vehicle requirements. This eliminated the need for additional external I/O modules or vehicle controllers and connectors.

- 8 digital inputs
- 2 analogue inputs (can be configured as digital)
- 3 contactor/solenoid outputs
- 1 encoder supply output - programmable 5V or 10V

## Other Features

- A CANopen bus allows easy interconnection of controllers and devices such as displays and driver controls
- The CANbus allows the user to wire the vehicle to best suit vehicle layout since inputs and outputs can be connected to any of the controllers on the vehicle and the desired status is passed over the CAN network to the relevant motor controller
- The Gen4 controller can dynamically change the allowed battery current by exchanging CAN messages with a compatible Battery Management System
- Configurable as vehicle control master or motor slave

## Configuration Tools

Sevcon offers a range of configuration tools for the Gen4 controller, with options for Windows based PC or calibrator handset unit. These tools provide a simple yet powerful means of accessing the CAN-open bus for diagnostics or parameter adjustment. The handset unit features password protected access levels and a customized logo start-up screen.



For more information visit [sevcon.com](http://sevcon.com)