

Curtis 1206-03, -04

This sheet is provided to aid in the installation of your remanufactured CURTIS controller. Upon installation, you may encounter problems that may, or may not, be due to a faulty controller. The following steps must be taken to help diagnose a possible cart fault or faulty controller. An analog or digital volt ohm meter (VOM) will be needed to perform these checks.

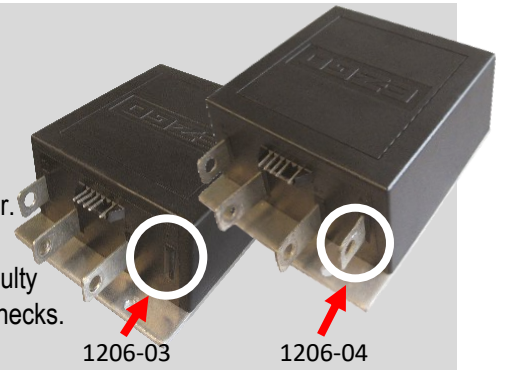

WARRANTY WILL BE VOID **If These Steps are Not Performed Before Installing The Control**

➔ STEPS TO PERFORM *BEFORE* CONTROL INSTALLATION ←

CHECK MOTOR WINDINGS:

- Set your VOM to RESISTANCE (Ω).
- To test the resistance of VOM leads, please touch the meter leads together.
Subtract this measurement from each test below to get your true measurement.
- With motor disconnected, measure A1 to A2. This should measure approximately BETWEEN $.2\Omega$ and 2Ω .
- With motor disconnected, measure F1 to F2. This should measure approximately BETWEEN $.8\Omega$ and 3Ω .
- With motor disconnected, measure A1 to F1. This should measure OPEN.
- With motor disconnected, measure F1 to motor case. This should measure greater than $5M\Omega$.

CHECK MAIN SOLENOID:

- Disconnect all wires from the main solenoid.
- Set your VOM to RESISTANCE (Ω).
- Measure the solenoid coil. This should measure 100Ω - 250Ω (depending on solenoid type).
- Connect VOM leads to the main solenoid lugs.
- Attach jumpers from the main battery positive and negative to the coil (small terminals).
- Meter must jump from infinity to LESS THAN $.3\Omega$.
- Remove jumpers and reconnect solenoid wiring from the harness. (If suppression diode is present, The non-banded side must go the black wires – from B- and backup beeper. Be sure to check diode functionality with VOM prior to install.)

CHECK COTHERM:

- Inspect the cotherm (insulating material) mounted to the heat sink for holes, debris, and tears.
- Repair or replace, if necessary.

CHECK THE CART WIRE HARNESS:

- Check the connectors on the wire harness for corrosion, loose, broken, burnt or missing pins.
- Repair or replace pins as necessary.

**IF ANY OF THE ABOVE ITEMS ARE NOT WITHIN THE SPECIFIED RANGES THE CONTROLLER WILL FAIL.
THESE ITEMS MUST BE CORRECTED BEFORE THE CONTROLLER IS INSTALLED OR WARRANTY WILL BE VOID.**

It is recommended to replace your solenoid at the time of controller replacement. FSIP now stocks popular replacement White Rodgers solenoids for your convenience.

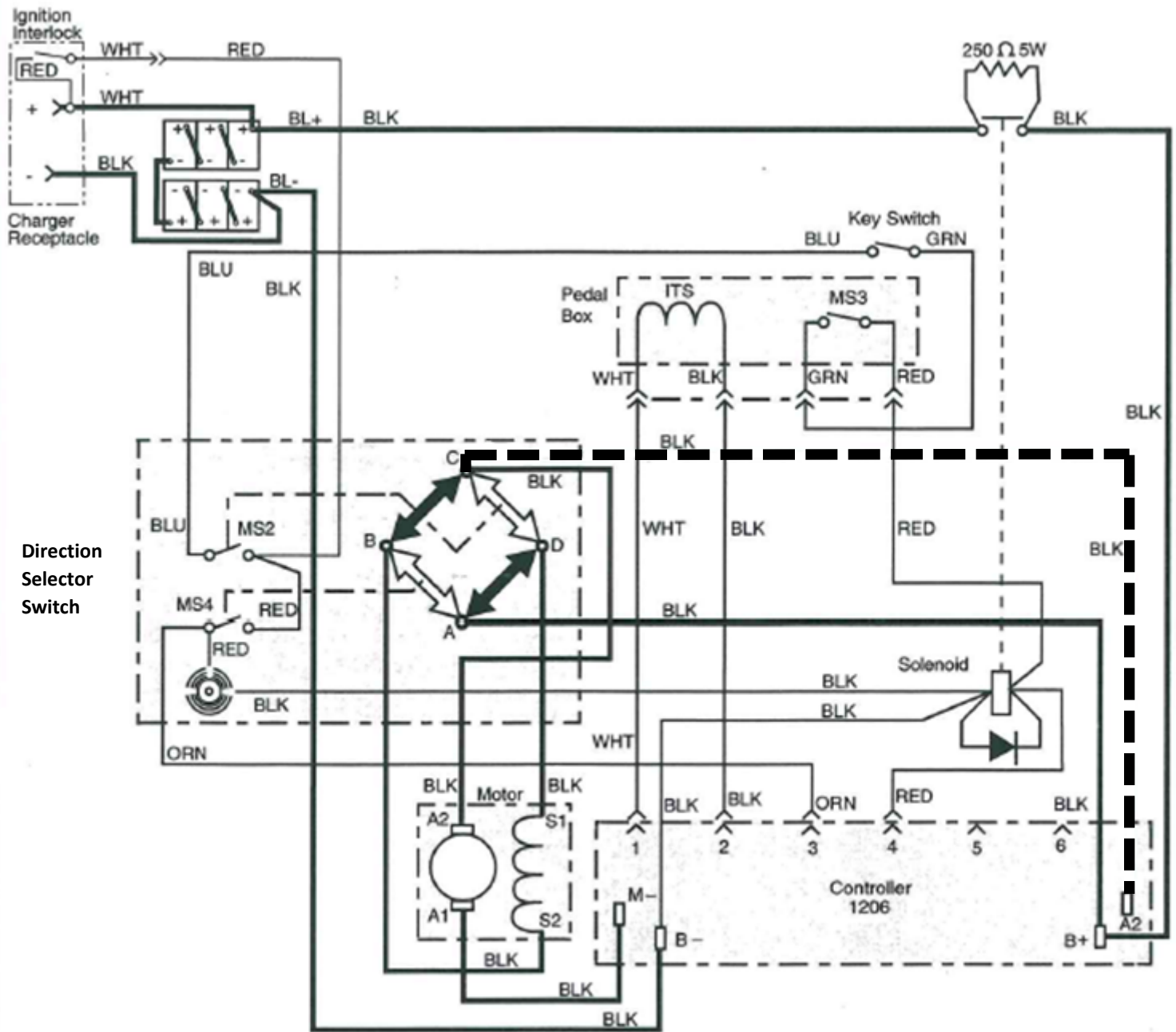

Wires indicated **—————** are contained in power harness

All other wires are control wiring

MS2 is closed when direction selector switch is in forward or reverse

MS3 is activated by accelerator pedal

MS4 is closed by direction selector switch in reverse only

————— This cable is only used with 1206-04 (from Forward/Reverse post C to controller A2 terminal). Not used on 1206-03.

E-Z-GO TXT (Non-PDS) Troubleshooting Sequence

FOR SAFETY, ALWAYS LIFT THE DRIVE WHEELS OFF THE GROUND WHEN TROUBLESHOOTING!

THE FOLLOWING TESTS ARE CONDUCTED WITH A GOOD BATTERY PACK VOLTAGE MEASUREMENT. ALSO, THE CONNECTOR MUST BE ATTACHED TO THE CONTROLLER WHEN MAKING THESE CHECKS. YOU WILL NEED TO 'BACK PROBE' THE PINS FROM THE WIRE SIDE OF THE CONNECTOR. USE A PAPERCLIP IF NECESSARY.

Attach Voltmeter Negative (-) lead to main Battery Negative (-) for the following tests.

Use the following sequence when checking individual pins (don't skip steps). **If you find a fault, do not move on to the next step until the fault is corrected:**

- Measure the voltage at the main battery positive post (let's call it Pack Voltage)
- Pin 4** *With Direction Selector Switch in Forward, Key Switch On, and Pedal down*, must be pack voltage (and solenoid must click)
 - *If not pack voltage, check charger interlock (reed) switch in charger receptacle, micro switch 2 (MS2) in the Direction Selector Switch, Key Switch, Pedal Switch (MS3), and wiring for an open condition*
 - *If pack voltage at pin 4, but solenoid does not click, verify pack volts across solenoid small terminals. Repair open wires or replace solenoid, if necessary*
- Pin 3** *With Direction Selector Switch in Forward, Key Switch On, and Pedal down*, must be 0 volts
 - *If not, check micro switch 4 (MS4) for a shorted condition*
- Pin 3** *With Direction Selector Switch in Reverse, Key Switch On, and Pedal down*, must be pack voltage and backup beeper should beep
 - *If not, check micro switch 4 (MS4) for an open condition*
 - *If pack voltage, but beeper does not beep, verify backup beeper is attached. Replace if necessary*
- Pin 2** *With Direction Selector Switch in Forward, Key Switch On, and Pedal pressed enough to make solenoid click*, must be approximately 12-16V voltage
 - *If not, remove ITS sensor (black wire) and recheck. If voltage returns to 12-16V, replace ITS sensor. If voltage remains below 12V, replace controller*
- Pin 1** *With Direction Selector Switch in Forward, Key Switch On, and Pedal pressed enough to make solenoid click*, must be approximately .6V (+/- .2V)
 - *If not, check wiring between ITS and pin 1. If wiring is good, replace ITS*
- Pin 1** *With Direction Selector Switch in Forward, Key Switch On, and Pedal fully depressed*, must be approximately 1.6V (+/- .2V)
 - *If not, check wiring between ITS and pin 1. If wiring is good, replace ITS*

Continued on next page ...

Helpful Hints

- DO NOT UNDER ESTIMATE THE IMPORTANCE OF MOTOR RESISTANCE CHECKS AND MAIN SOLENOID CHECKS. MANY CART ISSUES ARE CAUSED BY BURNT OR DAMAGED BRUSHES THAT WILL BE FOUND AS PART OF THE ARMATURE RESISTANCE CHECK. ALSO A SHORTED ARMATURE AND FIELD WITHIN THE MOTOR WILL DAMAGE THIS CONTROLLER.

Flight Systems Industrial Products also offers the following Technical Support options ...



Troubleshooting Manuals / Codes
www.shop.fsip.biz/en/content/technical-documents

Live Tech Support Chat
www.fsip.biz



Technical Support Forum
Fsip.websitetoolbox.com

Phone Support
1-800-333-1194 (Option 4)

**PRE-INSTALLATION
INSTRUCTIONS MUST BE
FOLLOWED OR
WARRANTY WILL BE VOID**

**IMPORTANT! E-Z-GO TXT (NON-PDS)
TROUBLESHOOTING INFORMATION
INCLUDED IN THIS PACKET**