

---

# MANUAL

---

---

MODEL **1254**

**HYDRAULIC SYSTEM  
CONTROLLER**

---

© 2011 CURTIS INSTRUMENTS, INC.

1254 Manual, p/n 36374  
Rev. B: February 2011



**CURTIS INSTRUMENTS, INC.**

200 Kisco Avenue  
Mt. Kisco, New York 10549 USA  
Tel. 914.666.2971  
Fax 914.666.2188

[www.curtisinstruments.com](http://www.curtisinstruments.com)



# CONTENTS

1. OVERVIEW .....	1
2. INSTALLATION AND WIRING.....	4
Mounting the Controller .....	4
Connections: Low Current.....	6
Connections: High Current .....	7
Wiring: Standard Configuration for Series Motors.....	8
Wiring: Standard Configuration for Separately Excited Motors .....	10
Wiring: Throttles .....	12
5kΩ–0, 2-wire pot (“Type 1”).....	13
Single-ended 0–5V, current source, 3-wire pot, and electronic throttles (“Type 2”) .....	14
0–5kΩ, 2-wire pot (“Type 3”).....	16
Wigwag-style 0–5V and 3-wire pot throttles (“Type 4”) .....	17
CAN-Nodes throttle (“Type 5”).....	18
Wiring: Fault Outputs .....	18
Wiring: Hour Meter .....	18
Wiring: CAN Bus Interface .....	18
Contactor, Switches, and Other Hardware.....	19
3. PROGRAMMABLE PARAMETERS .....	21
Speed Select Parameters .....	23
Maximum Speed, SS1–SS6 .....	23
Minimum Speed.....	23
Minimum Speed Disable.....	23
Speed Select Acceleration Rate.....	23
Speed Select Deceleration Rate.....	23
Throttle Parameters.....	24
Throttle Type .....	24
Lift Maximum Speed, Throttle 1.....	24
Lower Maximum Speed, Throttle 1.....	25
Maximum Speed, Throttles 2-3.....	25
Throttle Acceleration Rate.....	26
Throttle Deceleration Rate.....	26
Throttle Deadband.....	26
Throttle Maximum .....	28
Throttle Map.....	30

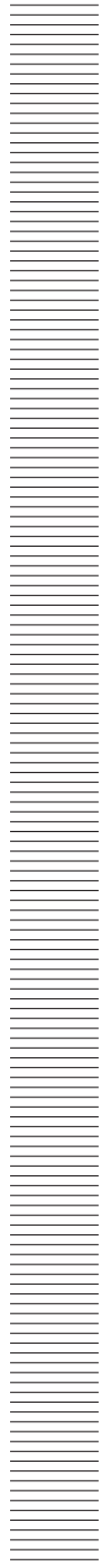

Final Speed Request Parameters .....	32
Multifunction .....	32
Add Mode, SS1–SS6 .....	32
Throttle Add Mode .....	33
Final Add Mode .....	33
Fault Parameters .....	34
Throttle Fault, Throttles 1-3 .....	34
Lift Lockout .....	34
Startup Lockout .....	34
Fault Code .....	35
Pump Contactor Driver Parameters .....	36
Pump Contactor Control .....	36
Pump Contactor Dropout Delay .....	36
Sequencing Delay .....	37
Pump Contactor Diagnostics .....	37
Valve Parameters .....	37
Proportional Valve Gain .....	37
Valve Control .....	38
Coil Check .....	39
Proportional Valve Maximum Current .....	39
Proportional Valve Minimum Current .....	39
Proportional Valve Dither .....	39
Proportional Valve Acceleration Rate .....	39
Proportional Valve Deceleration Rate .....	40
Load Hold Delay .....	40
Other Parameters .....	40
Current Limit .....	40
Battery Voltage .....	40
Current Ratio .....	41
Precharge .....	41
Load Compensation .....	42
Field Control Parameters	
<i>(for Separately Excited Motor Applications Only)</i> .....	42
Sepex Option .....	42
Maximum Field Current Limit .....	42
Minimum Field Current Limit .....	42
Field Map Start .....	42
Field Map .....	43
CAN-Nodes Parameters	
<i>(for CAN-Nodes Control Systems Only)</i> .....	44
Nodes Option .....	44
Node Address .....	44

4. INSTALLATION CHECKOUT .....	45	=====
5. PROGRAMMER OPERATION .....	48	=====
Programmer Operating Modes.....	50	=====
Peace-of-Mind Programming .....	52	=====
Programmer Menus .....	54	=====
6. DIAGNOSTICS AND TROUBLESHOOTING.....	59	=====
Programmer Diagnostics .....	59	=====
LED Diagnostics.....	61	=====
Fault Output Drivers .....	62	=====
7. MAINTENANCE .....	63	=====
Cleaning .....	63	=====
Diagnostic History.....	63	=====
<b>APPENDIX A</b> Glossary of Features and Functions.....	A-1	=====
<b>APPENDIX B</b> Throttle Mounting Dimensions.....	B-1	=====
<b>APPENDIX C</b> Electromagnetic Compatibility (EMC) .....	C-1	=====
<b>APPENDIX D</b> Speed Conditioning Diagrams .....	D-1	=====
<b>APPENDIX E</b> Curtis WEEE / RoHS Statement.....	E-1	=====
<b>APPENDIX F</b> Specifications .....	F-1	=====

## FIGURES

FIG. 1:	Curtis 1254 hydraulic system controller.....	1
FIG. 2:	Mounting dimensions, Curtis 1254 controller .....	4
FIG. 3:	Standard wiring configuration, for series motor applications.....	8
FIG. 4:	Standard wiring configuration, for separately excited motor applications.....	10
FIG. 5:	Wiring for 5k $\Omega$ -0 potentiometer (“Type 1”) .....	13
FIG. 6:	Wiring for 0-5V voltage sources (“Type 2”) .....	14
FIG. 8:	Wiring for 3-wire potentiometer (“Type 2”) .....	15
FIG. 7:	Wiring for current source (“Type 2”) .....	15
FIG. 9:	Wiring for Curtis ET-XXX (“Type 2”) .....	16
FIG. 10:	Wiring for 0-5k $\Omega$ potentiometer (“Type 3”) .....	17
FIG. 11:	Wiring for fault outputs.....	18
FIG. 12:	Lift/Lower hydraulic system diagram .....	25
FIG. 13:	Effect of adjusting the throttle deadband parameter .....	26, 27
FIG. 14:	Effect of adjusting the throttle max parameter .....	28, 29
FIG. 15:	Throttle maps for controller with maximum speed set at 100% .....	31
FIG. 16:	Throttle maps for controller with maximum speed set at 80% .....	31
FIG. 17:	Influence of various parameters on controller output response to throttle demand .....	31
FIG. 18:	Field current relative to armature current, with field map parameter set at 50% and 25% .....	43
FIG. 19:	Bench testing with the 1309 programmer.....	47

FIG. B-1: Mounting dimensions, Curtis standard  
5k $\Omega$ , 3-wire throttle pot.....B-1

FIG. B-2: Mounting dimensions, Curtis potboxes .....B-1

FIG. B-3: Mounting dimensions, Curtis throttle WP-45 CP .....B-2

FIG. B-4: Mounting dimensions, Curtis electronic throttle.....B-2

FIG. D-1: Speed conditioning diagram, basic configuration ..... D-2

FIG. D-2: Speed conditioning diagram, with multifunction  
control handle ..... D-3

## TABLES

TABLE 1: Throttle wiper input (threshold values) ..... 12

TABLE 2: Programmable throttle input signal types ..... 24

TABLE 3: Fault categories ..... 35

TABLE 4: Programmable pump contactor control types ..... 36

TABLE 5: Troubleshooting chart..... 60

TABLE 6: Status LED fault codes ..... 61

TABLE 7: Fault category codes ..... 62

TABLE F-1: Specifications, 1254 controller ..... F-1





## 1

## OVERVIEW

Curtis 1254 motor controllers are specifically designed for use with high power pump motors. They provide finer control than traction motor controllers that have been adapted for pump motor control. Typical applications include the hydraulic systems of material handling vehicles (stackers, reach trucks), man-up platforms (scissor lifts, articulating/telescoping booms), and other industrial vehicles.

**Fig. 1** *Curtis 1254 hydraulic system controller.*



The 1254 controller offers smooth, silent, cost effective control of motor speed and torque. The standard model is intended for use with series motors. If desired, the controller can be factory-configured for use with separately excited motors. The 1254 controller can also be factory-configured to be compatible with CAN Bus communication systems.

In addition to controlling the pump motor, the 1254 controls the valves on the Lift cylinder's hydraulic line. By so doing, it controls the hydraulic path for Lift and Lower operations. The hydraulic path for any other hydraulic operations—e.g., reach, tilt, sideshift, rotate—is provided by the vehicle manufacturer, with the 1254 controlling the pump motor speed but not the hydraulic path itself.

These controllers are fully programmable by means of the optional hand-held 1307 programmer. Use of the programmer provides diagnostic and test capability as well as configuration flexibility.

Like all Curtis motor controllers, the 1254 offers superior operator control of the motor speed. Features include:

- ✓ Programmability through the 1307 handheld programmer
- ✓ Three throttle inputs for single-ended or wigwag 5k $\Omega$  pots or 0–5V throttles (both standard full stroke and restricted range)
- ✓ Programmable throttle map for throttle inputs
- ✓ Six Speed Select inputs
- ✓ Independently programmable top speed for each Speed Select and throttle input
- ✓ Programmable minimum speed setting for maintaining steering system pressure and lubrication
- ✓ Lowering operations start smoothly, because of hydraulic system pre-load function
- ✓ Continuous armature current control, reducing arcing and brush wear
- ✓ Complete diagnostics through the 1307 programmer and the controller's built-in Status LED
- ✓ Two fault outputs provide diagnostics to remotely mounted displays
- ✓ Linear cutback on motor currents during overtemperature maintains auxiliary functions
- ✓ Undervoltage protection feature maintains lift capacity, but causes a linear cutback in output voltage
- ✓ Startup Lockout feature prevents inadvertent Lift or Lower (or any auxiliary function) at startup
- ✓ Load-hold valve is controlled by a dedicated driver
- ✓ Proportional lowering valve is controlled by a variable current driver, for precise control during lowering
- ✓ Active precharge of controller capacitor bank extends life of pump contactor tips
- ✓ Hour-meter enable output is active whenever the controller is providing motor current
- ✓ Meets EEC fault detection requirements (standard M- PWM fault check), provided the pump contactor control feature is not programmed Off.

- ✓ ISO 7176 compliant fault detection circuitry on all three throttle inputs inhibits operation if throttle pot signal goes out of range for any reason
- ✓ Continuous diagnostics during operation, with microprocessor power-on self-test
- ✓ Positive battery connections for all inputs
- ✓ Output drivers are short-circuit protected and provide built-in coil spike protection
- ✓ Fully protected inputs
- ✓ Internal and external watchdog circuits ensure proper software operation
- ✓ Can be factory-configured for use with separately excited motors; separately excited motor control provides improved loaded lift speeds *[OPTIONAL]*
- ✓ Can be factory-configured for CAN Bus compatibility *[OPTIONAL]*.

Familiarity with your Curtis controller will help you install and operate it properly. We encourage you to read this manual carefully. If you have questions, please contact the Curtis office nearest you.

## 2

## INSTALLATION AND WIRING

## MOUNTING THE CONTROLLER

The 1254 controller can be oriented in any position, and meets the IP64/IP67 ratings for environmental protection against dust and water. However, **the location should be carefully chosen to keep the controller clean and dry. If a clean, dry mounting location cannot be found, a cover must be used to shield the controller from water and contaminants.**

The outline and mounting hole dimensions for the 1254 controller are shown in Figure 2. When selecting the mounting position, be sure to also take into consideration (1) that access is needed at the top of the controller to plug the programmer into its connector, and (2) that the built-in Status LED is visible only through the view port in the label on top of the controller.

**Fig. 2** *Mounting dimensions, Curtis 1254 controller.*

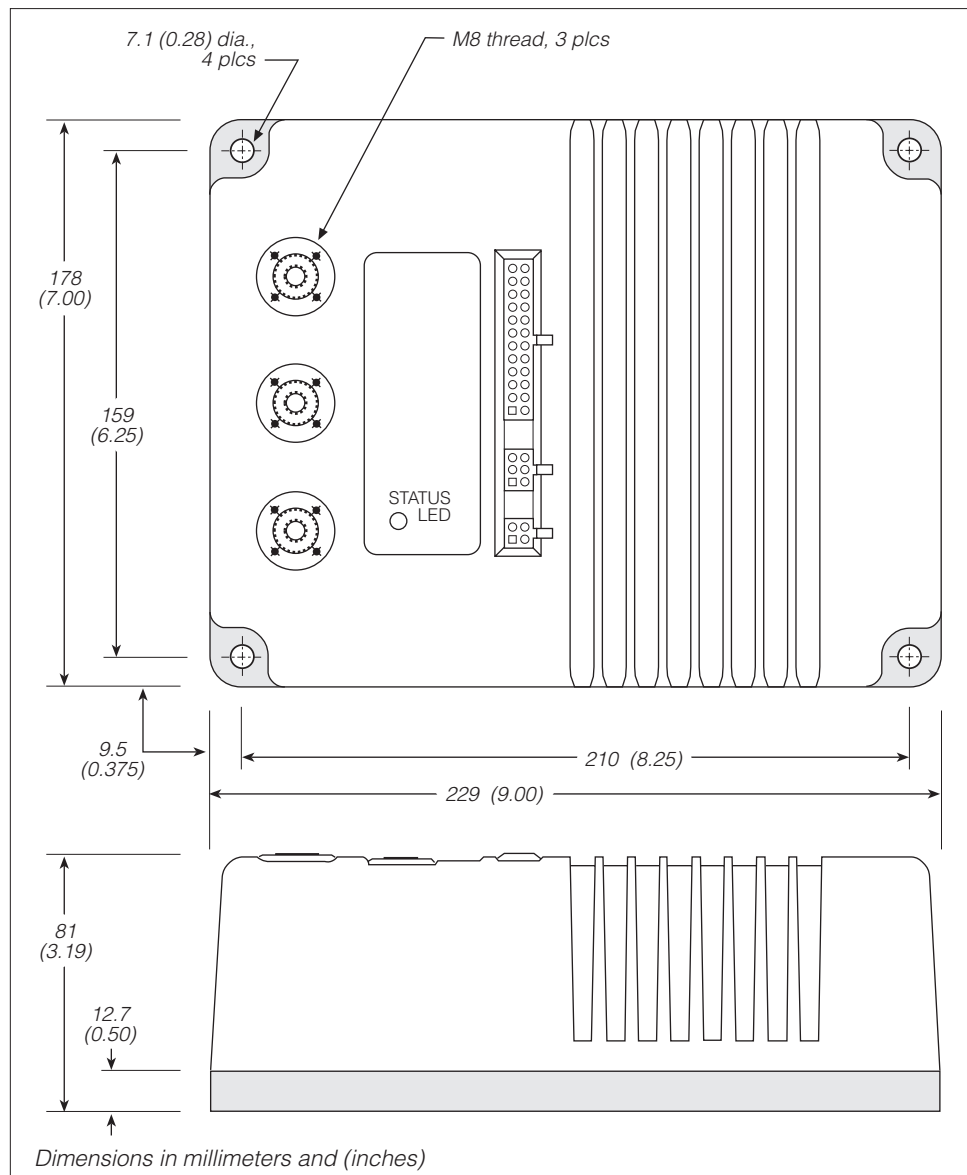

To ensure full rated power, the controller should be fastened to a clean, flat metal surface with four 6 mm (1/4") diameter screws, using the holes provided. Although not usually necessary, a thermal joint compound can be used to improve heat conduction from the controller heatsink to the mounting surface. You will need to take steps during the design and development of your end product to ensure that its EMC performance complies with applicable regulations; suggestions are presented in Appendix C.



**Working on electrical systems is potentially dangerous.** You should protect yourself against uncontrolled operation, high current arcs, and outgassing from lead acid batteries:

**UNCONTROLLED OPERATION** — Some conditions could cause the hydraulic system to run out of control. Disconnect the motor or make sure the hydraulic system has enough room to operate before attempting any work on the motor control circuitry. NOTE: If the wrong throttle input signal type is selected with the handheld programmer, the hydraulic system may suddenly begin to operate.

**HIGH CURRENT ARCS** — Batteries can supply very high power, and arcing can occur if they are short circuited. Always open the battery circuit before working on the motor control circuit. Wear safety glasses, and use properly insulated tools to prevent shorts.

**LEAD ACID BATTERIES** — Charging or discharging generates hydrogen gas, which can build up in and around the batteries. Follow the battery manufacturer's safety recommendations. Wear safety glasses.

## CONNECTIONS

### Low Current Connections

Three low current connectors are built into the 1254 controller. They are located in a row on the top of the controller:

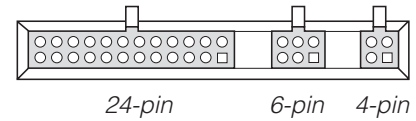

The 24-pin connector provides the logic control connections. The mating connector is a 24-pin Molex Mini-Fit Jr. connector part number 39-01-2245 using type 5556 terminals.

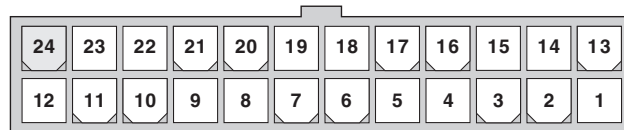

<b>Pin 1</b>	keyswitch input (KSI)
<b>Pin 2</b>	interlock input
<b>Pin 3</b>	Lift input
<b>Pin 4</b>	Lower input
<b>Pin 5</b>	Fault 1 output
<b>Pin 6</b>	Fault 2 output
<b>Pin 7</b>	Speed Select 1 input
<b>Pin 8</b>	Speed Select 2 input
<b>Pin 9</b>	Speed Select 3 input
<b>Pin 10</b>	Speed Select 4 input
<b>Pin 11</b>	Throttle 1 (Lift/Lower) input
<b>Pin 12</b>	hour meter enable output
<b>Pin 13</b>	Throttle 2 input
<b>Pin 14</b>	Pot Low output
<b>Pin 15</b>	Throttle 3 input
<b>Pin 16</b>	Speed Select 5 input
<b>Pin 17</b>	pump contactor driver output
<b>Pin 18</b>	load hold valve driver output
<b>Pin 19</b>	proportional valve driver output
<b>Pin 20</b>	Speed Select 6 input
<b>Pin 21</b>	Pot High 1 output
<b>Pin 22</b>	Pot High 2 output
<b>Pin 23</b>	Pot High 3 output
<b>Pin 24</b>	[not used]

A 6-pin low power Molex connector is provided for the CAN Bus interface. However, this interface is active only if the CAN Bus option has been specified. The mating connector is a Molex Mini-Fit Jr. p/n 39-01-2065 using type 5556 terminals.

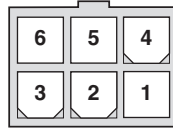

<b>Pin 1</b>	+15V supply (limited to 20 mA)
<b>Pin 2</b>	ground return (B-)
<b>Pin 3</b>	CAN A I/O line
<b>Pin 4</b>	CAN B termination
<b>Pin 5</b>	CAN A termination
<b>Pin 6</b>	CAN B I/O line

The +15V supply should be used only with the CAN system and not to power any other external systems. The A and B terminations provide a  $120\Omega$  termination impedance for the CAN A I/O and CAN B I/O inputs if necessary. Refer to the Curtis CAN Protocol Document to determine the proper termination for a given application.

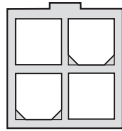

A 4-pin low power connector is provided for the handheld 1307 programmer. A complete programmer kit with the appropriate connecting cable can be ordered:

Curtis p/n 168961101 for the User Programmer (model 1307m-1101)

Curtis p/n 168962101 for the OEM Programmer (model 1307m-2101).

If a programmer is already available but has an incompatible cable, the 1254 mating cable can be ordered as a separate part: Curtis p/n 16185.

### High Current Connections

Three tin-plated solid aluminum bus bars are provided for the high current connections to the battery (**B+** and **B-**) and the motor armature (**M-**). The bus bars incorporate threaded mounting studs designed to accept mounting bolts. This

simplifies the assembly and reduces the mounting hardware necessary for the power connections. The **B+**, **B-**, and **M-** bus bars are threaded to accept M8 bolts to a depth of  $3/4$ ". Controllers factory-configured for use with separately excited motors have a fourth bus bar (**F2**) for the motor field connection. The **F2** bus bar is threaded to accept an M6 bolt to a depth of  $5/8$ ". The tightening torque applied to the bolts should not

exceed 20 N·m (15 ft·lbs) for the M8 bolts or 16.3 N·m (12 ft·lbs) for the M6 bolt. Exceeding these specifications could damage the bus bars' internal threads, resulting in loose connections.

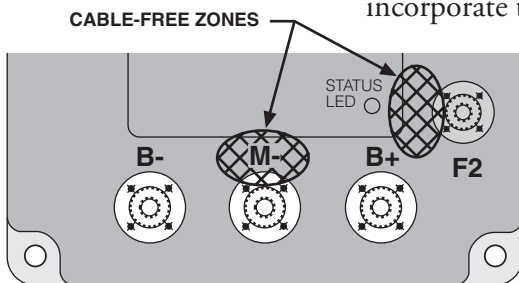

**Power cables must not be routed over the indicated areas.** Otherwise they may interfere with the proper operation of sensitive electromagnetic components located underneath.

### WIRING: Standard Configuration for Series Motors

Figure 3 shows the typical wiring configuration for most applications using series motors. The interlock switch is typically a seat switch, tiller switch, or foot switch.

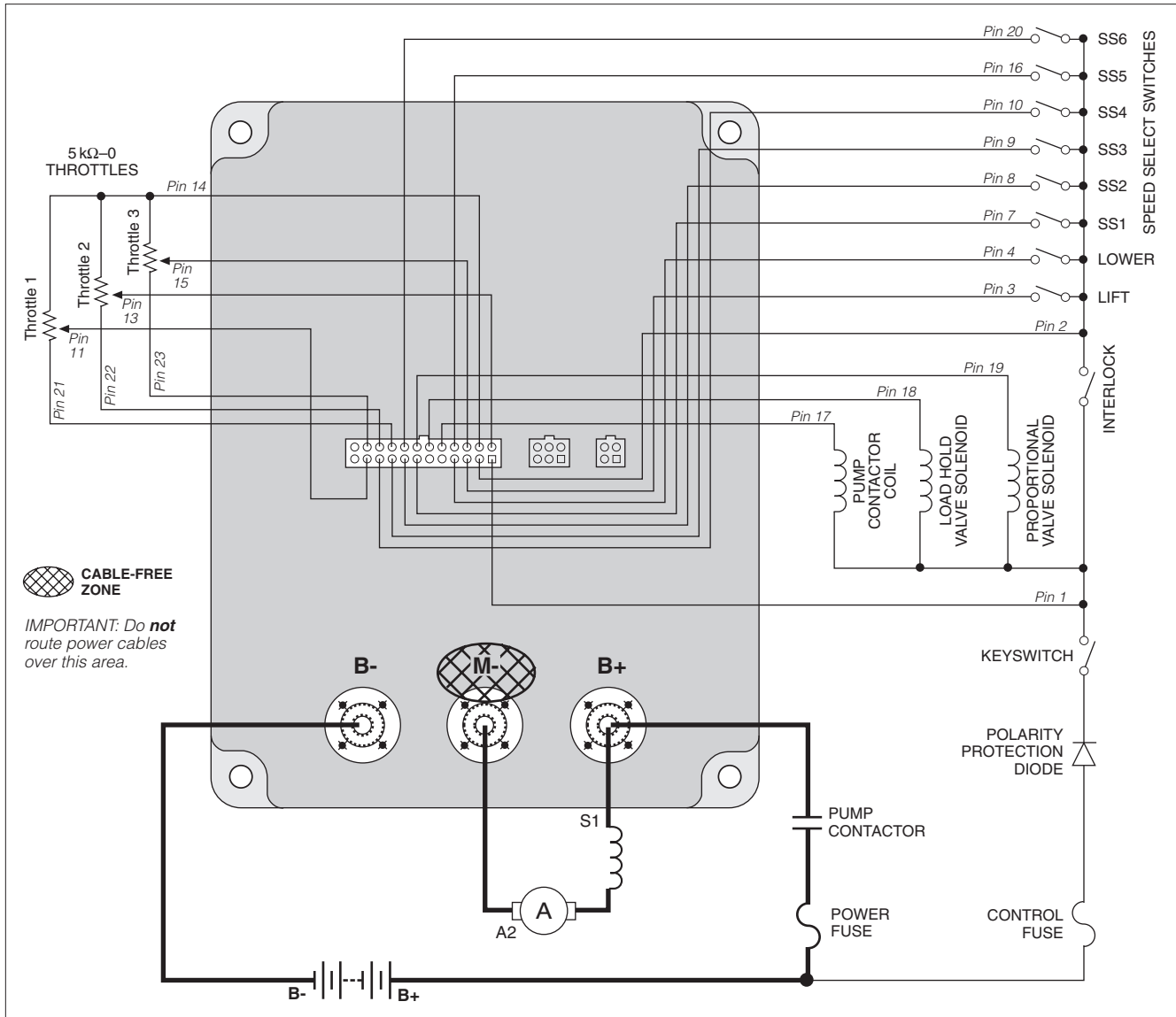

**Fig. 3** Standard wiring configuration, Curtis 1254 controller (series motor).

#### Power Wiring for Series Motors

Series motor wiring is straightforward, with the field's S1 connection going to the controller's **B+** bus bar and the armature's A2 connection going to the controller's **M-** bus bar.

**Power cables must not be routed over the indicated area.** Components adjacent to the **M-** bus bar are sensitive to electromagnetic interference.



### Standard Control Wiring for Series Motors

Wiring for the input switches and contactors is shown in Figure 3; the connector is shown in more detail below. NOTE: Control wiring is the same for series and separately excited motor systems.

24-pin detail (see Fig. 3):

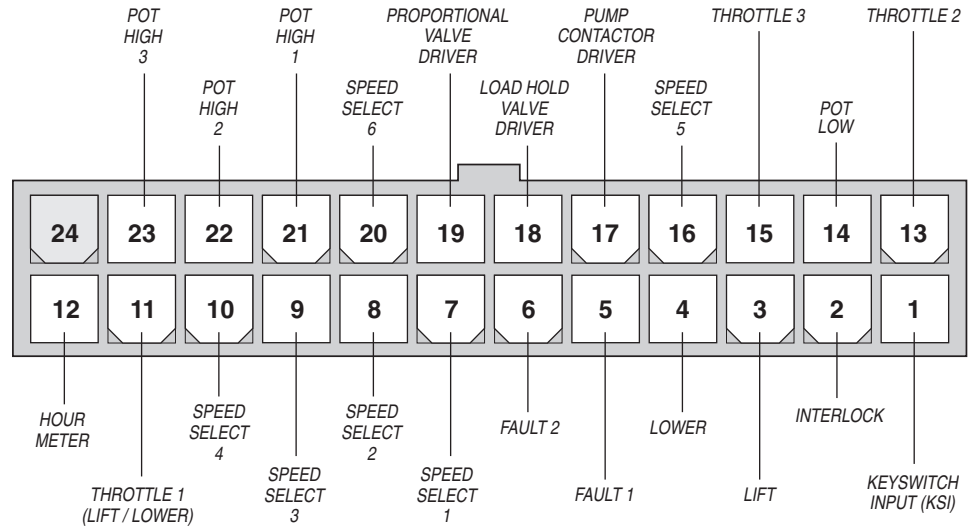

The pump contactor coil should be wired directly to the controller as shown in Figure 3. The controller can be programmed to check for welded or missing pump contactor faults and uses the pump contactor coil driver output to remove power from the controller and motor in the event of various other faults. If the pump contactor coil is not wired to Pin 17, the controller will not be able to open the pump contactor in serious fault conditions.

In the example shown in Figure 3, three 3-wire potentiometers are used (Throttle 1, Throttle 2, and Throttle 3). The 1254 accepts speed control inputs from a variety of throttles; however, all the throttles used together in an application must be of the same type. Throttle 1 is dedicated to the Lift/Lower functions.

Wiring is not shown for the hour meter (Pin 12) or the two fault outputs (Pins 5 and 6) because they are wired independently and thus are not part of the circuits shown in Figure 3.

### WIRING: Standard Configuration for Separately Excited Motors

The 1254 is available in a model designed for use with separately excited motors. This model has a fourth bus bar (**F2**) for connecting to the motor's field winding; it also has extra features that enable it to provide improved loaded lift speeds. Figure 4 shows the typical wiring configuration.

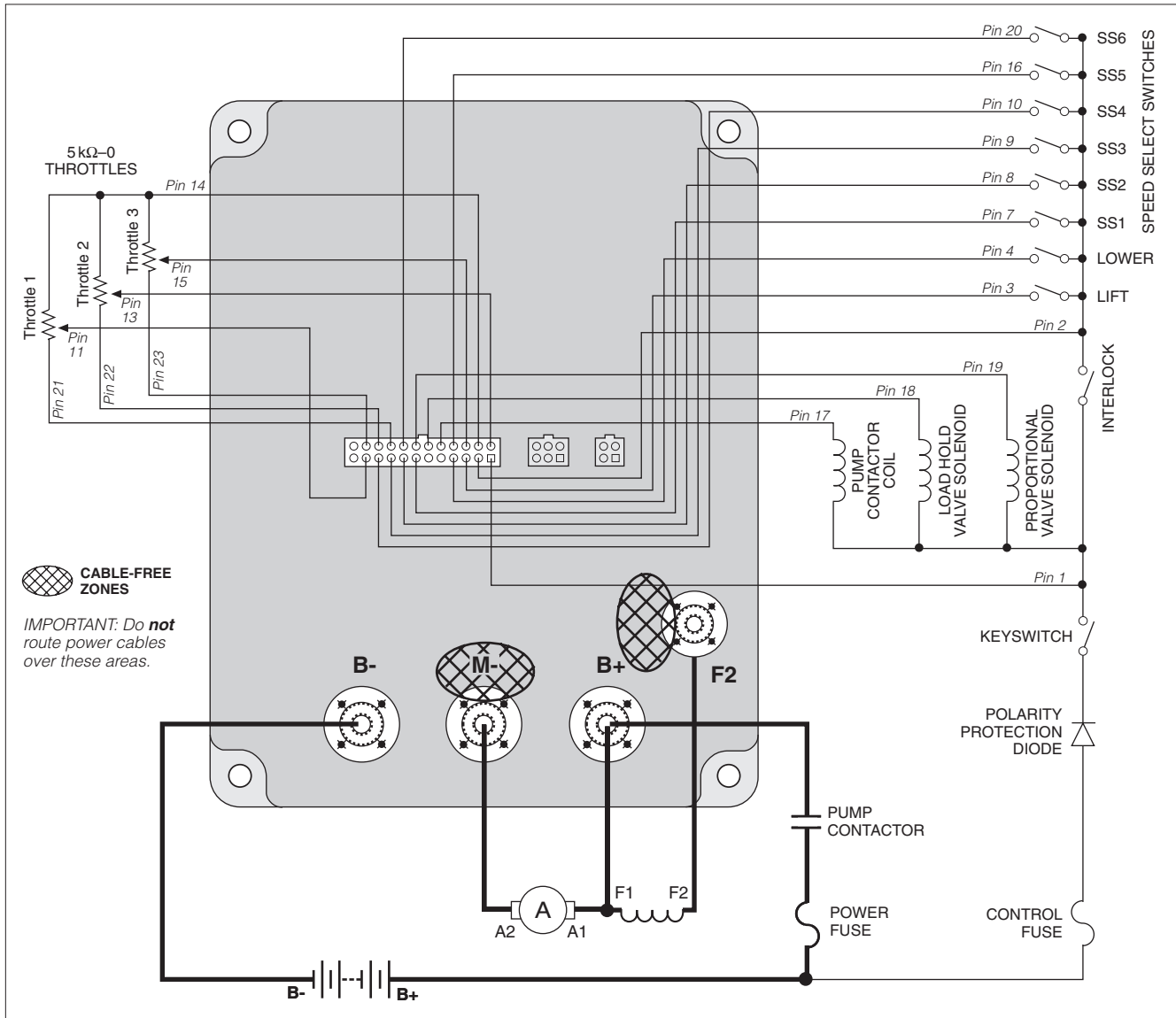

Fig. 4 Standard wiring configuration, Curtis 1254 controller (separately excited motor option).

#### Power Wiring for Separately Excited Motors

Separately excited motor wiring is as shown below, with the field winding's F2 connection going to the controller's **F2** bus bar and its F1 connection going to the controller's **B+** bus bar. The armature's A1 connection also goes to the controller's **B+** bus bar, and the A2 connection to the controller's **M-** bus bar.

**Power cables must not be routed over the indicated areas.** Components adjacent to the **M-** and **F2** bus bars are sensitive to electromagnetic interference.

### Standard Control Wiring for Separately Excited Motors

Wiring for the input switches and contactors is shown in Figure 4; the connector is shown in more detail below. NOTE: Control wiring is the same for series and separately excited motor systems.

24-pin detail (see Fig. 4):

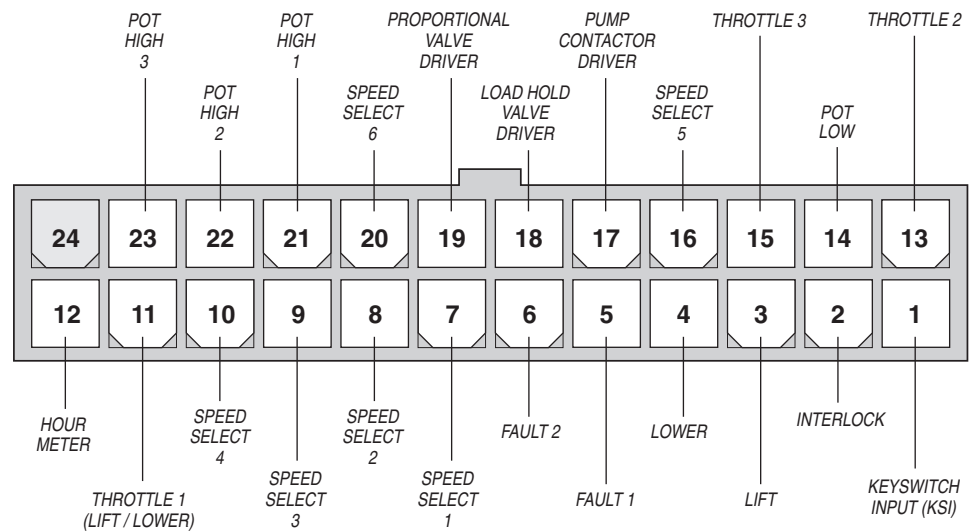

The pump contactor coil should be wired directly to the controller as shown in Figure 4. The controller can be programmed to check for welded or missing pump contactor faults and uses the pump contactor coil driver output to remove power from the controller and motor

In the example shown in Figure 4, three 3-wire potentiometers are used (Throttle 1, Throttle 2, and Throttle 3). The 1254 accepts speed control inputs from a variety of throttles; however, all the throttles used together in an application must be of the same type.

Wiring is not shown for the hour meter (Pin 12) or the two fault outputs (Pins 5 and 6) because they are wired independently and thus are not part of the circuits shown in Figure 4.

## WIRING: Throttles

Various throttles can be used with the 1254 controller. They are categorized as one of five types in the programming menu of the handheld programmer.

Type 1: two-wire 5k $\Omega$ –0 potentiometer throttles

Type 2: 0–5V throttles, current source throttles, three-wire pot throttles, and electronic throttles—wired for single-ended operation

Type 3: two-wire 0–5k $\Omega$  potentiometer throttles

Type 4: 0–5V and three-wire pot throttles—wired for wigwag-style operation

Type 5: CAN-Nodes throttles

Table 1 summarizes the operating specifications for these five throttle types.

NOTE: For Type 2 and Type 4 throttles, the controller reads only voltage at the wiper input—even when potentiometers are used.

**Table 1 THROTTLE WIPER INPUT THRESHOLD VALUES**

THROTTLE TYPE	PARAMETER	MINIMUM THROTTLE FAULT	THROTTLE DEADBAND (0% speed request)	STARTUP LOCKOUT (25% pot active range)	THROTTLE MAX (100% modulation)	MAXIMUM THROTTLE FAULT
1	Wiper Voltage	0.1 V	3.3 V	1.0 V	0.2 V	4.4 V
	Wiper Resistance	—	5.0 k $\Omega$	3.8 k $\Omega$	0 k $\Omega$	7.5 k $\Omega$
2	Wiper Voltage	(none)	0.2 V	1.4 V	5.0 V	5.5 V
	Wiper Resistance	—	—	—	—	—
3	Wiper Voltage	0.1 V	0.2 V	1.0 V	3.3 V	4.4 V
	Wiper Resistance	—	0 k $\Omega$	1.3 k $\Omega$	5.0 k $\Omega$	7.5 k $\Omega$
4	Wiper Voltage	0.50 V	2.5 V (Lift) * 2.5 V (Lower) *	3.1 V (Lift) 1.9 V (Lower)	4.4 V (Lift) 0.6 V (Lower)	4.5 V
	Wiper Resistance	—	—	—	—	—
5	Wiper Voltage	N/A	N/A	N/A	N/A	N/A
	Wiper Resistance	N/A	N/A	N/A	N/A	N/A

Notes: The upper and lower deadbands are valid for nominal 5k $\Omega$  potentiometers or 5V sources with the default Throttle Deadband and Throttle Max parameter settings of 0% and 100% respectively. These values will change with variations in the Throttle Deadband and Throttle Max parameter settings—see Section 3, pages 26 and 28.

The startup lockout threshold is 25% of the active range and is therefore dependent on the programmed Throttle Deadband and Throttle Max settings (which define the active range).

\* With a 0% Throttle Deadband, there is no neutral point on a Type 4 pot. It is recommended that an 8% minimum deadband be used with Type 4 throttles.

For potentiometers, the 1254 provides complete throttle fault protection that meets all applicable EEC regulations. For voltage throttles, the 1254 protects against out-of-range wiper voltages (see Table 1), but does not detect wiring faults; it is therefore the responsibility of the OEM to provide full throttle fault protection in vehicles using voltage throttles.

Up to three separate throttles can be used with the 1254. Because all the throttles will be defined by the same set of parameters, all must be of the same type (see Table 1).

If you use a throttle for lifting/lowering, it should be wired as Throttle 1. If you are using fewer than three throttles, the throttle faults on the unconnected throttle input(s) should be programmed Off—see Section 3.

Wiring for the most common throttles is described below. If the throttle you are planning to use is not covered, contact the Curtis office nearest you.

note: In the text, throttles are identified by their nominal range (e.g.,  $5k\Omega-0$  pot) and not by their actual operating range.

### $5k\Omega-0$ Throttle (“Type 1”)

The  $5k\Omega-0$  throttle (called a “Type 1” throttle in the programming menu of the handheld programmer) is a 2-wire resistive throttle that connects between a pot wiper pin (Throttle 1, 2, or 3 input pin) and the Pot Low output pin, as shown in Figure 5. For Type 1 devices, zero speed corresponds to a nominal  $5k\Omega$  measured between the pot wiper and Pot Low pins and full speed corresponds to  $0\Omega$ .

If the total resistance between a pot wiper input pin and Pot Low output pin is greater than  $7.5k\Omega$ , the controller’s upper fault limit will be exceeded (see Table 1) and that throttle’s input value will be zeroed. This provides broken wire protection, and also serves as an indication that the potentiometer’s resistance has increased beyond the acceptable range and that the pot therefore needs to be replaced.

**Fig. 5** Wiring for  $5k\Omega-0$  throttle (“Type 1”).

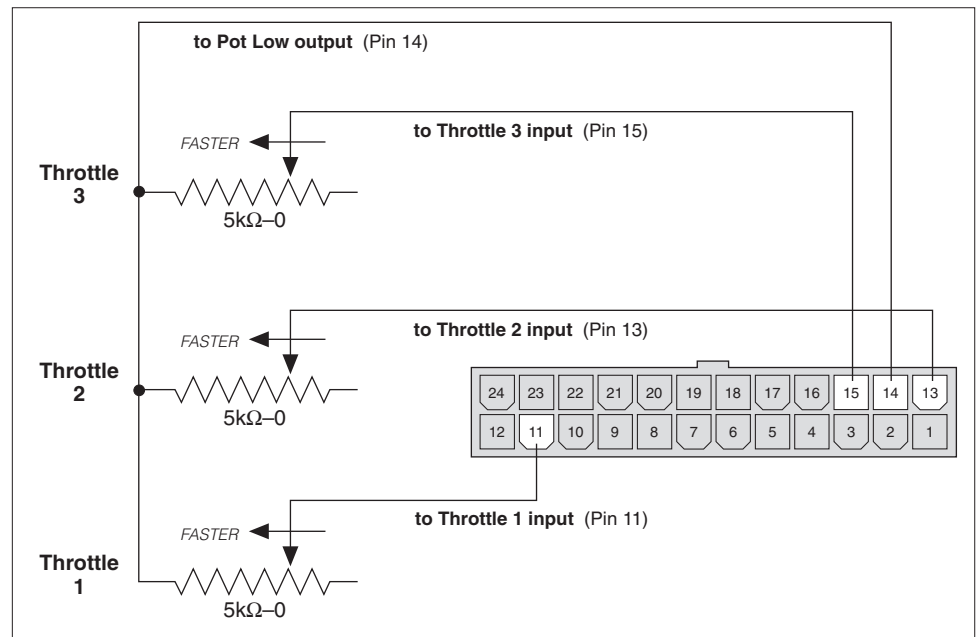

**Single-Ended 0–5V Voltage Source, 3-Wire Pot, Current Source, and Electronic Throttles (“Type 2”)**

With these throttles (“Type 2” in the programming menu) the controller looks for a voltage signal at the wiper input (Throttle 1,2,3). Zero speed corresponds to 0V and full speed to 5V. A variety of devices can be used with this throttle input type, including voltage sources, voltage sensors, current sources, and 3-wire pots.

*0–5V Throttle*

Two ways of wiring the 0–5V throttle are shown in Figure 6. The active range for this throttle is from 0.2V (at 0% Throttle Deadband) to 5.0V (at 100% Throttle Max), measured relative to B-. Signals are measured at the Throttle 1,2,3 inputs. It is the responsibility of the OEM to provide appropriate throttle fault detection for 0–5V throttles.

**Fig. 6** *Wiring for 0–5V throttles (“Type 2”).*

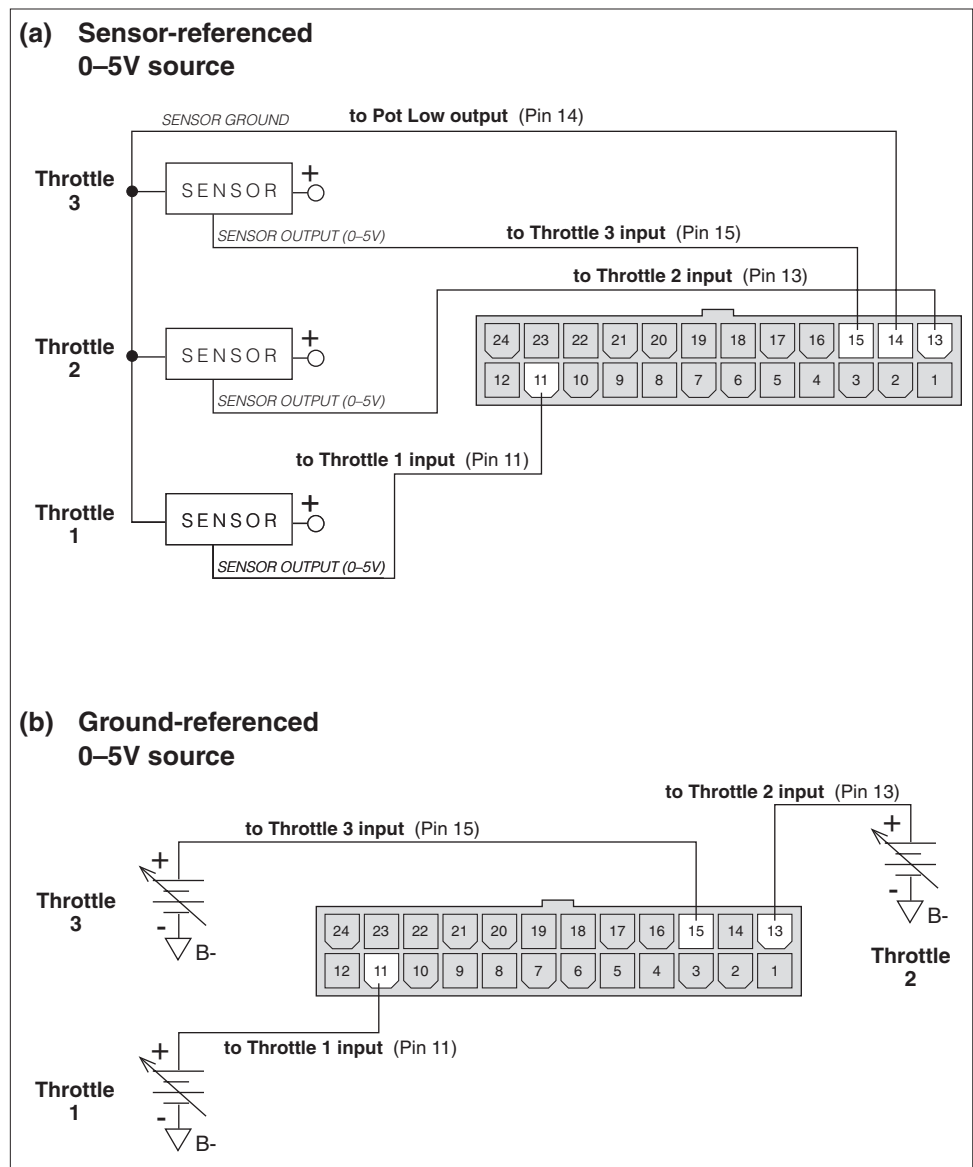

### Current Source Used As a Speed Control Device

A current source can be used as a throttle input as shown in Figure 7. A resistor,  $R_{\text{throttle}}$ , must be used to convert the current source value to a voltage. The resistor should be sized to provide a 0–5V signal variation over the full current range.

It is the responsibility of the OEM to provide appropriate throttle fault detection for current sources used as throttles.

**Fig. 7** Wiring for current source throttle (“Type 2”).

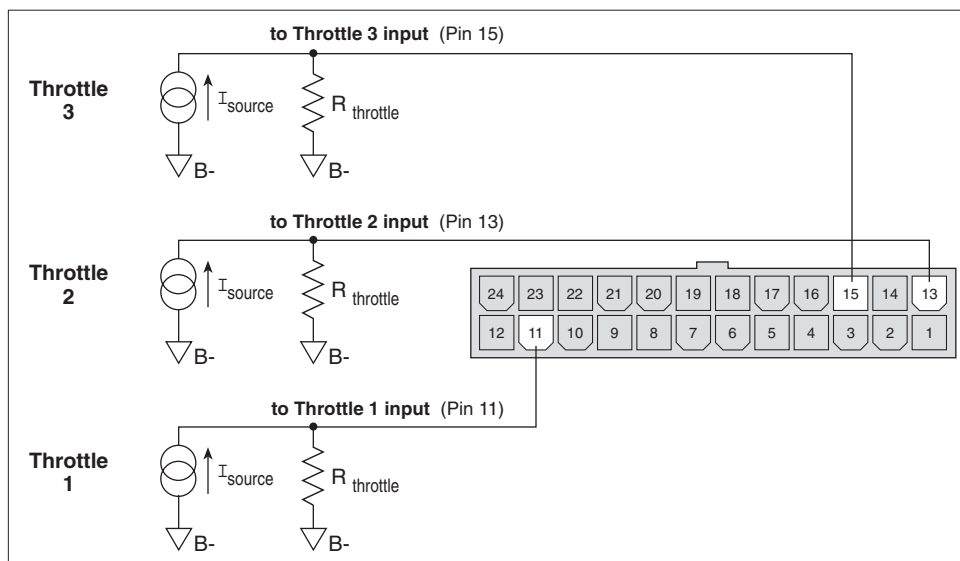

### 3-Wire Pot Throttle ( $1\text{k}\Omega$ – $10\text{k}\Omega$ )

The 3-wire potentiometer is used in its voltage divider mode, with the voltage source and return being provided by the 1254 controller. Pot High provides a current limited 5V source to the pot, and Pot Low (Pin 14) provides the return path. The pot wiper is then connected to a throttle input pin. Wiring is shown in Figure 8 and also in the standard wiring diagrams, Figures 3 and 4.

When a 3-wire pot is used, the controller provides full fault protection. Potentiometers with total resistance values between  $1\text{k}\Omega$  and  $10\text{k}\Omega$  can be used.

**Fig. 8** Wiring for 3-wire potentiometer throttle (“Type 2”).

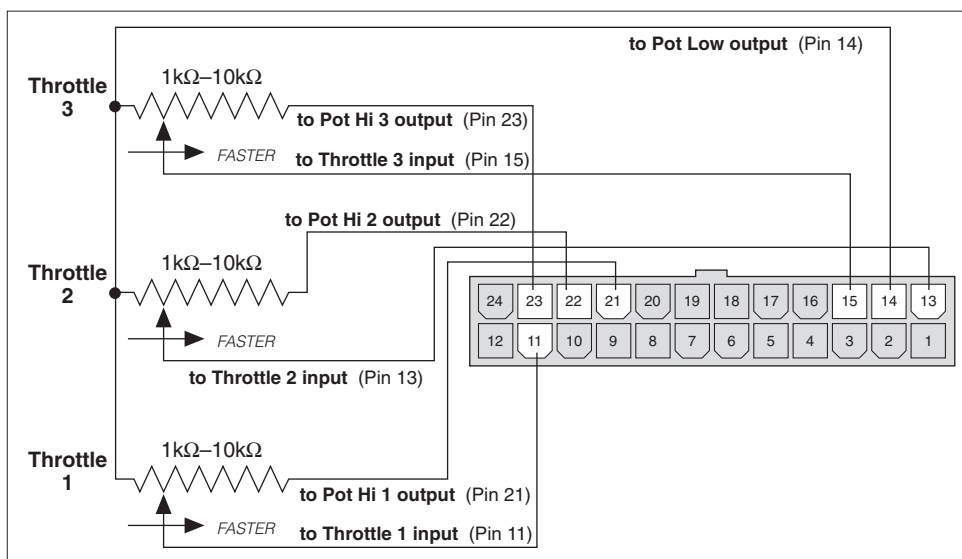

*Curtis ET-XXX Electronic Throttle*

The Curtis ET-XXX provides a 0–5V throttle input and also Lift/Lower inputs for the 1254 controller. Wiring for the ET-XXX is shown in Figure 9.

**Fig. 9** *Wiring for Curtis ET-XXX electronic throttle (“Type 2”).*

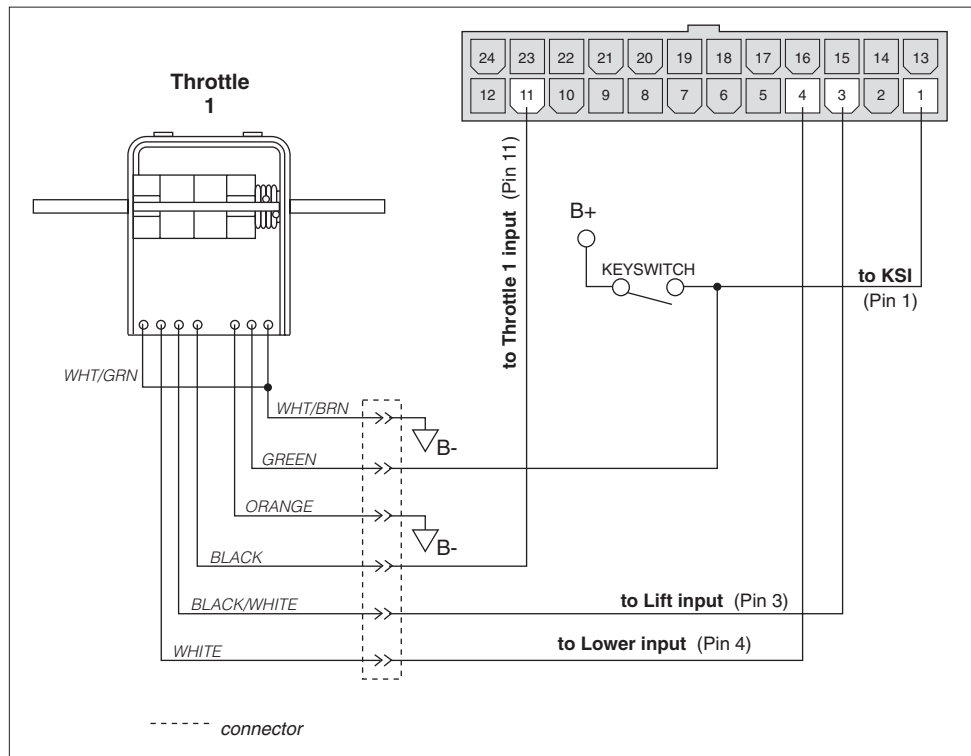

There is no fault detection built into the ET-XXX, and the controller will detect only open wiper faults. It is the responsibility of the OEM to provide any additional throttle fault detection necessary.

The ET-XXX can be integrated into a control head to provide wigwag-style throttle control. Alternatively, a complete control head assembly is available from Curtis. This control head assembly—the CH series—combines the ET-XXX throttle with a variety of standard control head switch functions.

**0–5k $\Omega$  Throttle (“Type 3”)**

The 0–5k $\Omega$  throttle (“Type 3” in the programming menu) is a 2-wire resistive throttle that connects between a pot wiper pin (Throttle 1, 2, or 3 input pin) and the Pot Low output pin, as shown in Figure 10. Zero speed corresponds to 0 $\Omega$  measured between the two pins and full speed corresponds to 5 k $\Omega$ . This throttle type is not appropriate for use in wigwag-style applications.

If the total resistance between a Throttle Input pin and Pot Low output pin is greater than 7.5 k $\Omega$ , the controller’s upper fault limit will be exceeded (see Table 1) and that throttle’s input value will be zeroed. This provides broken wire



**Fig. 10** Wiring for 0–5kΩ throttle (“Type 3”).

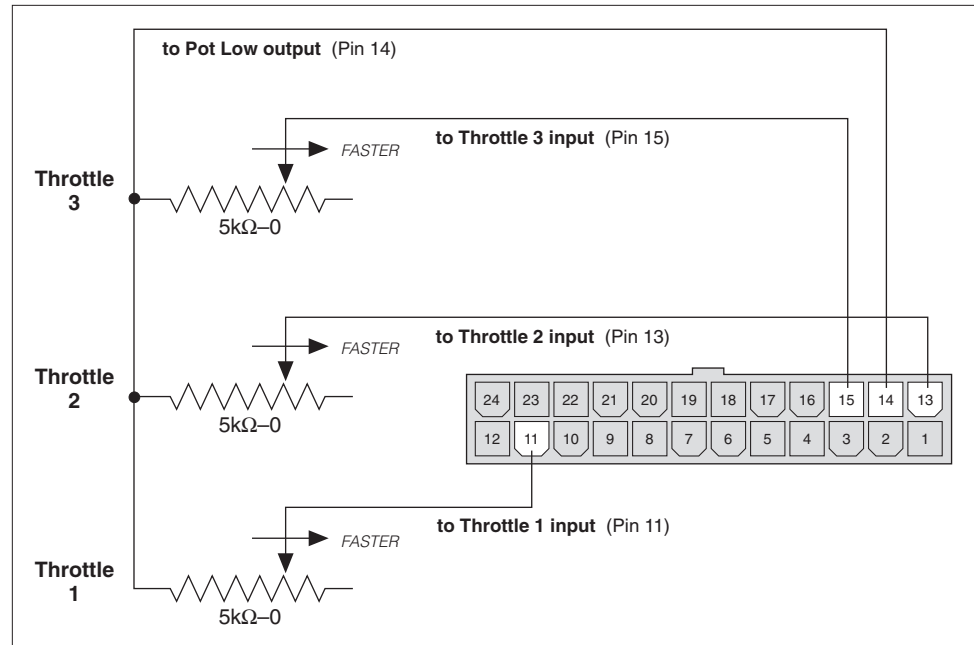

protection, and also serves as an indication that the potentiometer’s resistance has increased beyond the acceptable range and that the pot therefore needs to be replaced.

#### Wigwag-Style 0–5V Voltage Source and 3-Wire Pot Throttle (“Type 4”)

These throttles (“Type 4” in the programming menu) operate in true wigwag style. The neutral point will be with the wiper at 2.5 V (measured between the Throttle 1,2,3 pin and B-). For Throttle 1, the controller will provide increasing Lift speed as the wiper input value is increased, with maximum Lift speed reached at 4.5 V. The controller will provide increasing Lower speed as the wiper input value is decreased, with maximum Lower speed reached at 0.5 V. For Throttles 2 and 3, the controller will provide increased motor speed in either direction.

When a 3-wire pot is used, the controller provides full fault protection. Any potentiometer value between 1 kΩ and 10 kΩ is supported.

A 0–5V voltage source can also be used as the wiper input (see Figure 6). However, the minimum and maximum wiper voltage must not exceed the 0.5V and 4.5V fault limits. When a voltage throttle is used, it is the responsibility of the OEM to provide appropriate throttle fault detection.

With a Type 4 throttle, no signals to the controller’s Lift and Lower inputs are required. The action is determined by the Throttle 1 wiper input value. The interface to the controller is similar to that for Type 2 devices.

### CAN-Nodes Speed Control (“Type 5”)

The “Type 5” speed control option is designed for use with CAN-based control systems. No connections are required to the controller’s Throttle, Pot High, or Pot Low pins or to the Lift and Lower pins, because all communications are handled through the 6-pin CAN-Nodes interface connector. Details on how to combine a given throttle with the CAN-Nodes system are provided in the Curtis CAN Protocol Document. Fault detection for Type 5 throttles is handled by the CAN CRC (Cyclic Redundancy Check) function, which is part of each node in the CAN Bus architecture.

### WIRING: Fault Outputs

The 1254 controller has two fault output drivers, at Pin 5 and Pin 6, which can be used to provide diagnostic information either to a display panel on the vehicle or to a remote location. These outputs are rated at 10 mA maximum current at the nominal battery pack voltage. For information on programming these outputs, see Section 3: Programmable Parameters.

Wiring for the Fault 1 and Fault 2 outputs is shown in Figure 11.

**Fig. 11** *Wiring for fault outputs.*

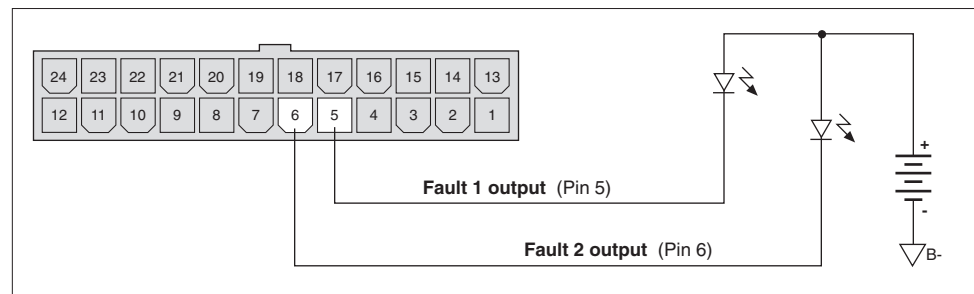

### WIRING: Hour Meter

The hour meter output (Pin 12) pulls to B+ to enable an hour meter whenever current is flowing in the pump motor. This allows accurate accumulation of motor operating hours. The output is current limited to 20 mA, and is compatible with Curtis 700 and 800 series hour meters. For wiring, consult the documentation supplied with the hour meter.

### WIRING: CAN Bus Interface

Refer to the Curtis CAN Protocol Document for information about the CAN Bus interface.

## **CONTACTOR, SWITCHES, and OTHER HARDWARE**

### Pump Contactor

A pump contactor should be used with the 1254 controller. Otherwise, the controller's fault detection will not be able to fully protect the controller and hydraulic system from damage in a fault condition. The pump contactor allows the controller and motor to be disconnected from the battery. This provides a significant safety feature, because it means the battery power can be removed from the hydraulic system if a controller or wiring fault results in battery power being applied to the motor inappropriately.

A single-pole, single-throw (SPST) contactor with silver-alloy contacts, such as an Albright SW180 or SW200 (available from Curtis), is recommended for use as the pump contactor.

The 1254 controller provides a low-side contactor coil driver (at Pin 17) for the pump contactor. The driver output is rated at 2 amps, is overcurrent protected at 3 amps, and is checked for open coil faults. A built-in coil suppression diode is connected between the pump contactor coil driver output and the keyswitch input. This protects the contactor coil driver from inductive voltage kickback spikes when the contactor is turned off.

For information on programming the various contactor-related parameters, see Section 3: Programmable Parameters.

### Keyswitch and Interlock Switch

The vehicle should have a master on/off switch to turn the system off when not in use. The keyswitch input provides logic power for the controller.

The interlock switch, which is typically implemented as a seatswitch or a hand/foot activated deadman switch, provides a safety interlock to ensure that an operator is present in order for the system to run.

The keyswitch and interlock switch provide current to drive the pump contactor coils and the valve solenoids as well as the controller's internal logic circuitry, and must be rated to carry these currents.

### Speed Select, Lift, and Lower Switches

These input switches can be any type of single-pole, single-throw (SPST) switch capable of switching the battery voltage at 25 mA.

### Reverse Polarity Protection Diode

For reverse polarity protection, a diode should be added to the control circuit. This diode will prohibit pump contactor operation and current flow if the battery pack is accidentally wired with the B+ and B- terminals reversed. It should be sized appropriately for the maximum contactor coil, valve solenoid, and fault diode currents required from the control circuit. The reverse polarity protection diode should be wired as shown in the standard wiring diagrams (Figures 3 and 4).

### Circuitry Protection Devices

To protect the control circuitry from accidental shorts, a low current fuse (appropriate for the maximum current draw) should be connected in series with the battery feed to the keyswitch. Additionally, a high current fuse should be wired in series with the pump contactor to protect the motor, controller, and batteries from accidental shorts in the power system. The appropriate fuse for each application should be selected with the help of a reputable fuse manufacturer or dealer. The standard wiring diagrams (Figures 3 and 4) show the recommended location for each fuse.

### Valves

The proportional valve and load holding valve on the Lift cylinder line should be large enough to provide adequate flow when open.

The load holding valve's solenoid coil should be rated at the nominal battery voltage of the system and must not exceed the 2 amp rating of its driver. There is no voltage requirement for the proportional valve solenoid coil; it should be capable of opening the valve completely using not less than half an amp of current and not more than 3 amps.

The 1254 controller provides a low-side load-holding valve solenoid driver at Pin 18; this driver output is rated at 2 amps, and is overcurrent protected at 3 amps. A low-side proportional valve solenoid driver is provided at Pin 19; this driver output is rated at 3 amps, is overcurrent protected, and is checked for open coil faults.

A built-in coil suppression diode is connected between the valve solenoid driver outputs and the keyswitch input. This protects the drivers from inductive voltage kickback spikes when they are turned off.

For information on programming the various valve-related parameters, see Section 3: Programmable Parameters.

# 3

## PROGRAMMABLE PARAMETERS

The 1254 controller has a number of parameters that can be programmed by means of a 1307 handheld programmer. These programmable parameters allow the hydraulic system's performance characteristics to be customized to fit the needs of individual applications or system operators.

Each controller is shipped with the parameter settings specified by the OEM. For each programmable parameter, the specification process includes designating whether it is to have User, OEM, or factory-only access rights. The OEM specifies which they will be able to adjust themselves, and which—if any—parameters the user (dealer, distributor, etc.) will be able to adjust. Curtis offers two versions of the 1307 programmer: the 1307M-1101 is the User programmer (which can adjust only those parameters with User access rights) and the 1307M-2101 is the OEM programmer (which can adjust all the parameters with User or OEM access rights).

The programmable parameters are described in the following order. They are listed in the text by the abbreviated names that appear in the programmer's Program Menu. Not all of these parameters are displayed on all controllers; the list for any given controller depends on its specifications.

---

### *Speed Select Parameters*

- Maximum Speed, SS1–SS6
- Minimum Speed
- Minimum Speed Disable
- Speed Select Acceleration Rate
- Speed Select Deceleration Rate

### *Throttle Parameters*

- Throttle Type
- Lift Maximum Speed, Throttle 1
- Lower Maximum Speed, Throttle 1
- Maximum Speed, Throttles 2–3
- Throttle Acceleration Rate
- Throttle Deceleration Rate
- Throttle Deadband
- Throttle Max
- Throttle Map

### *Final Speed Request Parameters*

- Multifunction
- Add Mode, SS1–SS6
- Add Mode, Throttles 1–3
- Final Add Mode

***Fault Parameters***

Throttle Fault, Throttles 1–3  
Lift Lockout  
Startup Lockout  
Fault Code

***Pump Contactor Driver Parameters***

Pump Contactor Control  
Pump Contactor Dropout Delay  
Sequencing Delay  
Pump Contactor Diagnostics

***Valve Parameters***

Proportional Valve Gain  
Valve Control  
Coil Check  
Proportional Valve Maximum Current  
Proportional Valve Minimum Current  
Proportional Valve Dither  
Proportional Valve Acceleration Rate  
Proportional Valve Deceleration Rate  
Load Hold Delay

***Other Parameters***

Current Limit  
Battery Voltage  
Current Ratio  
Precharge  
Load Compensation

***Field Control Parameters***—OPTIONAL  
(separately excited motor applications only)

Sepex Option  
Maximum Field Current Limit  
Minimum Field Current Limit  
Field Map Start  
Field Map

***CAN-Nodes Parameters***—OPTIONAL  
(CAN-Nodes control systems only)

Nodes Option  
Node Address

---

---

## ***Speed Select Parameters***

*The 1254 controller can accept inputs from up to six individual speed select switches (SS1–SS6). The controller adjusts the pump motor’s PWM output in response to these inputs, using algorithms prescribed by the programmed acceleration/deceleration rates to reach the designated speeds.*

*The first three speed select switches (SS1–SS3) can be integrated into a multifunction handle; see Multifunction parameter.*

*NOTE: The programmed Minimum Speed is in effect regardless of whether the speed request comes from a speed select switch or a throttle.*

### **SS1–SS6, SPEED**

The **maximum speed** parameter defines the maximum allowed armature PWM output of the pump motor. It can be set independently for up to six individual speed select switches (i.e., SS1 SPEED, SS2 SPEED, etc.). The maximum speed parameter is adjustable from 0% to 100% of the full output, in 1% increments.

### **MINIMUM SPEED**

The **minimum speed** parameter defines the minimum allowed armature PWM output of the pump motor, and is adjustable from 0 to 50% of the full output, in 1% increments. The minimum speed feature ensures that adequate pressure is maintained for the power steering system and for lubrication.

### **MIN SPD DISABL**

The **minimum speed disable** parameter allows the minimum speed parameter to be disabled. It can be programmed On (programmed minimum speed is disabled) or Off (programmed minimum speed is in effect).

### **SS ACCEL RATE**

The **speed select acceleration rate** parameter defines the time it takes for the controller to accelerate from 0% output to 100% output when a speed select switch is closed. The setting for this parameter affects all six speed selects. The speed select acceleration rate is adjustable from 0.1 to 3.0 seconds, in 0.1 second increments.

### **SS DECEL RATE**

The **speed select deceleration rate** parameter defines the time it takes for the controller to decelerate from 100% output to 0% output when a speed select switch is opened. The setting for this parameter affects all six speed selects. The speed select deceleration rate is adjustable from 0.1 to 3.0 seconds, in 0.1 second increments.

## Throttle Parameters

Most applications use throttles in order to provide variable speed control of various hydraulic operations (e.g., lift, reach, tilt, shift, rotate). Although it is possible to use only simple on/off speed select switches, throttles give the operator more flexibility and control over performance than is provided by the switches.

The 1254 controller can accept inputs from up to three throttles: Throttle 1 (Lift/Lower), Throttle 2, and Throttle 3. The Lift and Lower maximum speeds on Throttle 1 can be set independently.

### THROTTLE TYPE

The 1254 controller accepts a variety of throttle inputs, including 5k $\Omega$ –0 and 0–5k $\Omega$  two-wire rheostats, 3-wire pots, 0–5V throttles, Curtis ET-XXX electronic throttles, and CAN-Nodes based throttles.

The standard throttle input signal type options—Types “1” through “5” in the programming menu—are listed in Table 2. Wiring information and performance characteristics for each type are presented in Section 2.

The **throttle type** parameter applies to all the throttles in the system; therefore if more than one is used they should all be of the same type. If no throttles are used in the application, the throttle type parameter should be set to Type 2. Otherwise, the controller will register a throttle fault (unless all three Throttle Faults are programmed Off—see Fault parameters).

THROTTLE TYPE	DESCRIPTION
1	5k $\Omega$ –0, 2-wire rheostat
2	single-ended 3-wire potentiometer (1k $\Omega$ to 10k $\Omega$ range) or single-ended 0–5V input (from voltage throttle, Curtis ET-XXX electronic throttle, or current source)
3	0–5k $\Omega$ , 2-wire rheostat
4	wigwag 3-wire potentiometer (1k $\Omega$ to 10k $\Omega$ range) or wigwag 0–5V input (from voltage throttle)
5	CAN-Nodes throttle

### LIFT MAX SPEED

When the Lift switch is closed, the controller activates the load hold valve, thus enabling the Lift function; see Figure 12. The **Lift maximum speed** parameter defines the maximum allowed armature PWM output during the Lift operation. The Lift speed parameter is adjustable from 0% to 100% of full output, in 1% increments. If Lift speed is set at 80%, the maximum output will be 80% with Throttle 1 in the full on position. At three-quarters throttle, maximum output will be 60% (75% of 80%)—assuming a linear throttle map (see page 30).



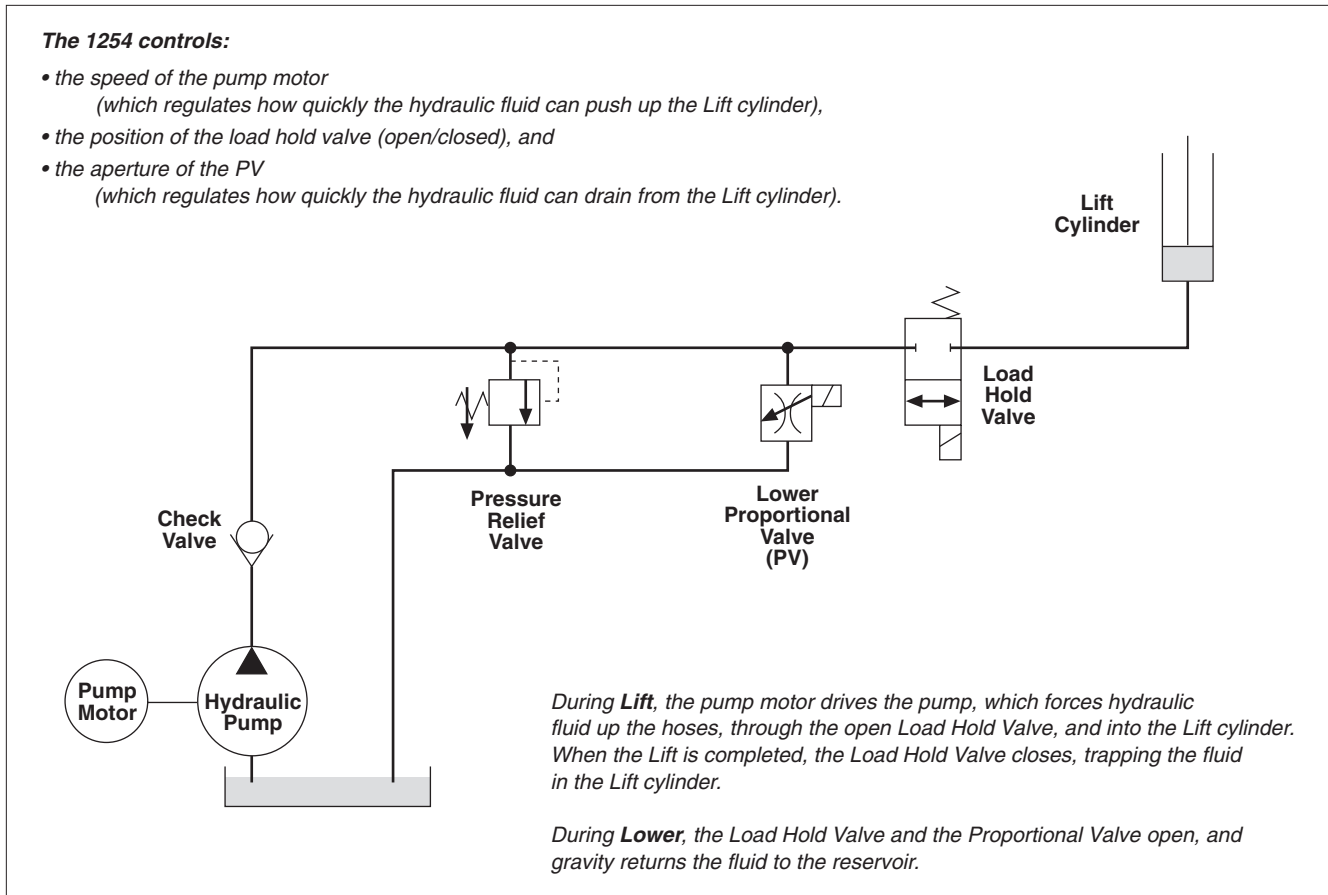

**Fig. 12** Lift/Lower hydraulic system diagram.

## LOWR MAX SPEED

When the Lower switch is closed, the controller activates the load hold valve and the proportional valve, thus enabling the Lower function; see Figure 12. The **Lower maximum speed** parameter defines the maximum allowed proportional valve current as a percentage of the PV maximum current. The Lower maximum speed parameter is adjustable from 0% to 100% of the PV's maximum current; for information on setting the PV max current, see valve parameter section.

NOTE: the Lower Max Speed and PV Max Current parameters are redundant. If you want the PV maximum current to be 1.5 amps, you could set the PV Max Current to 3 amps and the Lower Max Speed to 50%, or you could set the PV Max Current to 1.5 amps and the Lower Max Speed to 100%; either combination would give a PV maximum current of 1.5 amps.

## THR2–THR3 MAX SPEED

The **Thr2** and **Thr3 maximum speed** parameters define the maximum allowed armature PWM output in response to inputs from Throttle 2 and Throttle 3. These two maximum speed parameters are individually adjustable from 0% to 100% of the controller's full output, in 1% increments.

## THROTTLE ACCEL

The **throttle acceleration rate** parameter defines the time it takes for the controller to accelerate from 0% output to 100% output when full output is requested. The setting for this parameter affects all the throttles in the hydraulic system: Throttle 1 (Lift/Lower), Throttle 2, and Throttle 3. The throttle accel rate is adjustable from 0.1 to 3.0 seconds, in 0.1 second increments.

## THROTTLE DECEL

The **throttle deceleration rate** parameter defines the time it takes for the controller to decelerate from 100% output to 0% output when the requested speed changes from full output to none. The setting for this parameter affects all the throttles in the hydraulic system: Throttle 1 (Lift/Lower), Throttle 2, and Throttle 3. The throttle decel rate is adjustable from 0.1 to 3.0 seconds, in 0.1 second increments.

## DEADBAND

The **throttle deadband** parameter defines the pot wiper voltage range the controller interprets as neutral. Increasing the throttle deadband setting increases

**Fig. 13** Effect of adjusting the throttle deadband parameter (throttle types 1 and 2).

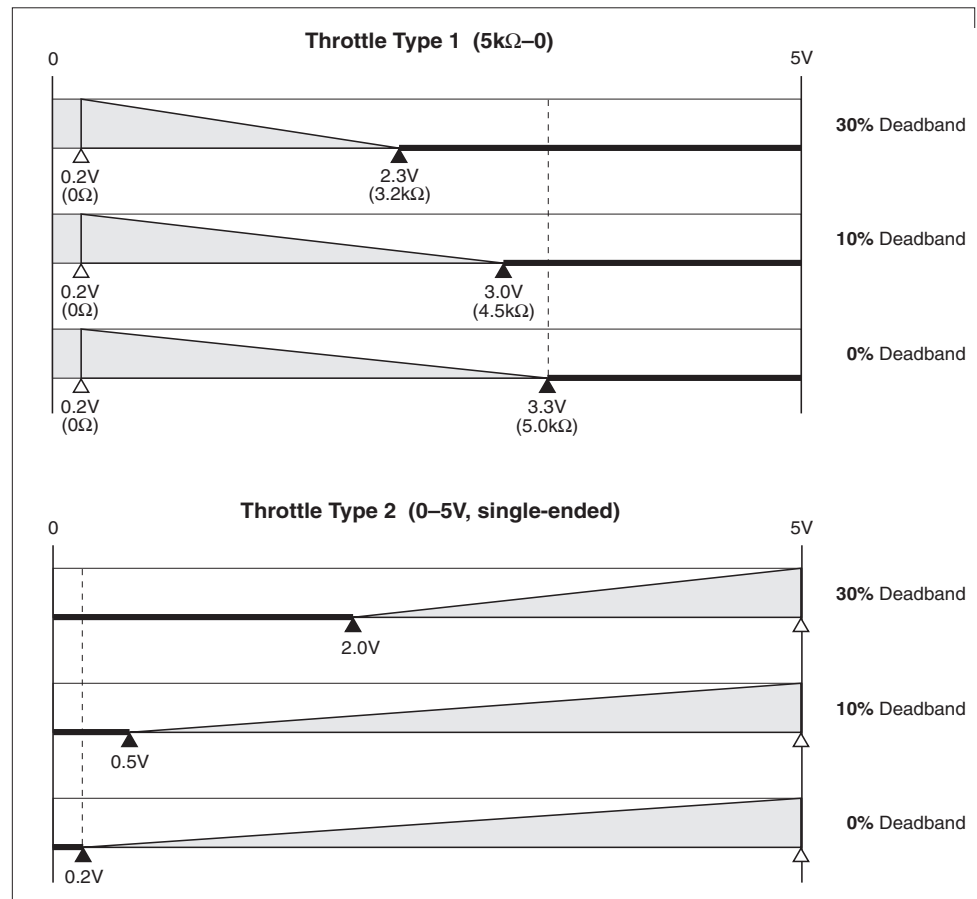

**Fig. 13, cont'd** *Effect of adjusting the throttle deadband parameter (throttle types 3 and 4).*

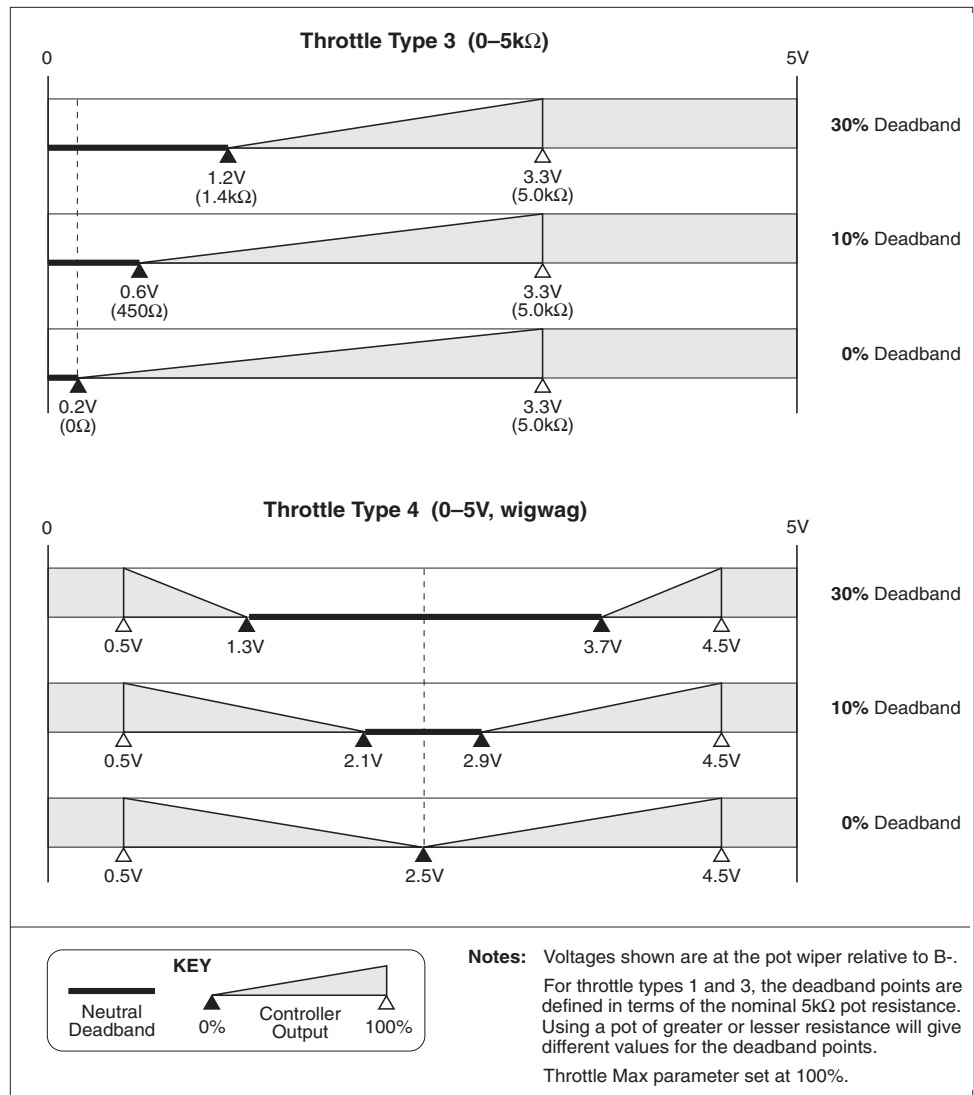

the neutral range. This parameter is especially useful with throttle assemblies that do not reliably return to a well-defined neutral point, because it allows the deadband to be defined wide enough to ensure that the controller goes into neutral when the throttle mechanism is released.

Examples of deadband settings (30%, 10%, 0%) are shown in Figure 13 for throttle types 1 through 4, using a nominal 5kΩ–0 potentiometer (where applicable). For throttle type 5, see the Curtis CAN Protocol Document.

The programmer displays the throttle deadband parameter as a percentage of the nominal wiper voltage range and is adjustable from 0% to 30%, in 2% increments. The default deadband setting is 10%. The nominal wiper voltage range depends on the throttle type selected. See Table 1 (page 12) for the characteristics of your selected throttle type.

The deadband parameter applies to all throttles in the hydraulic system.

### THROTTLE MAX

The **throttle max** parameter sets the throttle wiper voltage required to produce 100% controller output. Decreasing the throttle max setting reduces the wiper voltage and therefore the full stroke necessary to produce full controller output. This feature allows reduced-range throttle assemblies to be accommodated.

Examples are shown in Figure 14 for throttle types 1 through 4, using a nominal 5kΩ potentiometer (where applicable); for throttle type 5, see the Curtis CAN Protocol Document. These examples illustrate the effect of three different max output settings (100%, 90%, 60%) on the full-stroke wiper voltage required to attain 100% controller output.

The programmer displays throttle max as a percentage of the throttle’s active voltage range. The nominal voltage range depends on the throttle type selected. See Table 1 (page 12) for the characteristics of your selected throttle type. The throttle max parameter can be adjusted from 100% to 60%, in 2% increments.

Throttle max applies to all the throttles in the hydraulic system.

**Fig. 14** Effect of adjusting the throttle max parameter (throttle types 1 and 2).

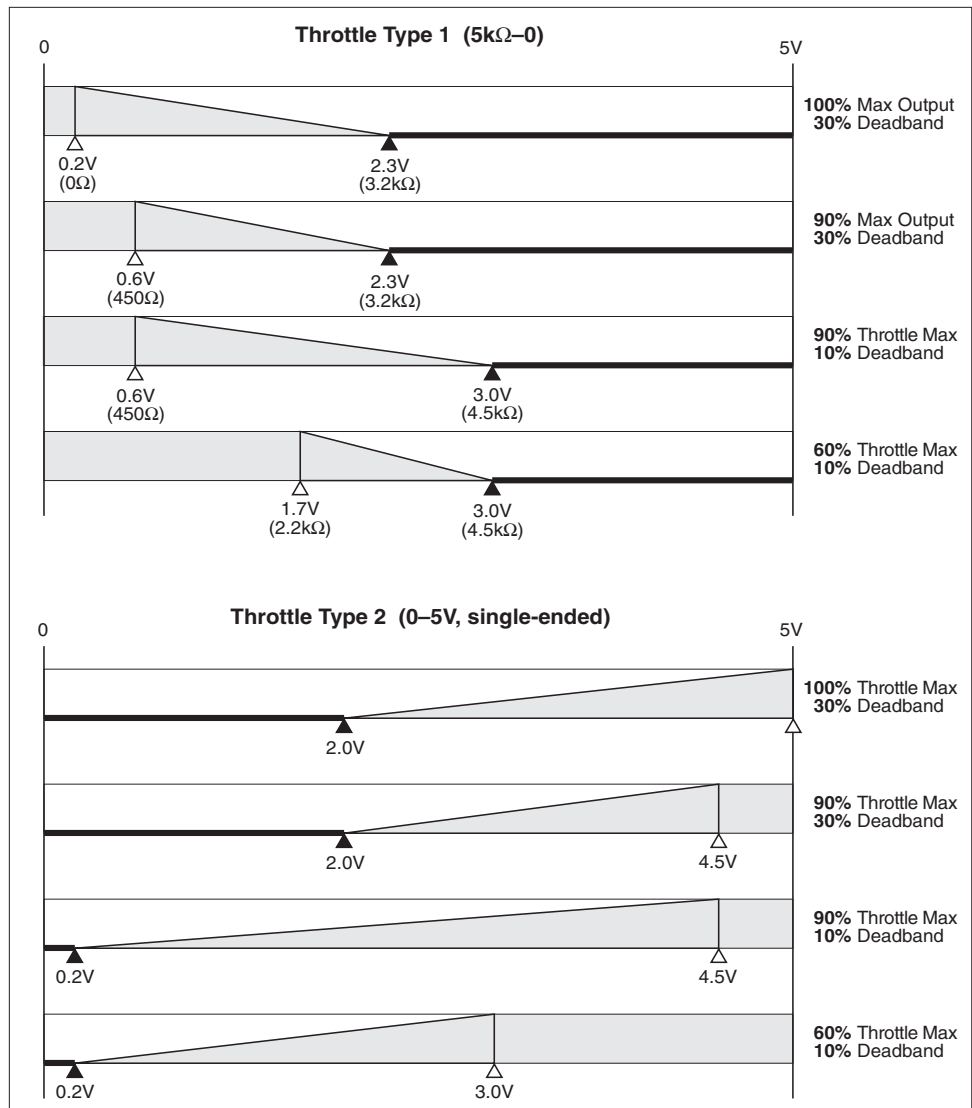

**Fig. 14, cont'd**

*Effect of adjusting the throttle max parameter (throttle types 3 and 4).*

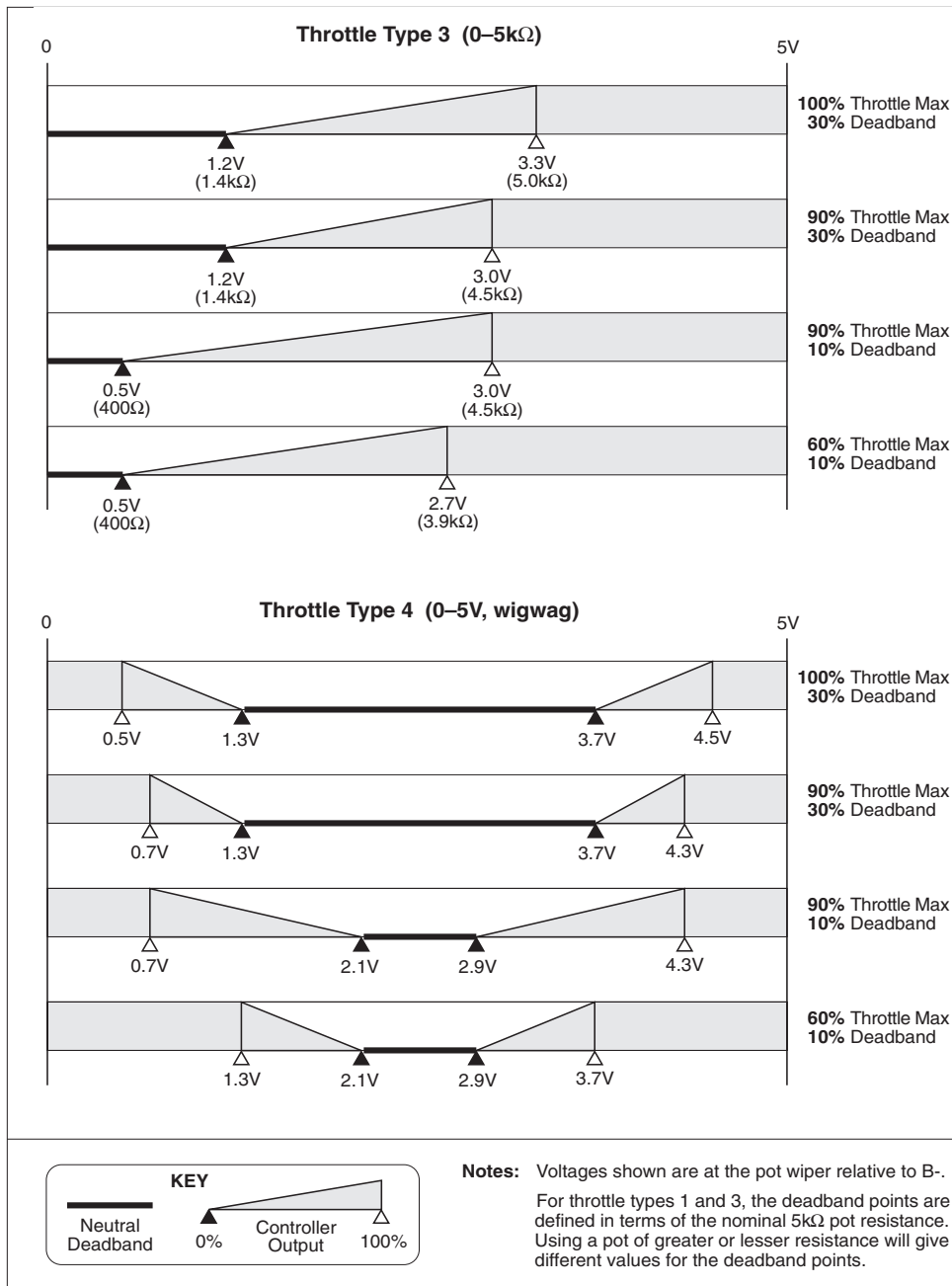

## THROTTLE MAP

The **throttle map** parameter modifies the response to a throttle input. This parameter determines the controller output for a given amount of applied throttle. Setting the throttle map parameter at 50% provides a linear output response to throttle position. Values below 50% reduce the controller output at low throttle requests, providing enhanced slow speed control. Values above 50% give the function a faster, jumpier feel at low throttle requests.

The throttle map can be programmed in 5% increments between 20% and 80%. The number refers to the controller output at half throttle, as a percentage of the throttle's full active range. The throttle's active range is the voltage or resistance between the 0% output point (throttle deadband) and the 100% output point (throttle max). For example, if maximum speed is set at 100%, a throttle map setting of 50% will give 50% output at half throttle. The 50% setting corresponds to a linear response. Six throttle map profiles (20, 30, 40, 50, 60, and 80%) are shown as examples in Figure 15, with the maximum speed set at 100%.

**Fig. 15** Throttle maps for controller with maximum speed set at 100%.

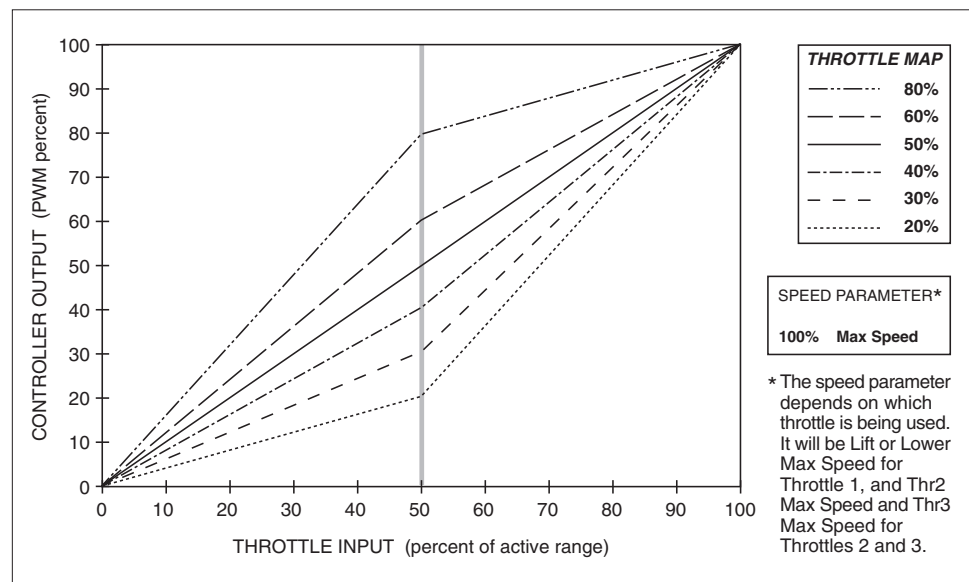

Lowering the max speed limits the controller's output range. Throttle map profiles with the max speed reduced from 100% to 80% are shown in Figure 16. The throttle map is always a percentage of the controller's output range. So, in these examples, the throttle map is a percentage of the 0–80% output range; a 40% throttle map setting will give 32% output at half throttle (40% of 80% = 32%). Controller output will begin to increase as soon as the throttle is rotated out of its normal neutral range (deadband). Controller output will continue to increase, following the curve defined by the throttle map setting, as

**Fig. 16** Throttle maps for controller with maximum speed set at 80%.

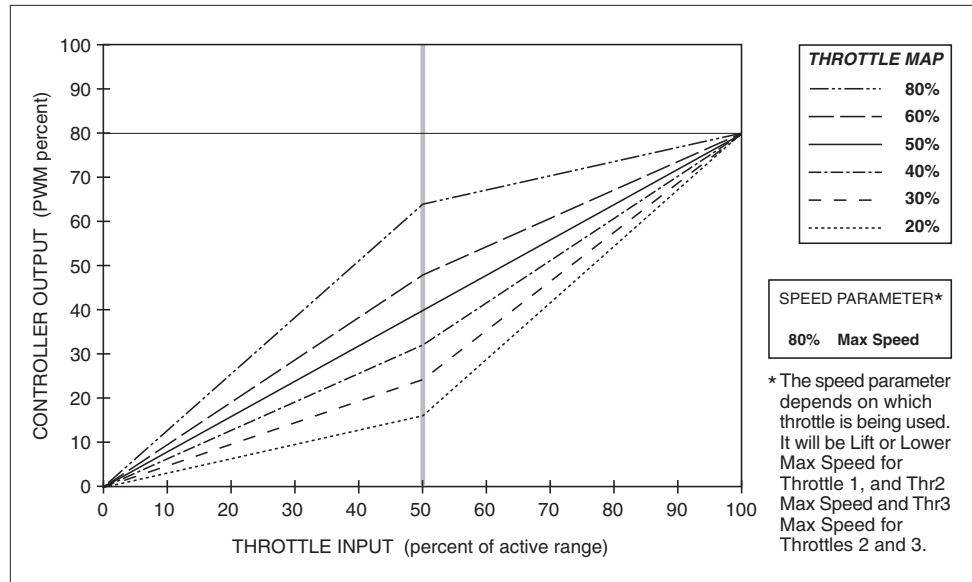

the throttle input increases and will reach maximum output when the throttle input enters the upper deadband (crosses the throttle max threshold).

The Throttle Map operates within the window established by the Max Speed, Throttle Deadband, and Throttle Max parameters, as shown below in Figure 17. Max Speed defines the controller’s output range, while Throttle Deadband and Throttle Max define the throttle’s active range. These three parameters, together with the Throttle Map, determine the controller’s output response to throttle demand.

The throttle map parameter applies to all the throttles in the hydraulic system.

**Fig. 17** Influence of various parameters on controller output response to throttle demand.

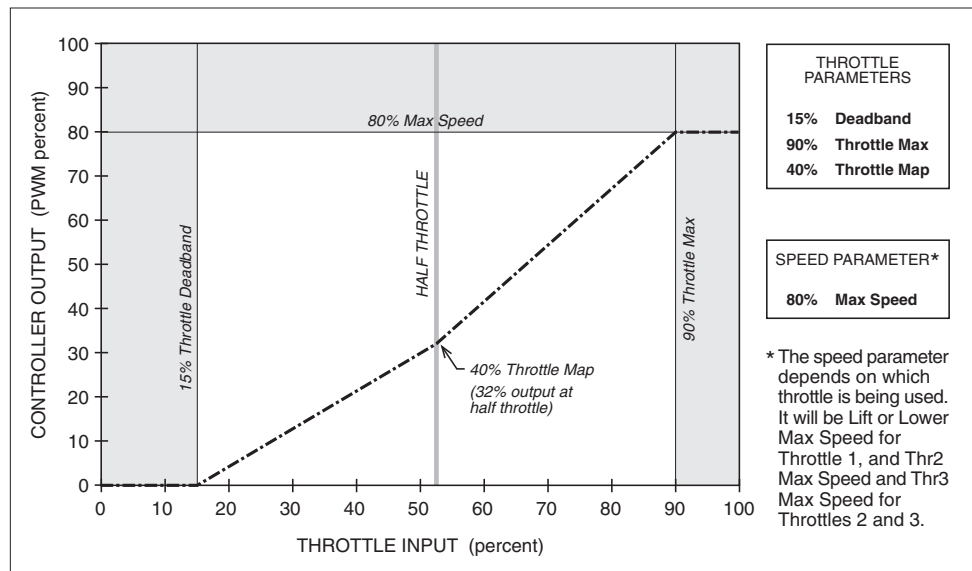

### ***Final Speed Request Parameters***

*The final speed request parameters define how the controller will handle multiple requests—from more than one speed select switch, from more than one throttle, or from a combination of speed select switches and throttles. It is this single final calculated speed that is demanded of the pump motor.*

*When multiple requests are received, the controller can add them (“add mode”) or accept only the first request (“first-on mode”), depending on how the following parameters are set.*

### **MULTIFUNCTION**

The **multifunction** parameter enables Lift and Lower to be combined with up to three additional operations (controlled by speed select switches SS1–SS3) in a single multifunction control handle, governed by Throttle 1.

When multifunction is programmed On, Throttle 1 scales the maximum speeds of all the functions included in the handle. Regardless of whether they were individually programmed with Add Mode on or off, all the functions within the handle are in First-On Mode when multifunction is programmed On.

When multifunction is Off, Throttle 1 no longer scales the SS1–SS3 operations, and their individually-set Add Mode parameters are in effect.

### **SS1–SS6, ADD MODE**

The **speed select Add Mode** parameter enables Add Mode for speed select switches SS1–SS6. Add Mode can be enabled or disabled (programmed On or Off) individually for each of the six switches.

When SS Add Mode is Off, the controller responds to the first request it receives and ignores—or “locks out”—any subsequent requests; this is called “First-On Mode.” If SS3 is the first speed select switch to be closed, the controller accelerates to the programmed SS3 maximum output. If SS2 is then closed, the controller output (and the pump speed) remain the same and the SS3 operation is slowed because it must share the available hydraulic pressure with the SS2 operation. If two or more speed select switches are closed simultaneously, the controller responds to the lowest-numbered switch (i.e., SS2 takes precedence over SS3, etc.).

When SS Add Mode is On, the controller increases the pump speed in order to maintain the level of work requested by each speed select switch input; this is called “Add Mode,” because the individual requests are added together. If SS3 is the first speed select switch to be closed, the controller accelerates to the programmed SS3 maximum output. If SS2 is then closed, the controller output (and the pump speed) increase so that each operation is performed at the same level of effort as if it were operating alone. The controller sends the pump the required amount of power (up to 100% of maximum output) to provide enough hydraulic pressure to perform all the requested operations at their individually-specified maximum speeds.



Final SS request. The final SS request is the first First-On request, if Add Mode is programmed Off for all six speed select switches. It is the sum of the requests if Add Mode is programmed On for all six switches. Because Add Mode can be programmed individually for each SS switch, some may be set On and some Off. When this is the case, the first “First-On” SS input the controller receives locks out any other “First-On” SS inputs that may follow; this single First-On input is added to the sum of all the Add Mode SS inputs that have been received, and this sum becomes the final SS request.

### THRTL ADD MODE

The **throttle Add Mode** parameter enables Add Mode for throttles 1–3. Add Mode is either enabled or disabled (programmed On or Off) for all three throttles.

When throttle Add Mode is Off, the controller responds to the first throttle request it receives and ignores any subsequent requests; this is called “First-On Mode.” If Throttle 3 is the first throttle input it receives, the controller responds according to the parameters established for Throttle 3. If Throttle 2 is then also actuated, the controller output (and the pump speed) remain the same and the operation controlled by Throttle 3 is slowed because it must share the available hydraulic pressure with the operation controlled by Throttle 2.

When throttle Add Mode is On, the controller increases the pump speed in order to maintain the level of work requested by each throttle. The controller sums the individual throttle requests and sends the pump the required amount of power (up to 100% of maximum output) to provide enough hydraulic pressure to perform all the requested operations at their individually-requested speeds.

Final throttle request. The final throttle request is the first First-On throttle request, if throttle Add Mode is programmed Off, and it is the sum of the individual throttle requests if throttle Add Mode is programmed On.

### FINAL ADD MODE

Typically, some operations are controlled by speed select switches and others by throttles. The **Final Add Mode** parameter determines whether the controller will respond to the first request it receives (either the final SS request or the final throttle request) or whether it will add them. If Final Add Mode is programmed Off, the pump speed will be defined by the first request it receives (final SS or final throttle). If Final Add Mode is programmed On, the controller will sum the two requests (up to 100% output). The “final” speed request that is sent to the motor is, of course, temporary—the final request is constantly recalculated in response to changes in the inputs.

See the diagrams in Appendix D for more speed conditioning detail.

## *Fault Parameters*

### **THRTL 1-2-3 FAULT**

The 1254 controller is designed to issue a fault if there is a problem with a throttle or its wiring. The **throttle fault** parameter enables this feature individually for each throttle. For each throttle that is installed in the system, the corresponding throttle fault should be programmed On. The throttle fault for any unused throttle should be programmed Off, to prevent a throttle fault from being issued on a nonexistent throttle.

The throttle fault parameter affects diagnostics only. Regardless of how the throttle fault parameter is set, if there is no connection to a given throttle that throttle input is assumed to be zero.

### **LIFT LOCKOUT**

The Lift lockout feature is designed to prevent Lift operation during undervoltage conditions. The **Lift lockout** parameter can be programmed On or Off. When programmed On, if the interlock input goes low during a Lift operation, the Lift in progress will be completed but further Lift requests will be ignored as long as the interlock input stays low. If programmed Off, the Lift will continue to operate, just as if the interlock input were high. Lift lockout is delayed for the time specified by the sequencing delay parameter (see page 37).

NOTE: This feature is available only when the contactor control parameter is set to “2”; i.e., with the contactor pulled in with KSI—see Table 4, page 36.

### **STARTUP LOCKOUT**

The startup lockout feature prevents the pump motor from running if any of the throttle inputs (Throttle 1-2-3) is requesting more than 25% output or if any of the speed select inputs (SS1–SS6) is high when the controller is turned on. The **startup lockout** parameter is used to set the type of lockout. Two types of lockout are available: lockout on KSI input alone or lockout on KSI plus interlock inputs. Startup lockout can also be disabled. Startup lockout is delayed for the time specified by the sequencing delay parameter (see page 37).

#### No Startup Lockout (Type 0)

Startup lockout function is disabled.

#### KSI-type Startup Lockout (Type 1)

To start the pump motor, the controller must receive a KSI input before receiving a speed select input or a throttle input >25%. Controller operation will be disabled immediately if an inappropriate speed request is active at the time KSI is enabled, and a sequence error fault will be declared. If the inappropriate speed request is received before the interlock switch is closed but after the KSI input has been enabled, the motor will accelerate to the requested speed as soon

as the interlock switch is closed. Normal operation is regained by reducing any throttle requests to less than 25% and opening any speed select switches that were already closed.

### Interlock-type Startup Lockout (Type 2)

To start the pump motor, the controller must receive an interlock switch input in addition to a KSI input before receiving a speed select input or a throttle input >25%. Controller operation will be disabled immediately if an inappropriate speed request is active at the time the interlock switch is closed, and a sequence error fault will be declared. Normal operation is regained by reducing any throttle requests to less than 25% and opening any speed select switches that were already closed.

## FAULT CODE

The 1254 controller's fault code drivers allow faults to be displayed in either of two different formats: Fault Code format or Fault Category format. With the **fault code** parameter specified "On," the fault information will be in Fault Code format. With the fault code parameter specified "Off," the fault information will be in Fault Category format.

In Fault Code format, the two fault lines operate independently. When a fault is present, the Fault 1 driver (Pin 5) provides a pulsed signal equivalent to the fault code flashed by the controller's built-in Status LED. This signal can be used to drive an LED located on the display panel to provide the fault code information to an operator, or to any remote panel. The Fault 2 driver (Pin 6) pulls low (to B-) and remains on until the fault is cleared; it can also be used to drive a remote LED. When no faults are present, these outputs will both be open (off).

In Fault Category format, the two fault lines together define one of four fault categories. Table 3 describes the four fault categories and shows the state of the two outputs for each category.

FAULT CATEGORY	FAULT 1 OUTPUT (Pin 5)	FAULT 2 OUTPUT (Pin 6)	POSSIBLE EXISTING FAULTS
0	HIGH	HIGH	(no faults present)
1	<b>LOW</b>	HIGH	HW Failsafe; M-, Current Sensor, or Motor Fault; PV Solenoid Coil Open; Throttle 1-2-3 Fault; Pump Contactor or Contactor Driver Fault; Precharge Fault
2	HIGH	<b>LOW</b>	Low Battery Voltage; Overvoltage; Thermal Cutback
3	<b>LOW</b>	<b>LOW</b>	Lift Lockout; Sequence Error (Startup Lockout)

## Pump Contactor Driver Parameters

### CONTACT CNTRL

The **pump contactor control** parameter allows the OEM to define a dual switch requirement to operate the pump motor. When this parameter is set to “1,” there are no preconditions for closing the pump contactor. When set to “2,” KSI input is required for the pump contactor to be engaged. When set to “3,” both the KSI input (Pin 1) and the interlock input (Pin 2) must be pulled high (to B+) before the controller will engage the pump contactor. The pump contactor will open after the interlock switch is opened and the sequencing and pump contactor open delays expire. The three contactor control types are summarized in Table 4.

NOTE: If the pump contactor control parameter is set to “1,” EEC fault detection requirements will not be met—because the M- test is disabled.

TYPE	DEFINITION	INTERLOCK SWITCH FUNCTION	ENABLED FEATURES	DISABLED FEATURES
1	None; no control over contactor.	Enables and disables the pump motor. Interlock switch On means contactor is closed.	n/a	<ul style="list-style-type: none"> <li>• contactor diagnostics,</li> <li>• Lift lockout,</li> <li>• M- test,</li> <li>• precharge.</li> </ul>
2	Contactor is pulled in with KSI switch.	Interlock input used as BDI input only. Pump motor will run independent of interlock switch input unless Start Lockout parameter is programmed On.	<ul style="list-style-type: none"> <li>• contactor diagnostics,</li> <li>• Lift lockout,</li> <li>• M- test,</li> <li>• precharge.</li> </ul>	n/a
3	Contactor is pulled in with interlock switch.	Enables and disables the pump motor.	<ul style="list-style-type: none"> <li>• contactor diagnostics,</li> <li>• M- test,</li> <li>• precharge.</li> </ul>	<ul style="list-style-type: none"> <li>• Lift lockout.</li> </ul>

### CONT DELAY

The **pump contactor dropout delay** parameter is applicable only if the pump contactor control parameter has been set to “3.” The dropout delay can then be set to allow the pump contactor to remain closed for a period of time after the interlock switch is opened. If the delay parameter is programmed On, there will be a 40-second delay before the contactor opens after the interlock signal goes low; if programmed Off, there will be no delay. The delay is useful for preventing unnecessary cycling of the contactor and for maintaining power to auxiliary functions, such as a steering pump motor, that may be used for a short time after the operator has gotten up from the seat.

## SEQUENCING DLY

The **sequencing delay** feature allows the interlock switch to be cycled within a set time (the sequencing delay), in order to prevent inadvertent activation of startup lockout or Lift lockout. The sequencing delay parameter can be set from 0 to 3 seconds, in increments of 0.1 second, with 0 corresponding to no delay.

## CONT DIAG

The **pump contactor diagnostics** parameter, when set to On, performs ongoing checks to ensure that the pump contactor has closed properly each time it is commanded to so, and that it has not welded closed. These checks are *not* performed if the pump contactor diagnostics parameter is set to Off or if the pump contactor control parameter (see Table 4) is set to Type 1.

### Valve Parameters

*The 1254 controls the operation of the load-hold valve and the proportional (PV) valve. By so doing, it controls the hydraulic path for Lift and Lower operations.*

## PV GAIN

The **PV gain** parameter is used to calibrate the current sensor in the proportional valve. The 1254 comes with a default PV gain parameter setting (70–100) that is calibrated for most solenoids. However, because of the variety of PV solenoids, it is important to verify that the PV current sensor is calibrated for the specific solenoid that is being used.

To verify that the PV current sensor is calibrated correctly, and to recalibrate it if necessary, follow this procedure:

- Step 1.* Connect an ammeter in series with the PV solenoid as shown, to measure the PV solenoid current.

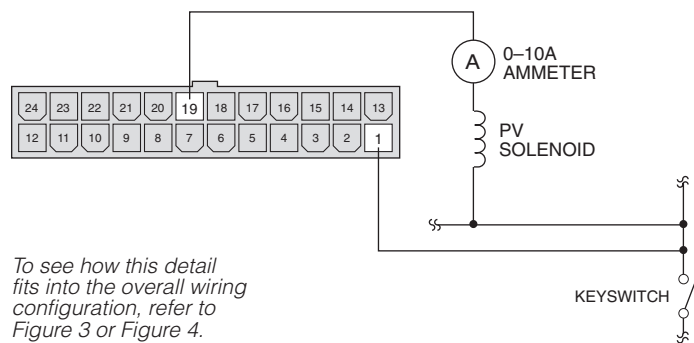

- Step 2.* Turn the keyswitch on. Using the 1307 programmer, set the valve control parameters as follows. Note that the

setting for the PV max current parameter is whatever value you choose, within the given range.

VALVE CNTRL	on
COIL CHECK	on
PV MAX CURR	— (0.0 – 3.0 amps)
PV MIN CURR	0.0 amps
PV DITHER	0 %
PV ACCEL	0.7 sec
PV DECEL	0.7 sec
LOAD HOLD DLY	1 sec
LOWR MAX SPEED	100 %

- Step 3.* Turn Interlock switch on.
- Step 4.* Turn Lower switch on.
- Step 5.* Set Throttle 1 to 100%.
- Step 6.* Measure PV current, using the ammeter. If it is within 10% of your set PV max current, the controller is properly calibrated. If the measured PV current is not within 10% of your set PV max current, proceed with Steps 7 and 8.
- Step 7.* Observe the PV PWM in the programmer's Test Menu.
- Step 8a.* *If PV PWM is less than 95%*, go to the Program Menu and increase the PV Gain parameter until the measured current is within 10% of your set PV max current.
- Step 8b.* *If PV PWM is greater than 95%*, go to the Program Menu and decrease the PV Gain parameter until the measured current is within 10% of your set PV max current. If the measured current is still too low with the PV Gain parameter decreased all the way to 1, that is the maximum PV current that can be obtained at that voltage with that particular solenoid.

The PV gain parameter is adjustable from 1 to 255.

## VALVE CNTRL

The **valve control** parameter, when programmed On, enables Lift and Lower by energizing the load-hold valve and the proportional (PV) valve when Lift or Lower is requested; see Figure 12, page 25. If the valve control parameter is programmed Off, the lift and lower switches—and Throttle 1 (Lift/Lower)—are ignored. However, if Throttle 1 has been integrated into a multifunction control handle (see page 32), it can still be used to scale SS1, SS2, and SS3.

**LOWR MAX SPEED** (see *Throttle parameters*)

Because it is a function of Throttle 1, the **Lower maximum speed** parameter is grouped with the throttle parameters (see page 25) even though it affects the allowed PV current.

**COIL CHECK**

The **coil check** parameter defines whether the controller performs missing coil checks on the PV solenoid coil. When this parameter is set to On, the controller senses the current at the PV driver output (Pin 19) to confirm that the coil is properly connected. If the criteria for this test are not met, the controller will inhibit operation and issue a PV coil open fault. This test is not performed if the coil check parameter is set to “Off.” NOTE: The coil check parameter is applicable only if the valve control parameter has been set to On.

**PV MAX CURR**

The **PV maximum current** parameter sets the maximum current the controller will provide to the proportional valve. The PV maximum current is programmable from 0 to 3 amps, in 0.1 amp increments. This parameter is redundant with the Lower maximum speed parameter; see page 25.

**PV MIN CURR**

The **PV minimum current** parameter sets the minimum current of the proportional valve. Some valves need a non-zero closed current to keep them from seating and sticking in the closed position. The PV minimum current is programmable from 0 to 1 amps, in 0.1 amp increments.

**PV DITHER**

The proportional valve dither feature provides a small constantly changing current in the coil to produce a small back-and-forth motion of the valve. This keeps the valve lubricated and allows low-friction, precise movement. The **PV dither** parameter specifies the amount of dither as a percentage of PWM, and is applied in a continuous 200 Hz cycle of none–add%–none–subtract%. The PV dither is programmable from 0 to 25%, in 1% increments.

**PV ACCEL**

The **PV current acceleration rate** parameter specifies how long it will take the proportional valve to go from fully closed to fully open. The PV current accel rate is programmable from 0.1 to 3.0 seconds, in 0.1 second increments.

## PV DECEL

The **PV current deceleration rate** parameter specifies how long it will take the proportional valve to go from fully open to fully closed. The PV current decel rate is programmable from 0.1 to 3.0 seconds, in 0.1 second intervals.

## LOAD HOLD DLY

The **load hold delay** parameter specifies how long the load-hold valve is kept open at the end of a Lift or Lower action. The delay time is programmable from 0 to 6 seconds, in 1 second increments. It is recommended that the load hold delay time be set > PV current decel time (to allow the proportional valve to close all the way at the completion of a Lower action) and > throttle decel time (to allow the pump speed to reach zero at the completion of a Lift action). The load hold valve is either open or shut, which means that it closes abruptly. To prevent jitter it is important that the load hold delay time be set long enough so that the load hold valve will not close until the hydraulic fluid is no longer flowing.

### *Other Parameters*

## CURRENT LIMIT

The **current limit** parameter defines the maximum armature current limit. The current limit is adjustable from 100 amps to the controller's full rated current (up to 700 amps), in 10 amp increments. The full rated current depends on the controller model.

## VOLTAGE

The **battery voltage** parameter sets the overvoltage and undervoltage protection thresholds for the controller—see Table E-1 at the back of the manual for these threshold values. The battery voltage parameter can be programmed from 2 to 7, and should always be programmed to the system's nominal battery pack voltage. This will ensure proper operation of all related electronics whenever the pump motor is operated.

SETTING	NOMINAL BATTERY PACK VOLTAGE
2	24V
3	36V
4	48V
5	60V
6	72V
7	84V



## CURRENT RATIO

The **current ratio** parameter defines how much of the programmed current (as set by the current limit parameter) will be available to the pump motor at reduced speed requests. This will determine the maximum torque the motor can provide when it is operating at less than full speed. The current ratio parameter can be set to 1, 2, 3, or 4. These settings represent a multiplication factor applied to the current that would otherwise be available.

SETTING	MULTIPLICATION FACTOR
1	1×
2	2×
3	4×
4	8×

For example, if 15% throttle is requested with the current ratio set at “1,” 15% of the battery voltage and 15% of the programmed current is allowed to flow in the motor (assuming a 50% throttle map setting). If the current ratio is set at “2” under these same conditions, 30% of the current is available; the motor speed remains the same, but the torque is doubled. Similarly, the motor speed stays the same with the current ratio set at “3,” but 60% (4×15% throttle) of the current is available. The controller never allows more than the programmed drive current to flow in the motor. If the current ratio is set at “3” with 40% throttle requested, the controller allows only 100% of the programmed current and not 160%.

Because the current ratio parameter affects how much torque the motor can provide, high current ratio settings will result in improved operation with heavy loads at low speed requests, but may cause harsh startups.

## PRECHARGE

The **precharge** parameter enables or disables the precharge function. When this parameter is set to “On,” the precharge function does not close the pump contactor until the internal power capacitor bank charges to within 13% of the battery voltage. Charging is accomplished internally and an external precharge resistor is not required. If the capacitor voltage does not reach this threshold, a precharge fault is issued and the pump contactor is never closed. Precharge reduces inrush current stresses on the capacitor bank and contactor and provides protection against allowing full battery power to be engaged if there is a short in the output section. Setting the parameter to “Off” disables the precharge function.

NOTE: Precharge is not performed, even if the precharge parameter is programmed On, if the contactor control parameter is set to Type 1 (none); see Table 4, page 36.

## LOAD COMP

The **load compensation** parameter actively adjusts the applied motor voltage as a function of motor load current. This results in more constant speeds over variations in load. Higher load compensation values will cause the controller to be more aggressive in attempting to maintain operation speed. However, too much load compensation can result in jerky starts and speed oscillation (“hunting”) when the load is light.

The load compensation parameter is adjustable from 0 to 25%.

### *Field Control Parameters*

*The 1254 controller is available in models designed for use with separately excited motors. These models provide a dedicated bus bar for the motor’s field winding; wiring for these applications is shown in Figure 4 (page 10). When a separately excited motor is used, its field can be controlled through the four programmable field parameters.*

## SEPEX

The **sepex option** parameter is used to enable the 1254 controller to drive a separately excited motor with a maximum field current rating of 40 amps. The sepex parameter can be programmed On or Off. When programmed On, the separately excited motor option and the field open fault are enabled. The field open fault will detect an open field winding if the field PWM reaches 97% while the measured field current is less than 2 amps.

## MAX FIELD

The **maximum field current limit** parameter defines the maximum allowed current in the motor’s field winding. The Max Field parameter is adjustable from 2 to 40 amps, in 0.5 amp increments.

## MIN FIELD

The **minimum field current limit** parameter defines the minimum allowed current in the motor’s field winding. The Min Field parameter is adjustable from 0 to 20 amps, in 0.5 amp increments.

## FLD MAP START

The **field map start** parameter defines the armature current at which the field map starts to increase from the Min Field value. This parameter is adjustable from 0 to 200 amps, in 5 amp increments.

## FIELD MAP

The **field map** parameter defines how much field current is applied for a given armature current. The Field Map parameter is set as a percentage of the field current between the Min Field and Max Field values. It is adjustable from 20% to 80%, in 5% increments.

As shown in Figure 18, the Field Map parameter increases or decreases the field current at the armature current that is halfway between the Field Map Start current and the controller's programmed current limit.

**Fig. 18** Field current relative to armature current, with field map parameter set at 50% and 25%.

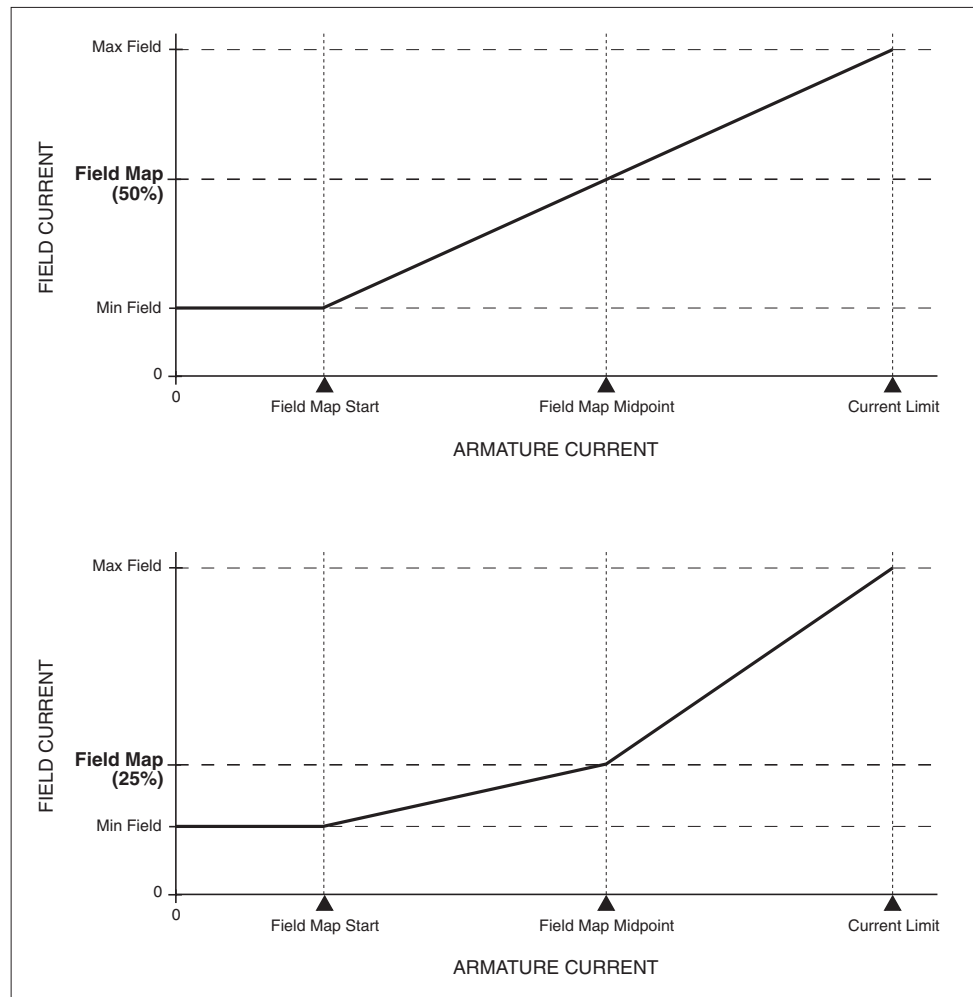

With the Field Map set at 50% and the Field Map Start set at zero, the motor's field current increases linearly with increasing armature current—thus emulating a series wound motor. Decreasing the Field Map setting reduces the field current at a given armature current, i.e., it weakens the field. As the field current is reduced, the motor will be able to maintain speeds closer to the maximum speed value.

Care should be taken to ensure that excessively low Field Map values do not move the motor's operating characteristics outside its safe commutation region.

### ***CAN-NODES Parameters***

*The 1254 controller is available in models that are compatible with CAN Bus communications systems. For information on the CAN-Nodes protocol that Curtis uses in its CAN Bus controller models, refer to the Curtis CAN Protocol Document—available from local Curtis offices.*

#### **NODES**

The **nodes option** parameter enables the CAN Nodes bus interface. This parameter is valid only when the optional CAN Bus function has been specified for the controller.

#### **NODE ADDR**

The **node address** parameter determines which address the controller will respond to when used with a CAN Bus communications system. The address can be specified from 1 to 15. This parameter is valid only when the optional CAN Bus function has been specified for the controller.

# 4

## INSTALLATION CHECKOUT

Carefully complete the following checkout procedure before operating the hydraulic system. If you find a problem during the checkout, refer to the diagnostics and troubleshooting section (Section 6) for further information.

The installation checkout can be conducted with or without the handheld programmer. The checkout procedure is easier with a programmer. Otherwise, observe the Status LED (located in the controller's label area) for diagnostic codes. The codes are listed in Section 6.

Before starting the procedure, check that the hydraulic hoses are secure, and the system primed with oil.



**Drive the vehicle to a location that will provide enough room for all the hydraulic functions to be tested; if indoors, be sure the ceiling height is adequate.**

**Do not stand, or allow anyone else to stand, directly in front of or beside the vehicle during the checkout.**

**Make sure the keyswitch is off, the throttles are in neutral, and all the hydraulic system switches (Lift, Lower, Reach, Tilt, Shift, Rotate, etc.) are open.**

**Wear safety glasses and use well-insulated tools.**

1. If a programmer is available, connect it to the programmer connector.
2. Turn the keyswitch on. The programmer should power up with an initial display, and the controller's Status LED should begin steadily blinking a single flash. If neither happens, check for continuity in the keyswitch circuit and controller ground.
3. If you are using a programmer, put it into the diagnostic mode by pressing the **DIAGNOSTICS** key. The display should indicate "No Known Faults." Close the interlock switch (if one is used in your application). The Status LED should continue blinking a single flash and the programmer should continue to indicate no faults.

If there is a problem, the LED will flash a diagnostic code and the programmer will display a diagnostic message. If you are conducting the checkout without a programmer, look up the LED diagnostic code in Section 6 (Diagnostics and Troubleshooting).

When the problem has been corrected, it may be necessary to cycle the keyswitch in order to clear the fault.

4. *Separately Excited Motor Applications Only:* With the interlock switch closed, select an operation and either apply throttle or use the appropriate speed select switch. Observe the action of the pump, which is uni-directional. If it does not spin in the proper direction, turn off the controller, disconnect the battery, and exchange the motor's field connections (the **F1** and **F2** cables) on the controller. The motor should now turn in the proper direction.
5. If you are using a programmer, put it into the test mode by pressing the **TEST** key. Scroll down to observe the status of the Lift, Lower, interlock, and six speed select switches (SS1–SS6). Cycle each switch in turn, observing the programmer. The programmer should display the correct status for each switch.
6. Using Throttle 1 (or the multifunction control handle, if applicable), operate the Lift and Lower. They should accelerate and decelerate smoothly.
7. Similarly, test the functions controlled by Throttle 2 and Throttle 3 (if applicable).
8. Verify that Startup Lockout performs as desired.
9. Request multiple operations in various combinations, to confirm that motor speed responds according to the settings you made for the SS Add Mode, Throttle Add Mode, and Final Add Mode parameters.
10. If you used a programmer, disconnect it when you have completed the checkout procedure.

## BENCH TESTING WITH THE 1307 PROGRAMMER

With the simple bench test setup shown in Figure 19, the controller parameters can be verified or adjusted without the controller being wired into a vehicle. The wiring can be expanded to conduct a complete functional test on the bench; if you want to do this, contact Curtis for further information.

The complete in-vehicle installation checkout, as described above in Steps 1–10, should still be conducted before the vehicle is operated.

**Fig. 19** Bench test setup for verifying and adjusting the controller's parameters.

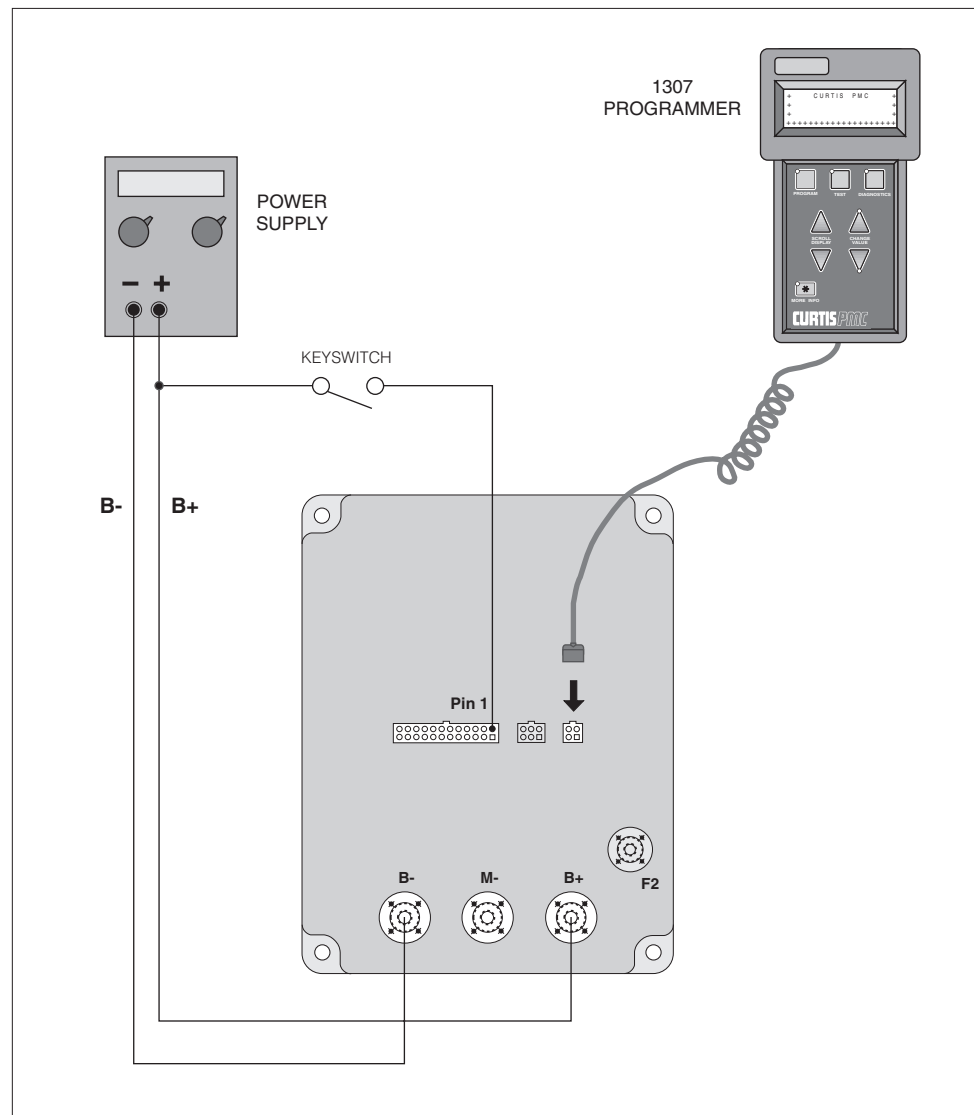

# 5

## PROGRAMMER OPERATION

The universal 1307 Curtis handheld programmer (optional) allows you to program, test, and diagnose Curtis programmable controllers. The programmer is powered by the host controller, via the modular connector located on the front of the controller.

When it is first plugged into the controller, the programmer displays the controller's model number, date of manufacture, and software revision code. Following this initial display, the programmer displays a prompt for further instructions.

NOTE: This controller was developed for use with the 1307 handheld programmer. The 1307 has been superseded; if you are using a more recent programmer, please refer to the appropriate documentation.

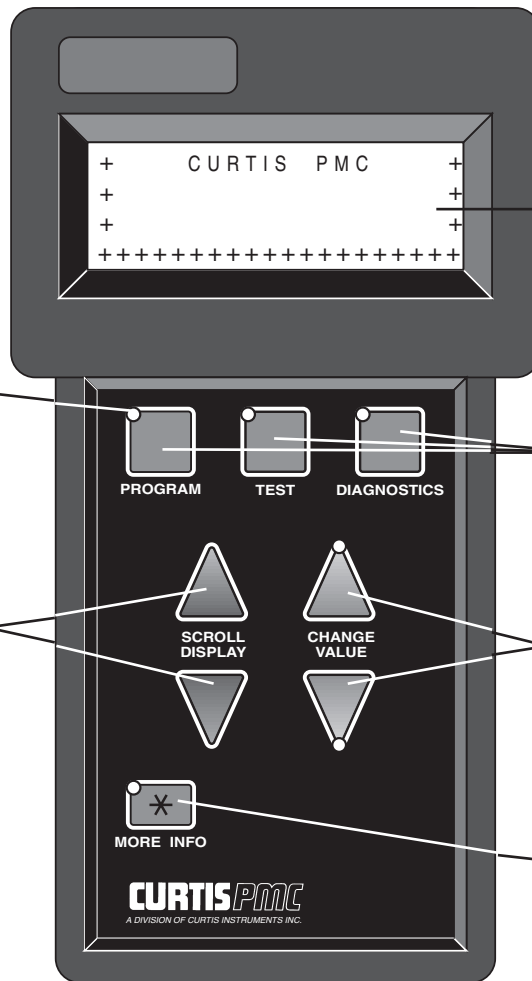

A 4-line LCD display is presented in this window

The LED in the corner of the key lights up to identify the mode of operation

Choose the Program, Test, or Diagnostics Mode with one of these three keys

Scroll the 4-line display (up and down) with these two keys

Change the selected item's value (up or down) with these two keys

Get more information about selected items with this key. Also, use this key in combination with other keys to put the programmer in Special modes.



The programmer is operated via an 8-key keypad. Three keys select operating modes (Program, Test, Diagnostics), two scroll the display up and down, and two change the values of selected parameters. The eighth key, the **[MORE INFO]** key, is used to display further information about selected items within any of the three standard modes. In addition, when pressed together with the **[PROGRAM]** or the **[DIAGNOSTICS]** key, the **[MORE INFO]** key selects the Special Program mode or the Special Diagnostics mode.

The display window presents a 4-line LCD display. The display is visible even in bright sunlight. You can adjust the display contrast in the Special Program mode.

When one of the menu keys is pressed, the LED at the corner of the key lights up, identifying the mode of programmer operation. For example, if the **[TEST]** key is pressed, the LED at the corner of the key indicates that the programmer is now in the Test mode, and the Test Menu is displayed.

Four lines of a menu are displayed at a time. The item at the top of the display window is the selected item. To select an item, scroll within the menu until the desired item is positioned at the top of the display window. The selected item is always the top line. (In the Program mode, the selected item is highlighted by a flashing arrow.) To modify a parameter or obtain more information about it, it must be scrolled to the top position in the display window.



To scroll up and down within a menu, use the two **[SCROLL DISPLAY]** arrow keys. The **[SCROLL DISPLAY]** arrow keys can be pressed repeatedly or be held down. When a key is held down, the scrolling speed increases the longer the key is held.

A small scroll bar at the left of the display window provides a rough indication of the position of the four displayed items within the entire menu. That is, when the bar is at the top of the window, the top of the menu is displayed. As you scroll through the menu, the bar moves downward. When the bar is at the very bottom of the window, you have reached the end of the menu. This sample display is from the Program Menu:

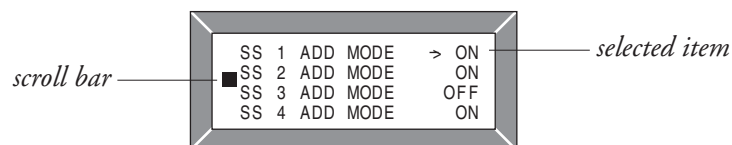



The two **CHANGE VALUE** arrow keys are used to increase or decrease the value of a selected menu item. Like the **SCROLL DISPLAY** arrow keys, the **CHANGE VALUE** arrow keys can be pressed repeatedly or be held down. The longer a key is held, the faster the parameter changes. This allows rapid changing of any parameter.

An LED on each **CHANGE VALUE** arrow key indicates whether the key is active and whether change is permissible. When the value of a parameter is being increased, the LED on the “up” **CHANGE VALUE** key is on until you reach the maximum value for that parameter. When the LED goes off, you cannot increase the value.

The **MORE INFO** key has three functions: (1) to display more information about the selected item, (2) to access the Special Program and Special Diagnostics modes (when used together with the **PROGRAM** and **DIAGNOSTICS** keys), and (3) to initiate certain commands (such as the Self Test).

“More information” is available in all of the programmer operating modes. After using the **MORE INFO** key to display additional information about the selected item, press the **MORE INFO** key again to return to the original list.

## OPERATING MODES:

PROGRAM, TEST, DIAGNOSTICS, SPECIAL PROGRAM, SPECIAL DIAGNOSTICS

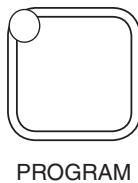

In the **Program** mode, accessed by pressing the **PROGRAM** key, all the adjustable parameters and features of the controller are displayed (four at a time), with their present settings. The setting of the selected item—the item at the top of the display, with the flashing arrow—can be changed, using the two **CHANGE VALUE** keys.

The LEDs on these keys indicate whether there is still room for change. That is, when the upper limit of a parameter’s range is reached, the LED on the “up” key no longer lights up, indicating that the present value cannot be increased; when the lower limit is reached, the LED on the “down” key no longer lights up.

The **MORE INFO** key, when used in the Program mode, displays a bar graph along with the minimum and maximum values possible for the selected parameter. Parameters can be changed either from the main Program Menu or after the **MORE INFO** key has been pressed and the additional information is being displayed (see example below).

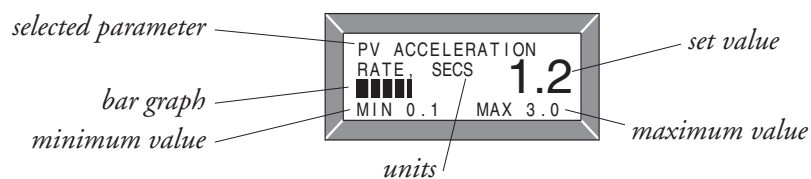

The Program Menu is presented at the end of this section. NOTE: Some items may not be available on all 1254 models.

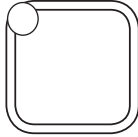

TEST

In the **Test** mode, accessed by pressing the **TEST** key, real-time information is displayed about the status of the inputs, outputs, and controller temperature. For example, when the status of the forward switch is displayed, it should read “On/Off/On/Off/On/Off” as the switch is repeatedly turned on and off. In the Test mode, the item of interest does not need to be the top item on the list; it only needs to be among the four items visible in the window. The Test mode is useful for checking out the operation of the controller during initial installation, and also for troubleshooting should problems occur.

The **MORE INFO** key, when used in the Test mode, causes additional information to be displayed about the selected item (top line in the window).

The Test Menu is presented at the end of this section. NOTE: Some items may not be available on all 1254 models.



DIAGNOSTICS

In the **Diagnostics** mode, accessed by pressing the **DIAGNOSTICS** key, currently active faults detected by the controller are displayed.

The **MORE INFO** key, when used in the Diagnostics mode, causes additional information to be displayed about the selected item.

A list of the abbreviations used in the Diagnostics display is included at the end of this section.

The **Special Program** mode allows you to perform a variety of tasks, most of which are self-explanatory. Through the Special Program Menu, you can revert to earlier settings, save controller settings into the programmer memory, load the controller settings from the programmer into a controller, clear the controller’s diagnostic history, adjust the contrast of the programmer’s LCD display, select the language to be displayed by the programmer, and display basic information (model number, etc.) about the controller and the programmer.

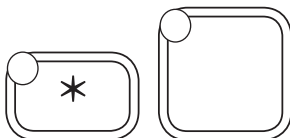

MORE INFO

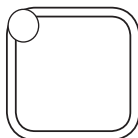

PROGRAM

To access the Special Program mode, first press the **MORE INFO** key. Then, while continuing to hold the **MORE INFO** key, press the **PROGRAM** key. The LED on the **PROGRAM** key will light, just as when the programmer is in Program mode. To distinguish between the Program and Special Program modes, look at the menu items in the display.

#### CONTROLLER CLONING

Two of the Special Program Menu items—“CONT SETTINGS → PROG” and “PROG SETTINGS → CONT”—allow you to “clone” controllers. To do this, simply program one controller to the desired settings, save these settings in the programmer, and then load them into other similar (same model number) controllers, thus creating a family of controllers with identical settings.

The **MORE INFO** key is used initially to access the Special Program mode, and once you are within the Special Program mode, it is used to perform the desired tasks. To adjust the contrast in the display window, for example, select “Contrast Adjustment” by scrolling until this item is at the top of the screen, and then press **MORE INFO** to find out how to make the adjustment.

The Special Program Menu is presented at the end of this section.

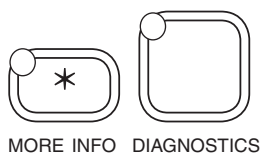

In the **Special Diagnostics** mode, the controller’s diagnostic history file is displayed. This file includes a list of all faults observed and recorded by the controller since the history was last cleared. (NOTE: The maximum and minimum temperatures recorded by the controller are included in the Test Menu.) Each fault is listed in the diagnostic history file only once, regardless of the number of times it occurred.

To access Special Diagnostics, first press the **MORE INFO** key. Then, while continuing to hold the **MORE INFO** key, press the **DIAGNOSTICS** key. The LED on the **DIAGNOSTICS** key will light, just as when the programmer is in Diagnostics mode.

The **MORE INFO** key, when used within the Special Diagnostics mode, causes additional information to be displayed about the selected item.

To clear the diagnostic history file, put the programmer into the Special Program mode, select “Clear Diagnostic History,” and press the **MORE INFO** key for instructions. Clearing the diagnostic history file also resets the maximum/minimum temperatures in the Test Menu.

## PEACE-OF-MIND PROGRAMMING

Each time the programmer is connected to the controller, it acquires all the controller’s parameters and stores them in its temporary memory. You can revert back to these original settings at any time during a programming session via the Special Program Menu. Select “Reset All Settings” by scrolling it to the top of the display window, press the **MORE INFO** key, and follow the instructions displayed. Any inadvertent changing of parameters can be “undone” using this procedure—even if you can’t remember what the previous settings were—**as long as the programmer has not been unplugged and power has not been removed from the controller.**

### Programmer Self Test

You can test the programmer by displaying two special test screens. Press the **MORE INFO** key while the programmer is powering up. During the Self Test, you can toggle between the two test screens by pressing the **SCROLL DISPLAY** keys. The first screen turns on every LCD element, and the second screen displays all the characters used in the various menus. As part of the Self Test, you can also test the keys by pressing each one and observing whether its corner LED lights up. To exit the Self Test, unplug the programmer or turn off the controller, and then re-power it without holding the **MORE INFO** key.

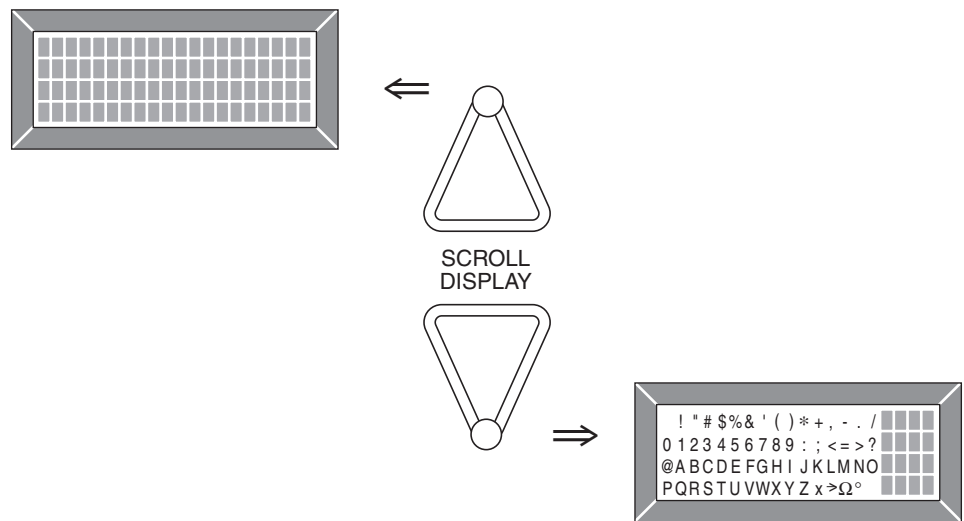

## PROGRAMMER MENUS

Items are listed for each menu in the order they appear in the actual menus displayed by the handheld programmer.

### **Program Menu** (not all items available on all controllers)

P V G A I N	PV current sensor calibration
C U R R E N T L I M I T	Armature current limit, in amps
V O L T A G E	Nominal operating voltage <sup>1</sup>
S S 1 S P E E D	Speed Select 1 max. speed, as % armature PWM
S S 2 S P E E D	Speed Select 2 max. speed, as % armature PWM
S S 3 S P E E D	Speed Select 3 max. speed, as % armature PWM
S S 4 S P E E D	Speed Select 4 max. speed, as % armature PWM
S S 5 S P E E D	Speed Select 5 max. speed, as % armature PWM
S S 6 S P E E D	Speed Select 6 max. speed, as % armature PWM
L I F T M A X S P E E D	Lifting max. speed, as % armature PWM
L O W R M A X S P E E D	Lowering max. speed, as % PV max. current
T H R 2 M A X S P E E D	Throttle 2 max. speed, as % armature PWM
T H R 3 M A X S P E E D	Throttle 3 max. speed, as % armature PWM
M I N I M U M S P E E D	Minimum speed, as % armature PWM
S S A C C E L R A T E	Acceleration rate for SS 1-6, in seconds
S S D E C E L R A T E	Deceleration rate for SS 1-6, in seconds
T H R O T T L E A C C E L	Acceleration rate for Throttles 1-3, in seconds
T H R O T T L E D E C E L	Deceleration rate for Throttles 1-3, in seconds
T H R O T T L E T Y P E	Throttle input signal type <sup>2</sup>
T H R O T T L E M A P	Throttle map for Throttles 1-3
D E A D B A N D	Neutral deadband, as % of throttle range
T H R O T T L E M A X	% of throttle movement at which 100% output occurs
T H R T L 1 F A U L T	Throttle 1 fault signal: On or Off
T H R T L 2 F A U L T	Throttle 2 fault signal: On or Off
T H R T L 3 F A U L T	Throttle 3 fault signal: On or Off
M U L T I F U N C T I O N	Scaling of SS 1-3 with Throttle 1: On or Off
S S 1 A D D M O D E	Add Mode for Speed Select 1: On or Off
S S 2 A D D M O D E	Add Mode for Speed Select 2: On or Off
S S 3 A D D M O D E	Add Mode for Speed Select 3: On or Off
S S 4 A D D M O D E	Add Mode for Speed Select 4: On or Off
S S 5 A D D M O D E	Add Mode for Speed Select 5: On or Off
S S 6 A D D M O D E	Add Mode for Speed Select 6: On or Off
T H R T L A D D M O D E	Add Mode for Throttles 1-3: On or Off
F I N A L A D D M O D E	Final Add Mode: On or Off

(Menu continues on next page.)

**Program Menu, cont'd**

COMPENSATION	Load compensation: 0 to 25%
CURRENT RATIO	Current ratio: 1 (1×), 2 (2×), 3 (4×), or 4 (8×)
LIFT LOCKOUT	Lift lockout: On or Off
START LOCKOUT	Startup lockout type <sup>3</sup>
MIN SPD DISABL	Minimum speed enabled: On or Off
CONTACT CNTRL	Contactoer control type <sup>4</sup>
CONT DELAY	Contactoer open delay: On or Off
SEQUENCING DLY	Sequencing delay, in seconds
CONT DIAG	Contactoer diagnostics enabled: On or Off
VALVE CNTRL	PV and load-hold valve enabled: On or Off
COIL CHECK	Check for open coil on PV solenoid: On or Off
PV MAX CURR	Maximum current for proportional valve, in amps
PV MIN CURR	Minimum current for proportional valve, in amps
PV DITHER	$I_{PVcoil}$ dither for PV, in % PV max. current
PV ACCEL	Acceleration rate for PV current, in seconds
PV DECEL	Deceleration rate for PV current, in seconds
LOAD HOLD DLY	Delay after Lift/Lower, in seconds
SEPEX	Separately excited motor option: On or Off
MAX FIELD	Maximum field current, in amps
MIN FIELD	Minimum field current, in amps
FLD MAP START	Armature current at which field current starts increasing, in amps
FIELD MAP	Field current at midpoint of armature current, in %
FAULT CODE	Fault output type <sup>5</sup>
NODES	CAN Nodes bus interface: On or Off
NODES ADDR	CAN-Bus address: 1 through 15
PRECHARGE	Precharge function: On or Off

## Program Menu Notes

<sup>1</sup> Nominal operating voltage settings

- 2: 24 V
- 3: 36 V
- 4: 48 V
- 5: 60 V
- 6: 72 V
- 7: 84 V

<sup>2</sup> Throttle types (see Throttle Wiring in Section 2)

- Type 1:* 5k $\Omega$ –0 pots
- Type 2:* single-ended 0–5V, 3-wire pots, current sources, and electronic throttles
- Type 3:* 0–5k $\Omega$  pots
- Type 4:* wigwag 0–5V, voltage sources, and 3-wire pots
- Type 5:* CAN-Nodes controls

<sup>3</sup> Startup lockout types (see Section 3: Programmable Parameters, page 34)

- Type 0:* no startup lockout
- Type 1:* startup lockout unless KSI input is received before speed request
- Type 2:* startup lockout unless KSI and interlock inputs are both received before speed request

<sup>4</sup> Pump contactor control types (see Section 3: Programmable Parameters, page 36)

- Type 0:* no preconditions
- Type 1:* KSI required
- Type 2:* KSI and interlock input both required

<sup>5</sup> Fault output types (see Section 3: Programmable Parameters, page 35)

- On:* Fault Code format
- Off:* Fault Category format



**Test Menu** (not all items available on all controllers)

T H R O T T L E 1	Throttle 1 reading, as %
T H R O T T L E 2	Throttle 2 reading, as %
T H R O T T L E 3	Throttle 3 reading, as %
A R M C U R R E N T	Motor armature current, in amps
A R M P W M	Motor armature appl'd duty cycle, as %
F L D C U R R E N T	Motor field current, in amps
F I E L D P W M	Motor field applied duty cycle, as %
P V C U R R E N T	Proportional valve current, in amps
P V P W M	Proportional valve appl'd duty cycle, as %
C A P V O L T A G E	Voltage at controller's B+ bus bar
B A T T V O L T A G E	Voltage at KSI
H E A T S I N K T E M P	Heatsink temperature, in °C
L O W E R I N P U T	Lower switch: on/off
L I F T I N P U T	Lift switch: on/off
I N T R L C K I N P U T	Interlock switch: on/off
S S 1 I N P U T	Speed Select 1 switch: on/off
S S 2 I N P U T	Speed Select 2 switch: on/off
S S 3 I N P U T	Speed Select 3 switch: on/off
S S 4 I N P U T	Speed Select 4 switch: on/off
S S 5 I N P U T	Speed Select 5 switch: on/off
S S 6 I N P U T	Speed Select 6 switch: on/off
L O A D H O L D	Load-hold valve: on/off
P U M P C O N T A C T O R	Pump contactor: open/closed
F A U L T 1	Fault 1 driver status: on(low)/off(high)
F A U L T 2	Fault 2 driver status: on(low)/off(high)

### **Special Program Menu**

R E S E T   A L L   S E T T I N G S	Revert to original settings
C O N T   S E T T I N G S >   P R O G	Save controller settings in programmer
P R O G   S E T T I N G S >   C O N T	Load programmer settings in controller
C L E A R   D I A G   H I S T O R Y	Clear diagnostic history memory
C O N T R A S T   A D J U S T M E N T	Adjust display contrast
L A N G U A G E   S E L E C T I O N	Select displayed language
P R O G R A M M E R   I N F O	Display programmer information
C O N T R O L L E R   I N F O	Display controller information

### **Diagnostics and Special Diagnostics “Menu”**

This is not a menu as such, but simply a list of the possible messages you may see displayed when the programmer is operating in either of the Diagnostics modes. The messages are listed here in alphabetical order for easy reference.

A R M   S E N S O R	Armature current sensor fault
P U M P   C O N T   D N C	Pump contactor did not close or missing
C O N T   D R V R   O C	Pump contactor driver overcurrent
P U M P   C O N T   W E L D E D	Pump contactor welded
F I E L D   O P E N	Field winding open or disconnected
F L D   S E N S O R	Field current sensor fault
H W   F A I L S A F E	Power-on self test fault
L I F T   L O C K O U T	Undervoltage during Lift operation
L O W   B A T T E R Y   V O L T A G E	Battery voltage too low
M -   S H O R T E D	M- output shorted to B-
N O   K N O W N   F A U L T S	No known faults
O V E R V O L T A G E	Battery voltage too high
P R E C H A R G E   F A U L T	Precharge fault
P V   C O I L   O P E N	Proportional valve solenoid coil open
S E Q U E N C E   E R R O R	Startup lockout feature activated
T H E R M A L   C U T B A C K	Cutback, due to over/under temp
T H R O T T L E   1   F A U L T	Problem with Throttle 1 or its wiring
T H R O T T L E   2   F A U L T	Problem with Throttle 2 or its wiring
T H R O T T L E   3   F A U L T	Problem with Throttle 3 or its wiring

# 6

## DIAGNOSTICS AND TROUBLESHOOTING

The 1254 controller provides diagnostics information to assist technicians in troubleshooting pump system problems. The diagnostics information can be obtained by observing the appropriate display on the handheld programmer, the fault codes issued by the Status LED, or the fault display driven by the controller's Fault 1 and Fault 2 outputs. Refer to the troubleshooting chart (Table 5) for suggestions covering a wide range of possible faults.

### PROGRAMMER DIAGNOSTICS

The programmer presents complete diagnostic information in plain language. Faults are displayed in the Diagnostic Menu (see column 2 in the troubleshooting chart), and the status of the controller inputs/outputs is displayed in the Test Menu.

Accessing the Diagnostic History Menu provides a list of the faults that have occurred since the diagnostic history file was last cleared. Checking (and clearing) the diagnostic history file is recommended each time the vehicle is brought in for maintenance.

The following 4-step process is recommended for diagnosing and troubleshooting an inoperative pump system: (1) visually inspect the vehicle for obvious problems; (2) diagnose the problem, using the programmer; (3) test the circuitry with the programmer; and (4) correct the problem. Repeat the last three steps as necessary until the pump system is operational.

**Example:** A vehicle that cannot perform Lifting operations is brought in for repair.

STEP 1: Examine the vehicle and its wiring for any obvious problems, such as broken wires or loose connections.

STEP 2: Connect the programmer, select the Diagnostics Menu, and read the displayed fault information. In this example, the display shows "No Known Faults," indicating that the controller has not detected anything out of the norm.

STEP 3: Select the Test Menu, and observe the status of the Lift input. In this example, the display shows that the Lift switch did not close when "Lift" was selected, which means the problem is either in the Lift switch or the switch wiring.

STEP 4: Check or replace the Lift switch and wiring and repeat the test. If the programmer shows the Lift switch closing and the system now operates normally, the problem has been corrected.

**Table 5 TROUBLESHOOTING CHART**

LED CODE	PROGRAMMER LCD DISPLAY	FAULT CATEGORY	EXPLANATION	POSSIBLE CAUSE
1,2	HW FAILSAFE	1	self-test or watchdog fault	1. Controller defective.
1,3	M- SHORTED	1	M- output shorted to B-	1. Controller defective, or external short.
	FIELD OPEN	1	field winding fault	1. Motor field wiring loose. 2. Motor field winding open, or high resistance.
	ARM SENSOR	1	armature current sensor fault	1. Controller defective.
	FLD SENSOR	1	field current sensor fault	1. Controller defective.
1,4	PV COIL OPEN	1	proportional valve solenoid coil open	1. Connection to solenoid loose. 2. Controller defective.
2,1	THROTTLE (#) FAULT	1	Throttle 1, 2, or 3 signal out of range	1. Throttle input wire open. 2. Throttle input wire shorted to B+ or B-. 3. Defective throttle. 4. Wrong throttle input signal type selected.
2,2	LIFT LOCKOUT	3	undervoltage during Lift	1. Low battery voltage.
2,3	SEQUENCE ERROR	3	sequencing error	1. Improper sequence of throttle input and KSI or interlock input. 2. Wrong startup lockout type selected. 3. Misadjusted throttle. 4. Sequencing delay too short.
3,1	CONT DRVR OC	1	pump cont. driver overcurrent	1. Pump contactor coil shorted.
3,2	PUMP CONT WELDED	1	pump contactor welded	1. Pump contactor stuck closed. 2. Pump contactor driver shorted.
3,3	PRECHARGE FAULT	1	internal voltage too low at startup	1. Controller defective. 2. External short, or leakage path to B- on external B+ connection.
3,4	PUMP CONT DNC	1	contactor did not close or missing	1. Pump contactor tips not connected. 2. Open cable to/from contactor terminals.
4,1	LOW BATTERY VOLTAGE	2	low battery voltage	1. Battery voltage <undervoltage cutback limit. 2. Corroded battery terminal. 3. Loose battery or controller terminal.
4,2	OVERVOLTAGE	2	overvoltage	1. Battery voltage >overvoltage shutdown limit. 2. Operation with charger attached.
4,3	THERMAL CUTBACK	2	over-/under-temperature cutback	1. Temperature >85°C or <-25°C. 2. Excessive load on pump motor. 3. Improper mounting of controller. 4. Operation in extreme environments.

## LED DIAGNOSTICS

A Status LED is built into the 1254 controller. It is visible through a window in the label on top of the controller. This Status LED displays fault codes when there is a problem with the controller or with the inputs to the controller. During normal operation, with no faults present, the Status LED flashes steadily on and off. If the controller detects a fault, a 2-digit fault identification code is flashed continuously until the fault is corrected. For example, code “3,2”—welded pump contactor—appears as:

aaa aa ( 3 , 2 )	aaa aa ( 3 , 2 )	aaa aa ( 3 , 2 )
---------------------	---------------------	---------------------

The codes are listed in Table 6.

LED CODES		EXPLANATION
<i>LED off</i>	████████	no power or defective controller
<i>solid on</i>	□□□□	controller or microprocessor fault
0,1	■ □	controller operational; no known faults
1,1	□ □	[not used]
1,2	□ □□	hardware failsafe fault
1,3	□ □□□	M-, current sensor, or motor fault
1,4	□ □□□□	proportional valve solenoid coil open
2,1	□□ □	throttle 1-2-3 input signal fault
2,2	□□ □□	lift lockout
2,3	□□ □□□	sequence error fault (startup lockout)
2,4	□□ □□□□	[not used]
3,1	□□□ □	pump contactor driver overcurrent
3,2	□□□ □□	welded pump contactor
3,3	□□□ □□□	precharge fault
3,4	□□□ □□□□	pump contactor missing or did not close
4,1	□□□□ □	low battery voltage
4,2	□□□□ □□	overvoltage
4,3	□□□□ □□□	thermal cutback, due to over/under temp.
4,4	□□□□ □□□□	[not used]

NOTE: Only one fault is indicated at a time, and faults are not queued up. Refer to the troubleshooting chart (Table 5) for suggestions about possible causes of the various faults.

## FAULT OUTPUT DRIVERS

The 1254 controller provides two fault output drivers designed for use with a display to provide fault information to the operator. The fault output drivers, Fault 1 (Pin 5) and Fault 2 (Pin 6), are open collector drivers rated at 10 mA maximum current at the nominal battery voltage. They are intended to drive display LEDs but can be used to drive anything that operates within the drivers' limits. These outputs can be configured to display faults in Fault Code format or Fault Category format—see *Section 3, page 35*.

In **Fault Code** format, the two fault outputs operate independently. The Fault 1 line flashes the same codes, at the same time, as the controller's built-in Status LED (see Table 6). This line can therefore be used to drive an LED located on the display panel in order to provide fault code information directly to the operator. The Fault 2 line pulls to ground (B-) when a fault is present; it can be used to drive a remote LED that simply indicates whether or not there is a fault. When no faults are present, both of the fault lines are in their normal state (high).

In **Fault Category** format, the two fault outputs together define one of four fault categories, as listed in Table 7. When a fault occurs, the Fault 1 and Fault 2 lines (Pins 5 and 6) go to the state indicating the category of the particular fault: **LOW/HIGH**, **HIGH/LOW**, or **LOW/LOW**. When the fault is cleared, the fault outputs return to their normal state (i.e., **HIGH/HIGH**).

FAULT 1 DRIVER	FAULT 2 DRIVER	FAULT CATEGORY	DESCRIPTION
HIGH	HIGH	0	(no known faults)
<b>LOW</b>	HIGH	1	Hardware/wiring fault: — hardware failsafe fault — M-, current sensor, or motor fault — proportional valve solenoid coil open — throttle 1-2-3 input signal fault — pump contactor or contactor driver fault — precharge fault
HIGH	<b>LOW</b>	2	Limitation in progress: — undervoltage — overvoltage — over/under temperature
<b>LOW</b>	<b>LOW</b>	3	Lockout: — lift lockout — sequencing error (startup lockout)

## 7

## MAINTENANCE

There are no user serviceable parts in the Curtis 1254 controller. **No attempt should be made to open, repair, or otherwise modify the controller.** Doing so may damage the controller and will void the warranty.

It is recommended that the controller be kept **clean and dry** that its diagnostics history file be checked and cleared periodically.

## CLEANING

Periodically cleaning the controller exterior will help protect it against corrosion and possible electrical control problems created by dirt, grime, and chemicals that are part of the operating environment and that normally exist in battery powered systems.



**When working around any battery powered system, proper safety precautions should be taken.** These include, but are not limited to: proper training, wearing eye protection, and avoiding loose clothing and jewelry.

Use the following cleaning procedure for routine maintenance. Never use a high pressure washer to clean the controller.

1. Remove power by disconnecting the battery.
2. Discharge the capacitors in the controller by connecting a load (such as a contactor coil) across the controller's **B+** and **B-** terminals.
3. Remove any dirt or corrosion from the power and signal connector areas. The controller should be wiped clean with a moist rag. Dry it before reconnecting the battery.
4. Make sure the connections are tight. Refer to Section 2, page 7, for maximum tightening torque specifications for the battery and motor connections.

## DIAGNOSTIC HISTORY

The handheld programmer can be used to access the controller's diagnostic history file. Connect the programmer, press the **[MORE INFO]** key, and then—while continuing to hold the **[MORE INFO]** key—press the **[DIAGNOSTICS]** key. The programmer will read out all the faults that the controller has experienced since the last time the diagnostic history file was cleared. The faults may be intermittent faults, faults caused by loose wires, or faults caused by operator errors. Faults such as contactor faults may be the result of loose wires; contactor wiring should be carefully checked. Faults such as startup lockout or overtemperature may be caused by operator habits or by overloading.

After a problem has been diagnosed and corrected, it is a good idea to clear the diagnostic history file. This allows the controller to accumulate a new file of faults. By checking the new diagnostic history file at a later date, you can readily determine whether the problem was indeed fixed.

To clear the diagnostic history file, go to the Special Program Menu by pressing and holding the **[MORE INFO]** key, and then pressing the **[PROGRAM]** key. Scroll through the menu until “Clear Diagnostic History” is the top line in the display, and then press **[MORE INFO]** again. The programmer will prompt you to acknowledge or cancel. See Section 5 of this manual for more detail on programmer operation.



## APPENDIX A

### GLOSSARY OF FEATURES AND FUNCTIONS

#### Acceleration rate

The acceleration rate is the time required for the controller to increase output from 0 to the maximum allowed. There are two programmable acceleration rates for the 1254 controller: the throttle accel rate (*see Section 3, page 26*), which determines how quickly the controller will provide maximum PWM output in response to full throttle, and the PV current accel rate (*see Section 3, page 39*), which determines how quickly the controller will provide the current necessary to completely open the proportional valve in response to full throttle “Lower.”

#### Access rights

Each programmable parameter is assigned an access level—OEM or User—that defines who is allowed to change that parameter. These levels are assigned by the OEM when the controller is originally specified; if the OEM so desires, some programmable parameters can be assigned factory-only access rights. Restricting parameter access to the OEM reduces the likelihood of important performance characteristics being changed by someone unfamiliar with the hydraulic system’s operation. In some cases, it may be necessary to restrict a parameter’s access to ensure that it is not set to a value in violation of EEC or other safety regulations. The 1307M-1101 User programmer can adjust only those parameters with User access. The 1307M-2101 OEM programmer can adjust all the parameters with User or OEM access rights. Typically, OEMs supply 1307M-1101 programmers to their dealers and distributors so that the User-access parameters (for example, the throttle acceleration rate and the maximum speeds) can be set to each customer’s liking, and so that the programmer’s testing and diagnostics capabilities can be used.

#### CAN Bus

CAN (Controller Area Network) Bus provides a two-wire communications system. It is widely used in automotive applications and is also well suited to electrically controlled material handling systems. Use of the CAN Bus system considerably reduces the complexity of the wire harness. Additionally, the CAN Bus communications protocol provides error and fault detection to ensure proper signal and command transmission and reception. The CAN Bus system carries a high level of immunity to electromagnetic interference, as well. For information regarding the CAN-Nodes protocol that Curtis uses in its controllers, refer to the Curtis CAN Protocol Document—available from local Curtis offices.

### **Current limiting**

Curtis controllers limit the motor current to a preset maximum—*see Section 3, page 40*. This feature protects the controller from damage that might result if the current were limited only by motor demand. PWM output to the armature and field power sections is reduced until the motor current falls below the set limit level.

In addition to protecting the controller, the current limit feature also provides some protection to the rest of the system. By eliminating high current surges during acceleration, stress on the motor and batteries is reduced and their efficiency enhanced.

### **Current ratio**

The 1254 controller's current limit increases with increased throttle, according to an algorithm developed to produce smooth starts and good overall handling characteristics. The current ratio parameter allows the OEM to adjust the amount of current available at low speed requests in order to provide improved performance with heavy loads at partial throttle if that is desired for a specific application—*see Section 3, page 41*.

### **Decel rate**

The throttle decel (*see Section 3, page 26*) and PV current decel (*see Section 3, page 40*) parameters work similarly to their accel counterparts, as summarized in the Accel Rate entry. The deceleration rate is the time required for the controller to decrease output from the maximum allowed to 0.

### **Environmental protection**

The 1254 controller is housed in a rugged ABS plastic case providing environmental protection that meets the requirements of IP64 / IP67. The controller should be kept clean and dry to ensure long life. Additional protection is recommended if the controller is mounted in a location exposed to dirt or water splash.

### **ET-series electronic throttles**

The ET-XXX is a wigwag-style throttle control assembly. It provides a 0–5V signal in both directions (Lift, Lower). Use of this throttle control assembly requires that the controller's throttle input be configured for a Type 2 (single-ended 0–5V) throttle.

### **Fault categories**

The 1254 controller is equipped with two fault drivers. These drivers can be configured to provide information in “fault category” or “fault code” format.

If the drivers are configured in “fault category” format, they will indicate one of three categories of faults. The Fault Categories are defined in Table 7—*see Section 6, page 62.*

### **Fault codes**

The 1244 controller provides fault information by flashing Fault Codes. When a fault occurs, the fault code can be read directly from the Status LED built into the controller’s cover. In addition, the controller has two output drivers that can be configured to provide information in “fault category” or “fault code” format. If the drivers are configured in “fault code” format, they will drive fault indicator LEDs located on a remote panel. The information displayed by these remote panel LEDs will be identical to that displayed by the controller’s built-in Status LED. The Fault Codes are defined in Table 6—*see Section 6, page 61.*

### **Fault detection and response**

An internal microcontroller automatically maintains surveillance over the functioning of the controller. When a fault is detected, the appropriate fault code is signalled via the controller’s built-in Status LED, which is externally visible through the label on top of the controller. If the fault is critical, the controller is disabled. More typically, the fault is a remediable condition and temporary. The faults covered by the 1254 controller’s automatic fault detection system are listed in Table 5—*see Section 6, page 60.*

### **Fault recording**

Fault events are recorded in the controller’s diagnostic history file. Multiple occurrences of the same fault are recorded as one occurrence. This fault event list can be loaded into the programmer for readout. The programmer’s Special Diagnostics mode provides access to the controller’s diagnostic history file—the entire fault event list created since the diagnostic history file was last cleared. The Diagnostics mode, on the other hand, provides information about only the currently active faults.

### **Fault recovery (including recovery from disable)**

Almost all faults require a cycling of the keyswitch or interlock switch to reset the controller and enable operation. The only exceptions are these:

FAULT	RECOVERY
startup lockout	when proper sequence is followed
overvoltage	when battery voltage drops below overvoltage threshold
thermal cutback	when temperature returns to the acceptable range
throttle faults	when input signal returns to the acceptable range
undervoltage	when battery voltage rises above undervoltage threshold
<i>(all other faults)</i>	<i>(cycle keyswitch or interlock switch)</i>

**Field map** — SEPEX CONTROLLERS ONLY

The field map parameter determines the relationship between the shunt field winding current and the armature current. The field map parameter affects throttle acceleration and midrange torque characteristics. This parameter is programmable—see *Section 3, page 43*.

**Field map start** — SEPEX CONTROLLERS ONLY

The field map start parameter defines the armature current at which the field map starts to increase. The field map start parameter is used to help equalize the pump motor's maximum speed when loaded and unloaded. This parameter is programmable—see *Section 3, page 42*.

**Interlock switch**

This switch is a controller-enable input intended to provide a secondary operational interlock for the controller in addition to the keyswitch input. If an interlock switch is used, it must be closed—providing a high signal to the interlock pin (Pin 2)—in order for the controller to operate. This safety interlock is used on most material handling vehicles. Cycling the interlock switch or the keyswitch clears most faults and re-enables operation.

**KSI**

KSI (Key Switch Input) provides power to the controller's logic board, initializes the microprocessor, and starts diagnostics. In combination with the interlock switch input, KSI enables all logic functions.

**Lift lockout**

The lift lockout feature prevents Lift operations during undervoltage conditions—see *Section 3, page 34*.

**Load compensation**

The load compensation feature automatically adjusts the applied motor voltage as a function of motor load current. This results in more constant pump speeds over variations in motor load—without the operator having to constantly adjust the throttle position. The load compensation parameter is programmable—see *Section 3, page 42*.

**M- fault detect**

This feature determines if the M- power connection is being held low (to B-) by an internal or external fault condition. If an M- fault is detected, the controller will inhibit PWM output and release the pump contactor. M- fault detection is not performed if the contactor control parameter is set to "1"—see *Section 3, page 36*.

**MOSFET**

A MOSFET (metal oxide semiconductor field effect transistor) is a type of transistor characterized by its fast switching speeds and very low losses.

**OEM (= Original Equipment Manufacturer)****Overtemperature**

Because of their efficiency and thermal design, Curtis controllers should barely get warm in normal operation. Overheating can occur, however, if the controller is undersized for its application or otherwise overloaded. The 1254 controller constantly monitors its internal heatsink temperature. Starting at 85°C, the armature current is linearly decreased from full set current down to zero at 95°C.

Full current and performance return automatically after the controller cools down. Although occasional overtemperature operation is usually not damaging to the controller, it does suggest a mismatch. If thermal cutback occurs often in normal operation, the controller is probably undersized for the application and a higher current model should be used. Continuous operation in overtemperature will overstress the power components and reduce the lifetime and reliability of the controller.

**Overvoltage protection**

The overvoltage protection feature protects the controller if the voltage exceeds the factory-set limit. Overvoltage can result during battery charging or from an improperly wired controller. As soon as the voltage rises above the overvoltage threshold, the armature current is cut back linearly until it reaches zero at the cutoff point; normal controller operation resumes when the voltage drops below the threshold. The overvoltage threshold and cutoff points are established by the battery voltage parameter, which should be set to the system's nominal battery pack voltage—*see Section 3, page 40*. The overvoltage threshold and cutoff points are listed in Table E-1 at the back of the manual.

**Pump contactor control**

The setting of the pump contactor control parameter allows the pump contactor to be pulled in with the keyswitch or with the interlock; the setting of this parameter also affects whether several other features (e.g., contactor diagnostics, Lift lockout, M- test, precharge) are enabled—*see Section 3, page 36*.

**PV (= Proportional Valve)**

**PWM**

Pulse width modulation (PWM), also called “chopping,” is a technique that switches battery voltage to the motor on and off very quickly, thereby controlling the speed of the motor. Curtis 1200 series controllers use high frequency PWM—in this case, 16 kHz—which permits silent, efficient operation.

**Reverse polarity protection**

Reverse voltage will damage the controller. Reverse polarity protection is provided by including a diode in series with the control line as shown in the standard wiring diagrams, Figures 3 and 4. When this diode is used, reversing the battery’s B+ and B- connections to an otherwise properly wired controller will not allow the pump contactor to be engaged. This protects the controller from being damaged by the reverse polarity.

**Safe commutation region — SEPEX CONTROLLERS ONLY**

The safe commutation region includes all the combinations of field current and armature current that allow proper commutation between the motor’s brushes and the armature. If the motor operates outside this region, arcing and severe heating and brush wear will occur. The motor manufacturer should be able to provide curves defining the safe combinations of field and armature current. We recommend that you obtain these curves and use them when programming the 1254’s field parameters for a particular motor—see *Section 3, pages 42–43*.

**Sequencing delay**

Sequencing delay allows the interlock switch to be momentarily opened within a set time (the sequencing delay) without activating startup lockout or Lift lockout—see *Section 3, page 37*.

**Speed limiting**

The maximum speed can be limited independently for each speed select switch (see *Section 3, page 23*), for Throttle 1’s Lift (*page 24*) and Lower (*page 25*) functions, and for Throttles 2 and 3 (*page 25*).

If your application uses a separately-excited motor, you can also limit maximum speed through the Min Field parameter (see *Section 3, page 42*).

**Startup lockout**

The startup lockout feature prevents the pump motor from running if any of the throttle requests is greater than 25% or if any of the speed select switches (SS1–SS6) is closed when the controller is turned on. Two types of startup lockout are available (along with a “no startup lockout” option). Selection is made with the programmer—see *Section 3, page 34*.

**Status LED**

A Status LED (Light Emitting Diode) is built into the controller. It is visible through the label located on top of the controller. The Status LED flashes a 2-digit fault identification code when a fault is detected by the controller. The fault code continues to flash until the fault has been corrected and the fault condition has been cleared. Clearing the fault condition typically requires cycling KSI for faults detected during startup, and cycling the interlock switch for faults detected during operation. The fault codes are defined in Table 6—see *Section 6, page 61*.

**Temperature compensation for current limits**

Full temperature compensation provides constant current limits throughout the normal operating range (heatsink temperatures of  $-25^{\circ}\text{C}$  to  $+85^{\circ}\text{C}$ ). The temperature sensor that regulates the current limits is also used to calculate the heatsink temperature displayed by the programmer.

**Throttle deadband (neutral deadband)**

The throttle deadband is the pot wiper voltage range that the controller interprets as neutral. The throttle deadband is typically set at 10%. A higher setting increases the neutral range, which can be useful with throttle assemblies that do not return reliably to a well-defined neutral point. The throttle deadband parameter is programmable—see *Section 3, page 26*.

**Throttle map**

The throttle map parameter determines the controller's static throttle map, adjusting the throttle characteristics to suit your specific application and enhance your vehicle's performance. The throttle map parameter modifies the controller's PWM output relative to the requested throttle amount—see *Section 3, page 30*.

**Throttle max**

The throttle max parameter allows accommodation of throttles that do not provide the standard full range of voltage or resistance variation at the throttle input. Reducing the throttle max parameter value allows full controller output with a throttle input less than that specified in Table 1 (page 12). The throttle max parameter can be programmed to fit your specific vehicle's requirements—see *Section 3, page 28*.

**Throttle types**

The 1254 controller accepts a variety of throttle inputs, from up to three throttles (Throttles 1-2-3). The most commonly used single-ended and wigwag throttles ( $5\text{k}\Omega-0$  and  $0-5\Omega$  pots, 3-wire pots, 0-5V throttles, and the Curtis ET-XXX

electronic throttle) can be used simply by selecting the appropriate throttle type in the programmer's Program Menu—see *Section 3, page 24*.

The 1254 controller is also available in models designed to receive throttle signals from a CAN-based communications system—see *Section 3, page 44*.

### **Undertemperature**

If the controller heatsink temperature falls below  $-25^{\circ}\text{C}$ , the armature current is cut back to 50%. At this reduced current, the controller will quickly heat up without damage. When its heatsink temperature rises above  $-25^{\circ}\text{C}$ , full current will become available.

### **Undervoltage protection**

Undervoltage protection automatically cuts back the controller output if battery voltage is detected below the undervoltage threshold at startup, or when the battery voltage is pulled below the threshold by an external load. As soon as the voltage falls below the undervoltage threshold, the armature current is cut back linearly until it reaches zero at the cutoff point; normal controller operation resumes when the voltage rises above the threshold. The undervoltage threshold and cutoff points are established by the battery voltage parameter, which should be set to the system's nominal battery pack voltage—see *Section 3, page 40*. The undervoltage threshold and cutoff points are listed in Table E-1 at the back of the manual.

During normal operation, the controller duty cycle will be reduced when the batteries discharge down to less than the undervoltage level. If the motor current is such that the batteries are being pulled below the minimum point, the duty cycle will be reduced until the battery voltage recovers to the minimum level. In this way the controller “servos” the duty cycle around the point which maintains the minimum allowed battery voltage.

If the voltage continues to drop below the undervoltage level to a severe undervoltage condition (due to battery drain or external load), the controller continues to behave in a predictable fashion, with its output disabled.

### **Watchdog (external, internal)**

The external watchdog timer guards against a complete failure of the microprocessor, which would incapacitate the internal watchdog timer. This independent system check on the microprocessor meets the EEC's requirement for backup fault detection.

The external watchdog timer safety circuit shuts down the controller (and the microprocessor) if the software fails to generate a periodic external pulse train. This pulse train can only be created if the microprocessor is operating. If not periodically reset, the watchdog timer times out after 15–20 msec and turns off the controller. The external watchdog also directly shuts down the PWM drive to the MOSFETs. It can only be reset by cycling KSI.



The internal watchdog timer must be reset periodically by correct sequential execution of the software. If not reset, the internal timer times out and the microprocessor is “warm booted.” This causes the microprocessor to shut down its outputs—thus shutting down the controller—and attempt to restart.

**Welded contactor check**

The 1254 controller checks for a welded pump contactor at startup. If a welded contactor is detected, the controller inhibits its output until the fault is removed and the keyswitch power is cycled. A welded pump contactor fault is indicated in the programmer’s Diagnostic Menu as well as by the controller’s Status LED.

## APPENDIX B

### MOUNTING DIMENSIONS FOR CURTIS THROTTLES

**Fig. B-1** *Mounting dimensions, Curtis standard 5kΩ, 3-wire potentiometer, p/n 98191.*

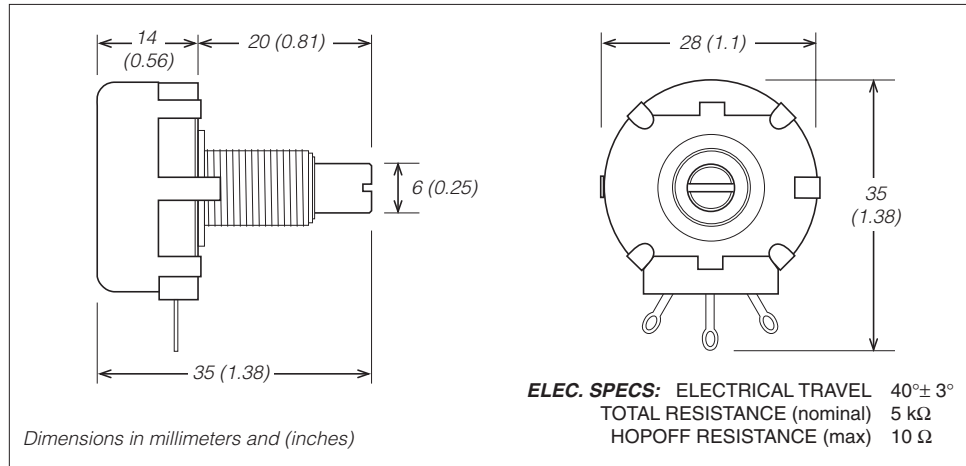

**Fig. B-2** *Mounting dimensions, Curtis potboxes.*

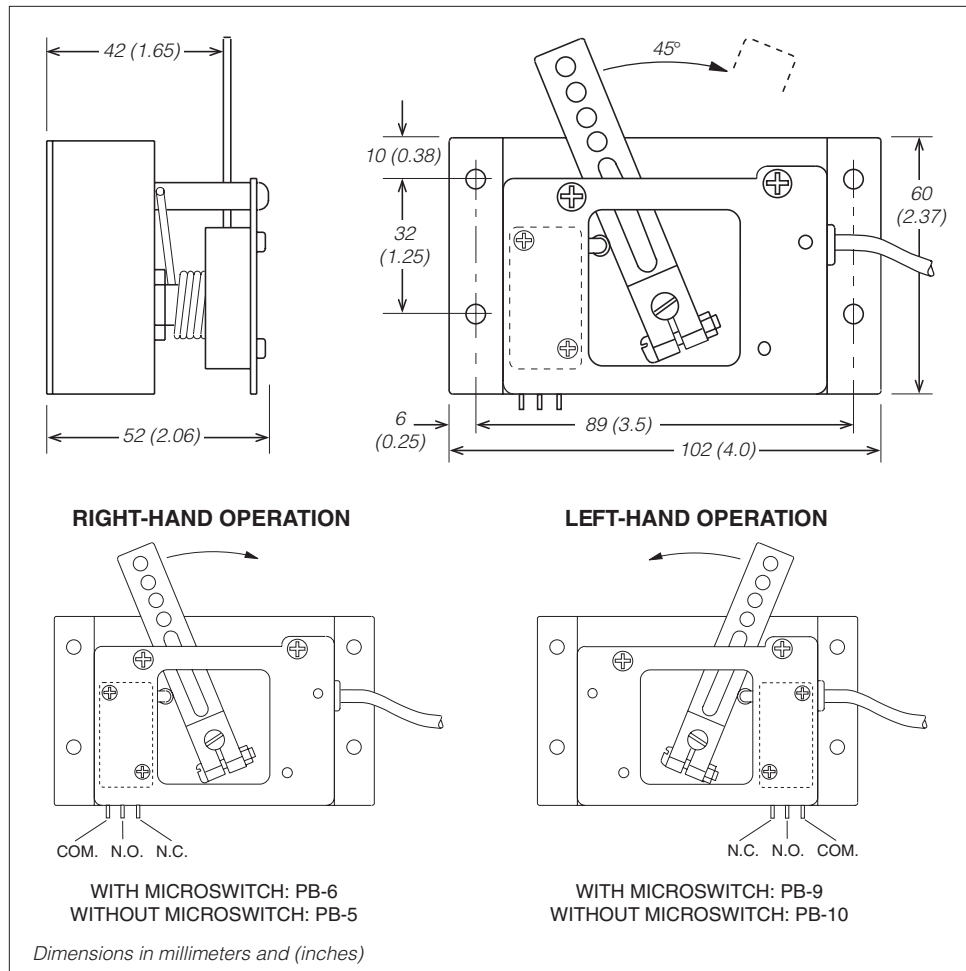

**Fig. B-3** Mounting dimensions, Curtis potentiometer WP-45 CP.

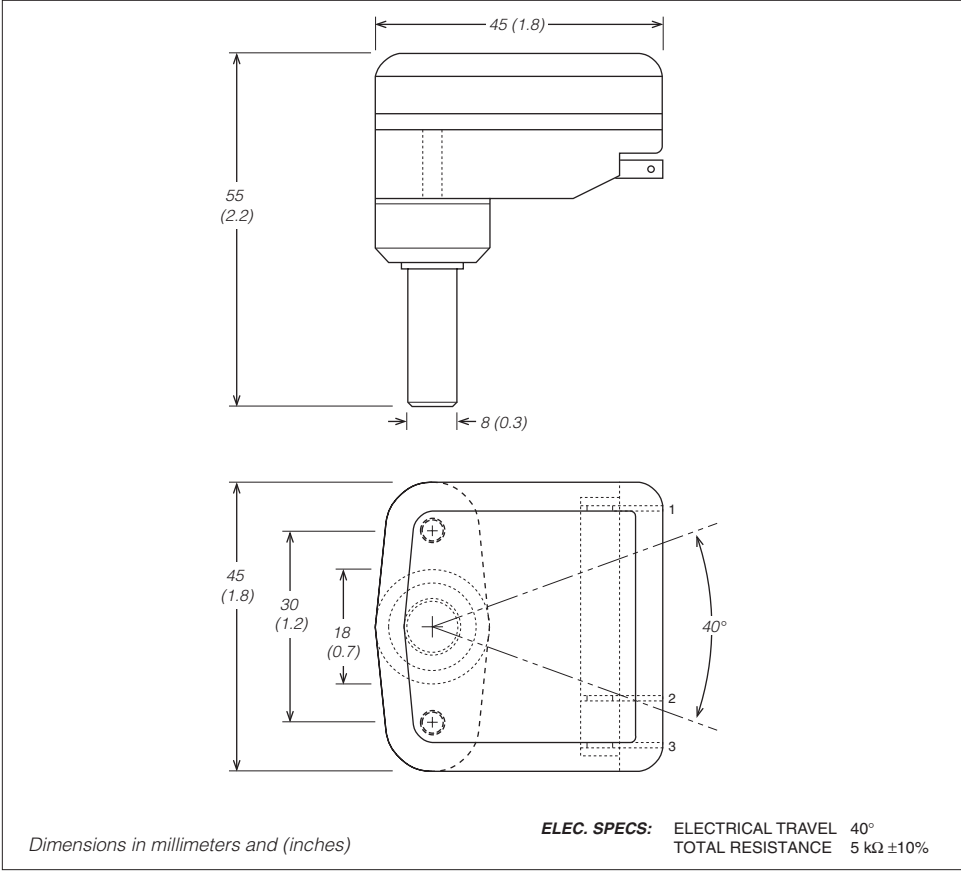

**Fig. B-4** Mounting dimensions, Curtis electronic speed control device (ET series).

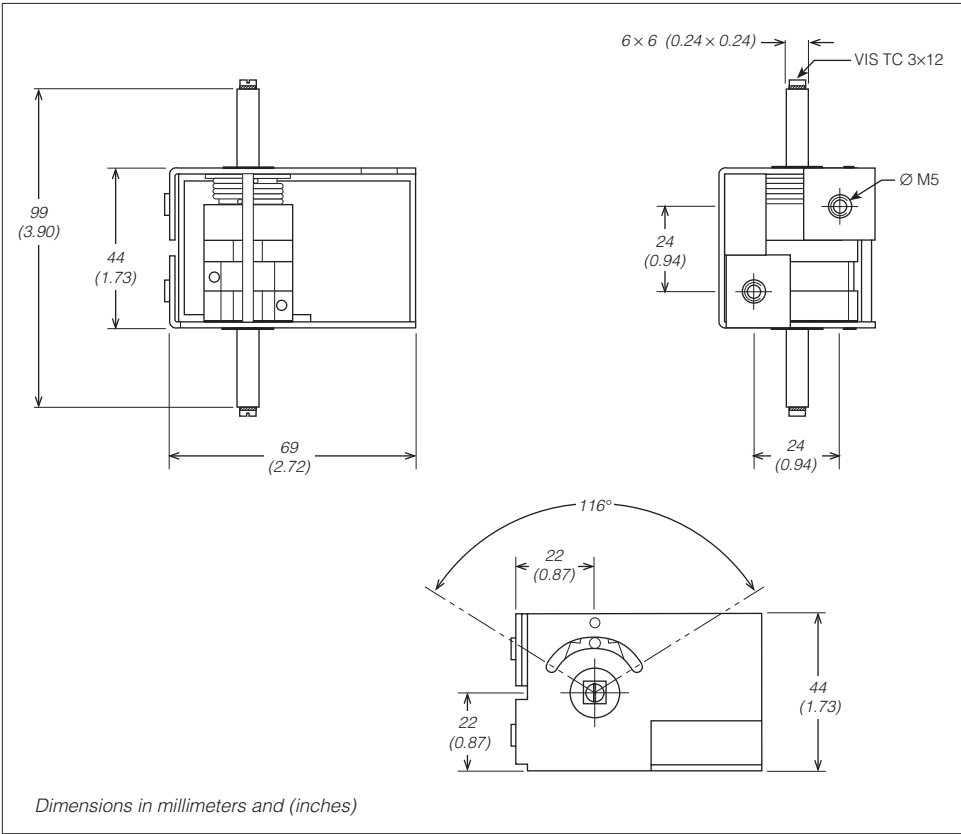

## APPENDIX C

### ELECTROMAGNETIC COMPATIBILITY (EMC)

Electromagnetic compatibility (EMC) encompasses two areas: emissions and immunity. *Emissions* are radio frequency (rf) energy generated by a product. This energy has the potential to interfere with communications systems such as radio, television, cellular phones, dispatching, aircraft, etc. *Immunity* is the ability of a product to operate normally in the presence of rf energy.

EMC is ultimately a system design issue. Part of the EMC performance is designed into or inherent in each component; another part is designed into or inherent in end product characteristics such as shielding, wiring, and layout; and, finally, a portion is a function of the interactions between all these parts. The design techniques presented below can enhance EMC performance in products that use Curtis motor controllers.

#### *Decreasing Emissions*

Motor brush arcing can be a significant source of rf emissions. These emissions may be reduced by installing bypass capacitors across the motor wires and/or between each motor wire and the motor frame. If the latter approach is used, the voltage rating and leakage characteristics of the capacitors must be adequate to meet any safety regulations regarding electrical connections between a battery operated circuit and the chassis. The bypass capacitor should be installed as close to the motor as possible, or even inside it, to provide the best performance. Alternatively a ferrite bead can be installed on the wires, as close as possible to the motor. In some instances, capacitors and ferrite beads may both be appropriate. Another option is to choose a motor with a brush material that will result in less arcing to the commutator. Brushes that have been run in for approximately 100 hours will typically generate lower emissions than new brushes because there is less arcing after they are properly seated.

The motor drive output from Curtis controllers can also make a contribution to rf emissions. This output is a pulse width modulated square wave with rather fast rise and fall times that are rich in harmonics. The impact of these switching waveforms can be minimized by making the wires from the controller to the motor as short as possible. Ferrite beads installed on the drive wires can further reduce these emissions. For applications requiring very low emissions, the solution may involve enclosing the controller, interconnect wires, and motor together in one shielded box. The motor drive harmonics can couple to battery supply leads and throttle circuit wires, so ferrite beads may also be required on these other wires in some applications.

#### *Increasing Immunity*

Immunity to radiated electric fields can be achieved either by reducing the overall circuit sensitivity or by keeping the undesired signals away from this

circuitry. The controller circuitry itself cannot be made less sensitive, since it must accurately detect and process low level signals from the throttle potentiometer. Thus immunity is generally achieved by preventing the external rf energy from coupling into sensitive circuitry. This rf energy can get into the controller circuitry via conducted paths and via radiated paths.

Conducted paths are created by the wires connected to the controller. These wires act as antennas and the amount of rf energy coupled into these wires is generally proportional to their length. The rf voltages and currents induced in each wire are applied to the controller pin to which the wire is connected. Curtis motor controllers include bypass capacitors on the printed circuit board's throttle wires to reduce the impact of this rf energy on the internal circuitry. In some applications, ferrite beads may also be required on the various wires to achieve desired performance levels.

Radiated paths are created when the controller circuitry is immersed in an external field. This coupling can be reduced by enclosing the controller in a metal box. Some Curtis motor controllers are enclosed by a heat sink that also provides shielding around the controller circuitry, while others are unshielded. In some applications, the designer will need to mount the controller within a shielded box on the end product. The box may be constructed of just about any metal, although steel and aluminum are most commonly used.

Most coated plastics do not provide good shielding because the coatings are not true metals, but rather a mixture of small metal particles in a non-conductive binder. These relatively isolated particles may appear to be good based on a dc resistance measurement but do not provide adequate electron mobility to yield good shielding effectiveness. Electroless plating of plastic will yield a true metal and can thus be effective as an rf shield, but it is usually more expensive than the coatings.

A contiguous metal enclosure without any holes or seams, known as a Faraday cage, provides the best shielding for the given material and frequency. When a hole or holes are added, rf currents flowing on the outside surface of the shield must take a longer path to get around the hole than if the surface was contiguous. As more "bending" is required of these currents, more energy is coupled to the inside surface, and thus the shielding effectiveness is reduced. The reduction in shielding is a function of the longest linear dimension of a hole rather than the area. This concept is often applied where ventilation is necessary, in which case many small holes are preferable to a few larger ones.

Applying this same concept to seams or joints between adjacent pieces or segments of a shielded enclosure, it is important to minimize the open length of these seams. Seam length is the distance between points where good ohmic contact is made. This contact can be provided by solder, welds, or pressure contact. If pressure contact is used, attention must be paid to the corrosion characteristics of the shield material and any corrosion-resistant processes applied to the base material. If the ohmic contact itself is not continuous, the shielding effectiveness can be maximized by making the joints between adjacent pieces overlapping rather than abutted.

The shielding effectiveness of an enclosure is further reduced when a wire passes through a hole in the enclosure. RF energy on the wire from an external field is re-radiated into the interior of the enclosure. This coupling mechanism can be reduced by filtering the wire at the point where it passes through the boundary of the shield. Given the safety considerations involved with connecting electrical components to the chassis or frame in battery powered vehicles, such filtering will usually consist of a series inductor (or ferrite bead) rather than a shunt capacitor. If a capacitor is used, it must have a voltage rating and leakage characteristics that will allow the end product to meet applicable safety regulations.

The B+ (and B-, if applicable) wires that supply power to the throttle control panel—such as for the keyswitch—should be bundled with the remaining throttle wires so that all these wires are routed together. If the wires to the control panel are routed separately, a larger loop area is formed. Larger loop areas produce more efficient antennas which will result in decreased immunity performance.

Electrostatic discharge (ESD) immunity is achieved either by providing sufficient distance between conductors and the outside world so that a discharge will not occur, or by providing an intentional path for the discharge current such that the circuit is isolated from the electric and magnetic fields produced by the discharge. In general the guidelines presented above for increasing the radiated immunity will also provide increased ESD immunity.

It is usually easier to prevent the discharge from occurring than to divert the current path. A fundamental technique for ESD prevention is to provide adequately thick insulation between all metal conductors and the outside environment so that the voltage gradient does not exceed the threshold required for a discharge to occur. If the current diversion approach is used, all exposed metal components must be grounded. The shielded enclosure, if properly grounded, can be used to divert the discharge current; it should be noted that the location of holes and seams can have a significant impact on the ESD suppression. If the enclosure is not grounded, the path of the discharge current becomes more complex and less predictable, especially if holes and seams are involved. Some experimentation may be required to optimize the selection and placement of holes, wires, and grounding paths. Careful attention must be paid to the control panel design so that it can tolerate a static discharge.

## APPENDIX D

### SPEED CONDITIONING DIAGRAMS

The following diagrams illustrate the control sequence the 1254 controller uses in responding to multiple speed requests—from more than one throttle, from more than one speed select switch, or from a combination of throttles and speed select switches.

The second diagram differs from the first only in that Throttle 1 and speed select switches SS1–SS3 have been integrated into a multifunction control handle.

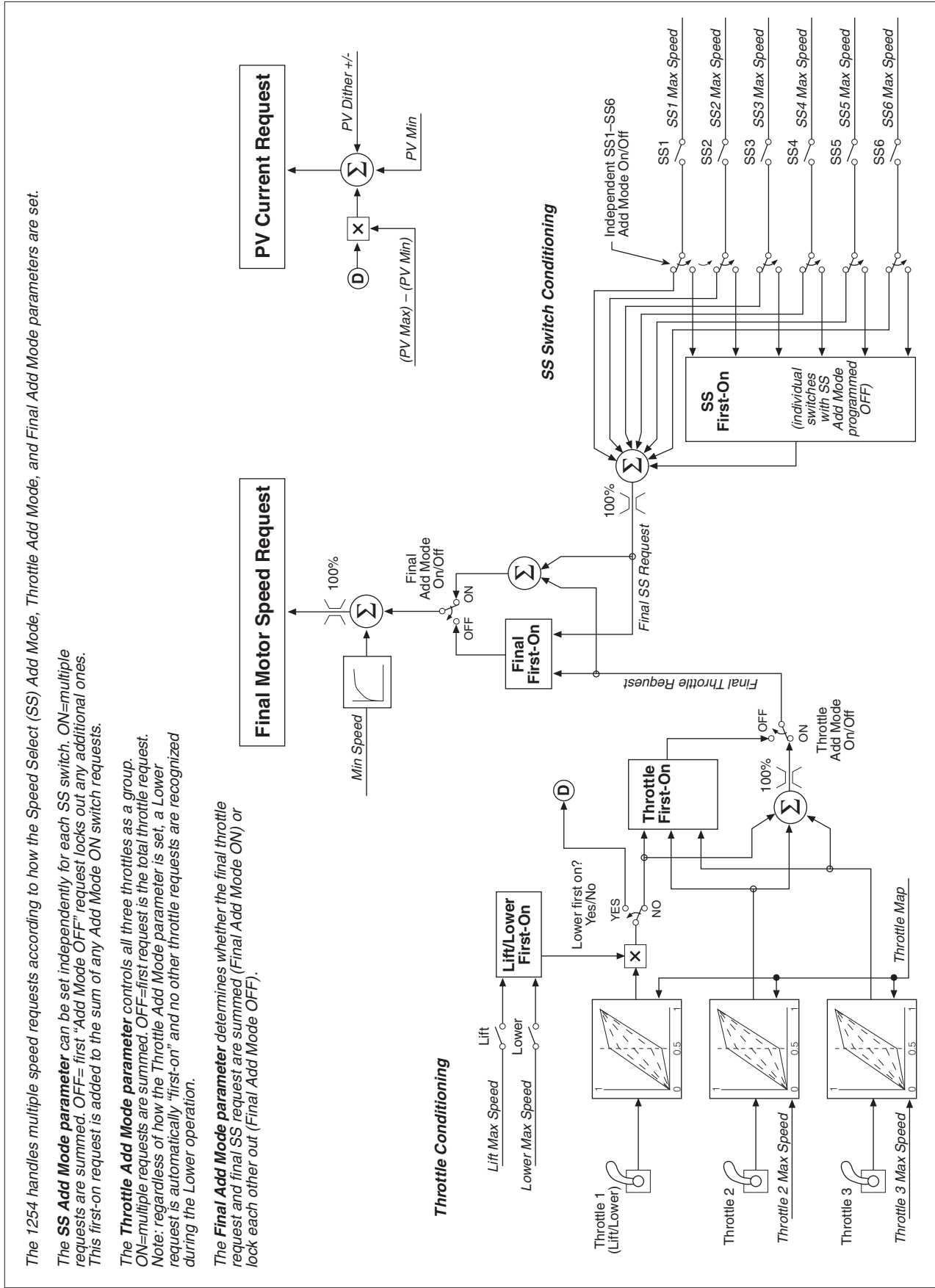

Fig. D-1 Speed conditioning diagram, basic configuration.



The **Multifunction parameter** allows Lift and Lower to be combined with up to three additional operations (controlled by Speed Selects SS1, SS2, SS3) in a single multifunction control handle, governed by Throttle 1. When Multifunction is programmed ON, Throttle 1 scales the maximum speeds of all the functions included in the handle. All the functions in the handle are automatically "first-on," regardless of how they were individually programmed.

When Multifunction is programmed OFF, Throttle 1 no longer scales the SS1-SS3 operations, and their individually set SS Add Mode parameters are in effect (see Figure D-1).

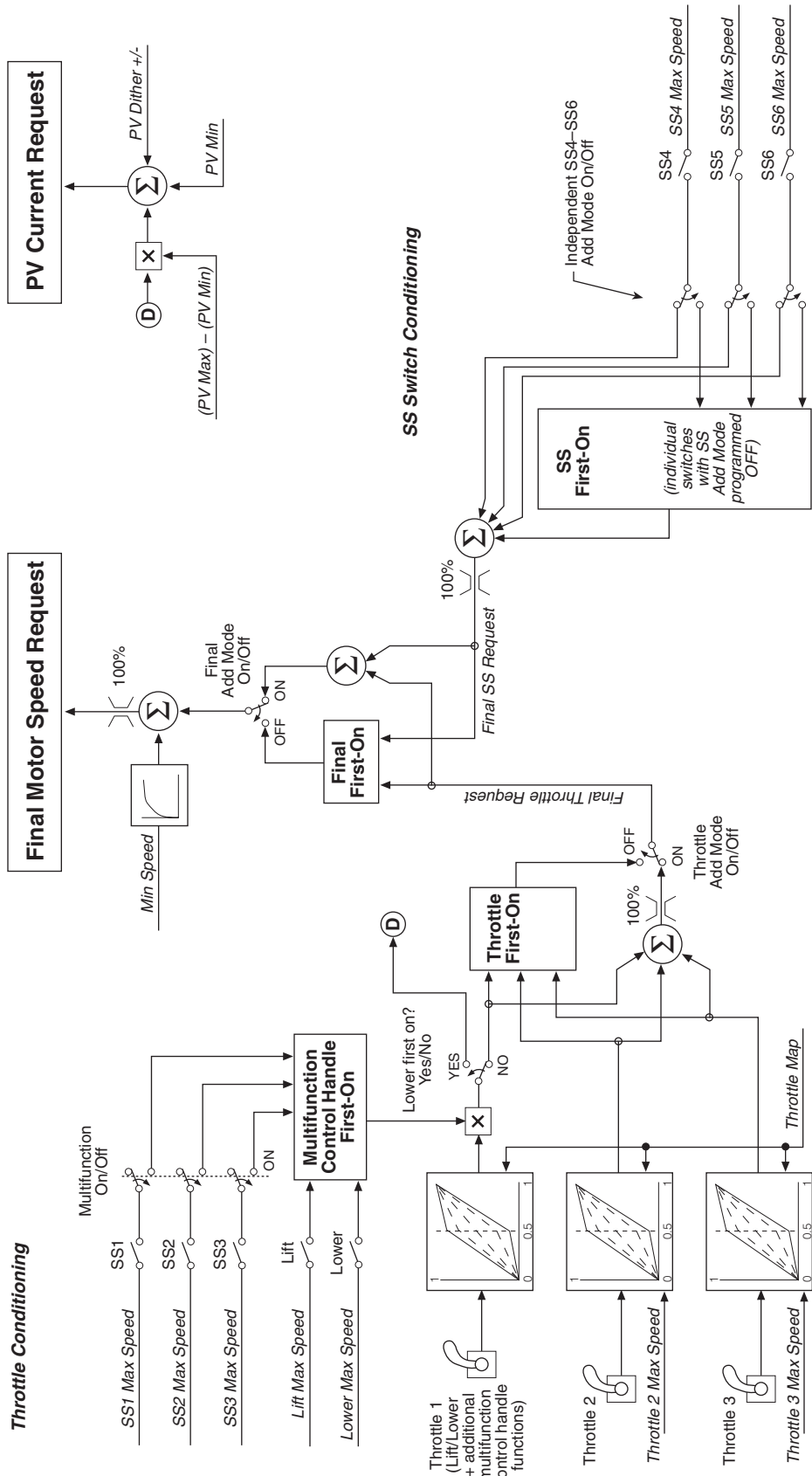

Fig. D-2 Speed conditioning diagram, with multifunction control handle.

## APPENDIX E

### CURTIS WEEE / RoHS STATEMENT, MARCH 2009

#### WEEE

The Directive 2002/96/EC on Waste Electrical and Electronic Equipment (WEEE) was adopted by the European Council and Parliament and the Council of the European Union on January 27, 2003. The aim of the directive was to improve the collection and recycling of WEEE throughout the EU, and to reduce the level of non-recycled waste. The directive was implemented into law by many EU member states during 2005 and 2006. This document provides a general description of Curtis's approach to meeting the requirements of the WEEE legislation.

Note that the directive gave some flexibility to the member states in implementing their individual WEEE regulations, leading to the definition of varying implementation requirements by country. These requirements may involve considerations beyond those reflected in this document. This statement is not intended and shall not be interpreted or construed to be legal advice or to be legally binding on Curtis or any third party.

#### *Commitment*

Curtis is committed to a safe and healthy environment and has been working diligently to ensure its compliance with WEEE legislation. Curtis will comply with WEEE legislation by:

- Designing its equipment with consideration to future dismantling, recovery and recycling requirements;
- Marking its products that fall within the scope of the directive with the required symbol and informing users of their obligation;
- To separate WEEE from general waste and dispose of it through the provided recycling systems;
- Reporting information as required by each member state;
- Facilitating the collection, recycling and disposal of WEEE from private households and other than private households (businesses) as defined by the applicable member state regulation;
- Providing information to treatment centres according to the requirements defined in the local regulation.

#### *WEEE symbol on Curtis products*



The requirement to mark equipment with the WEEE symbol (the crossed-out wheeled bin) went into effect as of August 13, 2005. As of this date, Curtis Instruments began the process of marking all products that fall within scope of this directive with the WEEE symbol, as shown opposite.

#### *Obligations for buyers of electrical and electronic equipment*

As of 13 August 2005, in each EU member state where the WEEE directive has been implemented, disposal of EEE waste other than in accordance with the scheme

is prohibited. Generally, the schemes require collection and recycling of a broad range of EEE products. Certain Curtis products fall within the scope of the directive and the implemented member state regulations. Affected Curtis products that have reached end-of-life must not be disposed as general waste, but instead, put into the collection and recycling system provided in the relevant jurisdiction.

## **RoHS**

For several years now, Curtis has been implementing a rigorous program with the aim of achieving full compliance with the Restrictions on the use of Hazardous Substances (RoHS) Directive, 2002/95/EC.

Curtis has taken all available steps to eliminate the use of the six restricted hazardous substances listed in the directive wherever possible. As a result of the Curtis RoHS program, many of our instrumentation product lines are now fully RoHS compliant.

However, Curtis's electronic motor speed controller products are safety-critical devices, switching very large currents and designed for use in extreme environmental conditions. For these product lines, we have successfully eliminated five out of the six restricted hazardous substances. The single remaining issue preventing full RoHS compliance is the unsuitability of the lead-free solders available to date, due to the well-documented issues such as tin whiskers, and premature failure (compared with leaded solder) due to shock, vibration, and thermal cycling.

Curtis is closely monitoring all RoHS developments globally, and in particular is following the automotive industry's attempts to introduce lead-free solder as a result of the End of Life Vehicle (ELV) Directive, 2003/53/EC. To date, the automotive industry has rejected all lead-free solder pastes due to a significant reduction in reliability compared to leaded soldering.

Curtis firmly believes that the operating environments, safety requirements, and reliability levels required of automotive electronics are directly analogous to that of our speed controller products. As such, Curtis will not be switching to a lead-free solder process until lead-free solder pastes and techniques are available that meet the requirements of the RoHS study groups and ELV Automotive Industry bodies. That is, when all known issues, including that of tin whiskers, are satisfactorily resolved.

At this moment in time, all Curtis motor speed controllers used on industrial vehicle applications are also regarded as exempt under EEE category 9 of the RoHS directive 2002/95/EC. This means there is no requirement at this time for Curtis control systems used on such equipment to comply with the directive. Curtis will work closely with all key customers to ensure that whenever possible, we are in a position to continue the supply of products should these exemptions expire.

## APPENDIX F

### SPECIFICATIONS

**Table F-1 SPECIFICATIONS: 1254 CONTROLLER**

Nominal input voltage	24–36V, 36–48V, and 36–84 V
PWM operating frequency	16 kHz
Electrical isolation to heatsink	500 V ac (minimum)
KSI input voltage (minimum)	14 V
KSI input current (no contactors engaged)	100 mA without programmer; 200 mA with programmer
Logic input voltage	>7.5 V High; <1 V Low
Logic input current	10 mA
Operating ambient temperature range	-40°C to 50°C (-40°F to 122°F)
Storage ambient temperature range	-25°C to 85°C (-13°F to 185°F)
Heatsink overtemperature cutback	linear cutback starts at 85°C (185°F); complete cutoff at 95°C (203°F)
Heatsink undertemperature cutback	50% armature current at -25°C (-13°F); complete cutoff at -40°C (-40°F)
Package environmental rating	IP64 / IP67
Weight	4.2 kg (9.2 lb)
Dimensions (L×W×H)	229 × 178 × 81 mm (9.0" × 7.0" × 3.2")

MODEL NUMBER	NOMINAL BATTERY VOLTAGE (volts)	ARMATURE CURRENT LIMIT (amps)	ARMATURE 2 MIN RATING * (amps)	ARMATURE 1 HOUR RATING * (amps)	UNDERVOLTAGE / OVERVOLTAGE PROTECTION			
					<i>The 1254 performs a linear cutback of armature current, starting at the threshold point (100%) and ending at the total cutoff point (0%). These points are determined by the setting of the battery voltage parameter, as follows.</i>			
					Battery Voltage Setting	Nominal Battery Voltage	UNDERVOLTAGE	
							Threshold	Total Cutoff
1254-44XX	24–36	400	400	160	2	24V	16V	14V
1254-45XX	24–36	500	500	180	3	36V	24V	22V
1254-46XX	24–36	600	600	200	4	48V	32V	29V
1254-47XX	24–36	700	700 †	200	5	60V	39V	37V
1254-54XX	36–48	400	400	150	6	72V	49V	44V
1254-55XX	36–48	500	500	170	7	84V	57V	52V
1254-56XX	36–48	600	600	190				
1254-64XX	36–84	400	400	140				
1254-65XX	36–84	500	500	160				
1254-66XX	36–84	600	600 †	160				
					Battery Voltage Setting	Nominal Battery Voltage	OVERVOLTAGE	
							Threshold	Total Cutoff
* controller mounted to 12"×12"× $\frac{1}{8}$ " aluminum plate, with continuous 3 mph airflow perpendicular to back of plate; 25°C ambient temperature; 15A field for 1-hour ratings, 40A field for 2-min. ratings  † 1-minute rating					2	24V	28V	31V
					3	36V	43V	46V
					4	48V	55V	61V
					5	60V	70V	76V
					6	72V	85V	92V
					7	84V	97V	105V