

GE 303Y1, 352/503Y2

This sheet is provided to aid in the installation of your remanufactured General Electric controller. Upon installation, you may encounter problems that may, or may not, be due to a faulty controller. The following steps must be taken to help diagnose a possible cart fault or faulty controller. An analog or digital volt ohm meter (VOM) will be needed to perform these checks



WARRANTY WILL BE VOID **If These Steps are Not Performed Before Installing The Control**

➔ STEPS TO PERFORM **BEFORE** CONTROL INSTALLATION ➔

CHECK MOTOR WINDINGS:

- Set your VOM to RESISTANCE (Ω).
- With your motor disconnected, measure A1 to A2. This must measure BETWEEN $.3\Omega$ and 1Ω .
- With your motor disconnected, measure F1 to F2. This must measure BETWEEN 1Ω and 2Ω .
- With your motor disconnected, measure A1 to F1. This must measure OPEN.
- With your motor disconnected, measure F1 to motor case. This must measure greater than $5M\Omega$.

CHECK MAIN SOLENOID:

- Disconnect all wires from the main solenoid.
- Set your VOM to RESISTANCE (Ω).
- Measure the solenoid coil. This must measure NO LESS than 180Ω .
- Connect VOM leads to the main solenoid lugs.
- Attach jumpers from main battery positive and negative to the coil (small terminals).
- Meter must jump from infinity to LESS THAN $.3\Omega$.
- Remove jumpers and reconnect solenoid wiring from the harness. (If suppression diode is present, the non-banded side must go to the red/black wire – pin 11 from the controller.)

CHECK THE CART WIRE HARNESS:

- Check the connectors on the wire harness for corrosion, loose, broken, burnt or missing pins.
- Repair or replace pins as necessary.

**IF ANY OF THE ABOVE ITEMS ARE NOT WITHIN THE SPECIFIED RANGES THE CONTROLLER WILL FAIL.
THESE ITEMS MUST BE CORRECTED BEFORE THE CONTROLLER IS INSTALLED OR WARRANTY WILL BE VOID.**

It is recommended to replace your solenoid at the time of controller replacement. FSIP now stocks popular replacement White Rodgers solenoids for your convenience.

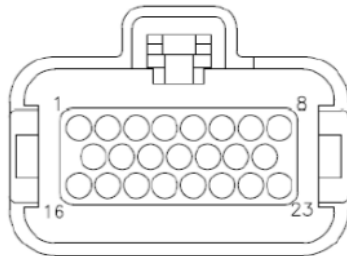
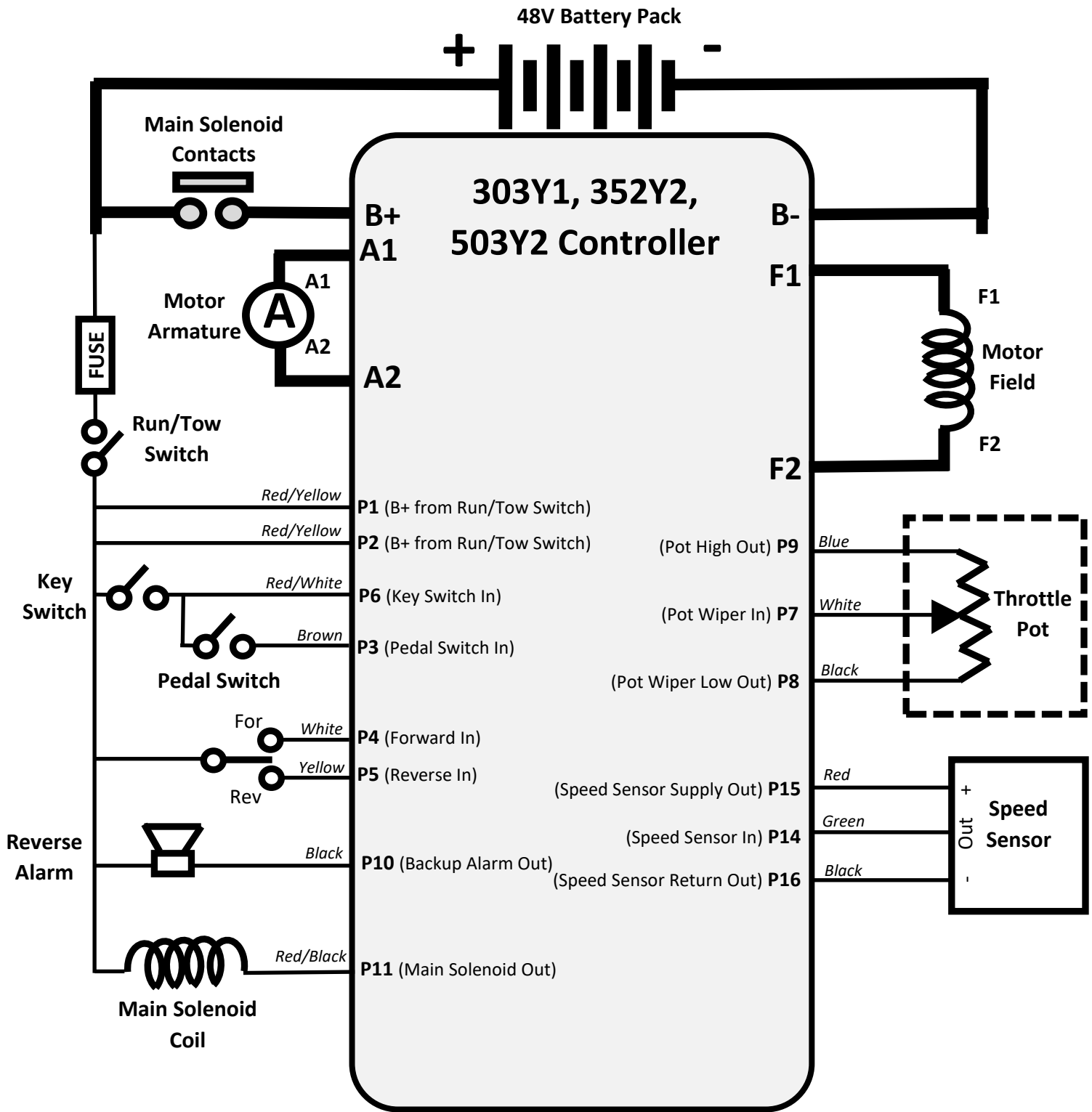

Diagram shows the back (wire) side of Connector

Yamaha G19 Troubleshooting Sequence

FOR SAFETY, ALWAYS LIFT THE DRIVE WHEELS OFF THE GROUND WHEN TROUBLESHOOTING!

ALL TESTS ARE CONDUCTED WITH RUN-TOW/MAINTENANCE SWITCH IN THE RUN POSITION AND WITH A GOOD BATTERY PACK VOLTAGE MEASUREMENT. ALSO, THE CONNECTOR MUST BE ATTACHED TO THE CONTROLLER WHEN MAKING THESE CHECKS. YOU WILL NEED TO 'BACK PROBE' THE PINS FROM THE WIRE SIDE OF THE CONNECTOR. USE A PAPERCLIP IF NECESSARY.

Attach voltmeter negative (-) lead to main battery – for the following tests

Use the following sequence when checking individual pins (don't skip steps). **If you find a fault, do not move on to the next step until the fault is corrected:**

- Measure the voltage at the main battery positive post (let's call it Pack Voltage)
- Pin 1** Must be equal to Pack Voltage
 - *If not Pack Voltage, check wiring and Fuse for open condition*
- Pin 2** Must be equal to Pack Voltage
 - *If not Pack Voltage, check wiring and Fuse for open condition*
- Pin 6** **With Key Switch Off**, must equal 0 volts
 - *If not 0 volts, check wiring and Key Switch for a shorted condition*
- Pin 6** **With Key Switch On**, must equal Pack Voltage
 - *If not Pack Voltage, check wiring and Key Switch for an open condition*
- Pin 3** **With Key Switch On and Pedal Up**, must equal 0 volts
 - *If not 0 volts, check wiring and Pedal Switch for a shorted condition*
- Pin 3** **With Key Switch On and Pedal Down**, must equal Pack Voltage
 - *If not Pack Voltage, check wiring and Pedal Switch for an open condition*
- Pin 4** **With F/R Switch in Reverse**, must equal 0 volts
 - *If not 0 volts, check wiring and F/R Switch for a shorted condition*
- Pin 4** **With F/R Switch in Forward**, must equal Pack Voltage
 - *If not Pack Voltage, check wiring and F/R Switch for an open condition*
- Pin 5** **With F/R Switch in Forward**, must equal 0 volts
 - *If not 0 volts, check wiring and F/R Switch for a shorted condition*
- Pin 5** **With F/R Switch in Reverse**, must equal Pack Voltage
 - *If not Pack Voltage, check wiring and F/R Switch for an open condition*
- Pin 10** **With Direction Switch in Neutral**, must equal Pack Voltage
 - *If not Pack Voltage, check wiring and make sure beeper is present and connected*
- Pin 10** **With Direction Switch in Reverse**, must equal approximately 0 volts (and beeper sounds)
 - *If not approximately 0 volts, check connector and wire terminal for being burnt/corroded. If terminal is clean, controller may be defective*
- Pin 8** Must equal 0 volts
 - *If not 0 volts, check connector and wire terminal for being burnt/corroded. If terminal is clean, controller may be defective*
- Pin 9** Must equal approximately 3.5 volts
 - *If not approximately 3.5 volts, check connector and wire terminal for being burnt/corroded. If terminal is clean, controller may be defective*

Continued on next page ...

- Pin 7 *With Pedal Up***, must be less than approximately .5 volts
 - *If not less than approximately .5 volts, check wiring and throttle pot for shorted condition*
- Pin 7 *With Pedal Fully Down***, must equal approximately 3.5 volts
 - *If not approximately 3.5 volts, check wiring and throttle pot for open condition*
- Pin 15** Must equal approximately 11.5 volts
 - *If not approximately 11.5 volts, remove speed sensor to see if voltage recovers to 11.5 volts. If it does return to 11.5 volts, replace speed sensor, if it does not return to 11.5 volts, check wiring*
- Pin 16** Must equal approximately 0 volts
 - *If not approximately 0 volts, check terminal for being burnt/corroded. If terminal is clean, controller may be defective.*
- Pin 14 *While slowly turning the drive wheel***, must toggle between 0 volts and approximately 4.5 volts
 - *If not toggling, check wiring and if necessary replace Speed Sensor and magnet*
- Pin 11 *With Pedal Up***, must equal approximately pack voltage
 - *If not approximately pack voltage, check solenoid coil and wiring for an open condition*
- Pin 11 *With Pedal Down***, must equal approximately 0 volts
 - *If not approximately 0 volts, check terminal for being burnt/corroded. If terminal is clean, controller may be defective.*

Helpful Hints

- DO NOT UNDER ESTIMATE THE IMPORTANCE OF MOTOR RESISTANCE CHECKS AND MAIN SOLENOID CHECKS. MANY CART ISSUES ARE CAUSED BY BURNT/DAMAGED BRUSHES THAT WILL BE FOUND AS PART OF THE ARMATURE RESISTANCE CHECK. ALSO A SHORTED ARMATURE AND FIELD WITHIN THE MOTOR WILL DAMAGE THIS CONTROLLER.**

Flight Systems Industrial Products also offers the following Technical Support options ...



Troubleshooting Manuals / Codes
www.fsip.biz/TroubleshootingManuals.html



Live Tech Support Chat
www.fsip.biz



Technical Support Forum
fsip.websitetoolbox.com



Frequently Asked Questions
www.fsip.biz/FAQ.html

Phone Support
 1-800-333-1194 (Option 4)

**PRE-INSTALLATION
 INSTRUCTIONS MUST BE
 FOLLOWED OR WARRANTY
 WILL BE VOID**

**IMPORTANT!
 YAMAHA G19
 TROUBLESHOOTING INFORMATION
 INCLUDED IN THIS PACKET**