

SEPARATELY EXCITED MOTOR SPEED CONTROLLER

MODEL 1274

CURTIS



DESCRIPTION

Curtis PMC Model 1274 Separately Excited Motor Speed Controllers integrate all of the functions necessary to provide fully featured electric light on-road vehicles or similar vehicles requiring speed limiting and multiple profile capabilities.

Application

The Curtis PMC Model 1274 is ideally suited for Light On-Road Vehicles such as neighborhood electric vehicles, two-passenger cars and similar modes of transportation.

Features

Rugged, Powerful and Flexible

- Provides the rugged reliability of SepEx[®] regenerative traction motor control with the safety features required for Light-On-Road vehicle operation.
- The rugged IP64 housing and packaging can withstand the extreme environments associated with on road use.
- Easy integration with many three-wire resistive (5K Ω potentiometer) or 0 - 5 Volt electronic throttles (available from Curtis) allows for flexibility in OEM vehicle design.
- In high volume OEM applications, custom versions of model 1274 can be made available for a speed sensorless operation in which the controller limits top vehicle speed based on a speed estimating algorithm.

Fully Programmable

- FLASH memory incorporated in model 1274 design allows for quick and easy updates by the OEM.
- Fully compatible with THE 1311 Curtis handheld or P.C. based programmers for testing, diagnostics and parameter adjustments.
- Acceleration and deceleration profiles can be defined for optimal vehicle response in multiple modes.
- Vehicle top speed is programmable.
- Field maps, battery current limits and armature current limits are programmable to assure optimal motor performance.

Safety Features

- The Model 1274 includes the safety features required in the operation of a light on road vehicle including:
 - High Pedal Disable
 - Brake/Drive Interlock
- Self monitoring functions identify, respond to and report faults via the Fault Status LED, fault drive output and serial port.
- Self protecting functions include linear over-temperature cutback, over-voltage and under-voltage protection.

Features...continued

Meets U.S. and International Regulations

- The Curtis Model 1274 Controller is designed to meet:
 - EN 50081-2:1993 for EMI emissions
 - EN 50082-2:1995 for EMC immunity
 - EN 1175-1:1998
 - EN 12895:2000
 - EN ISO14982:1998
 - UL 583 Recognized component
 - UL 94V0 for flammability resistance (enclosure only)
 - IP64 rated for dust and splash protection.

Model Chart

Model Number	Voltage Rating (volts)	Current Rating (amps) 2 minutes	Control Wiring (volts) †	Speed Sensor Required*
1274-5401	48	400	48	Yes
1274-5402	48	400	12	Yes
1274-7401	72	400	72	Yes
1274-7402	72	400	12	Yes

*Speed sensor is required for closed loop speed control

† DC-DC Converter required for 12 volt output. Curtis Model 1400E is preferable.

Connector

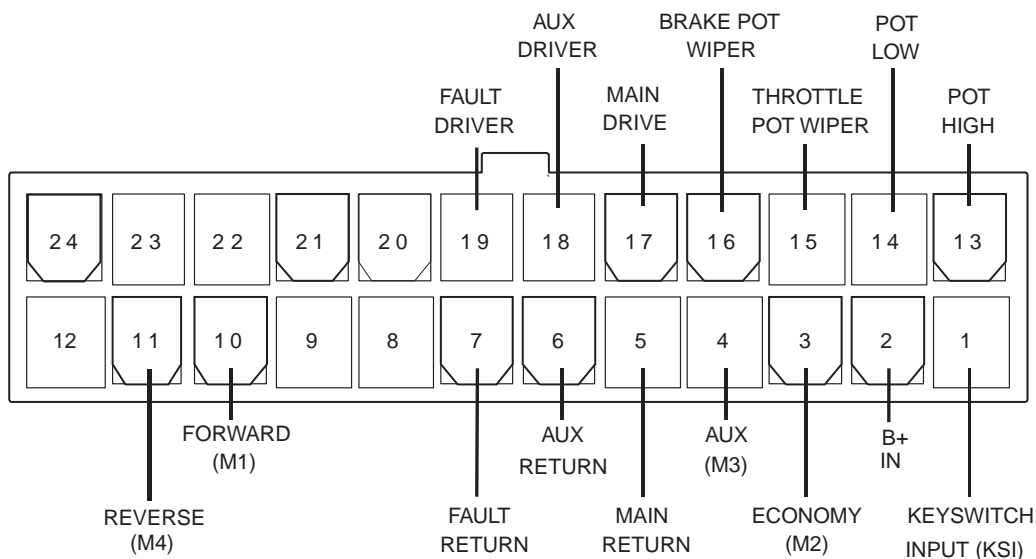

1274 Standard Control Wiring Diagram

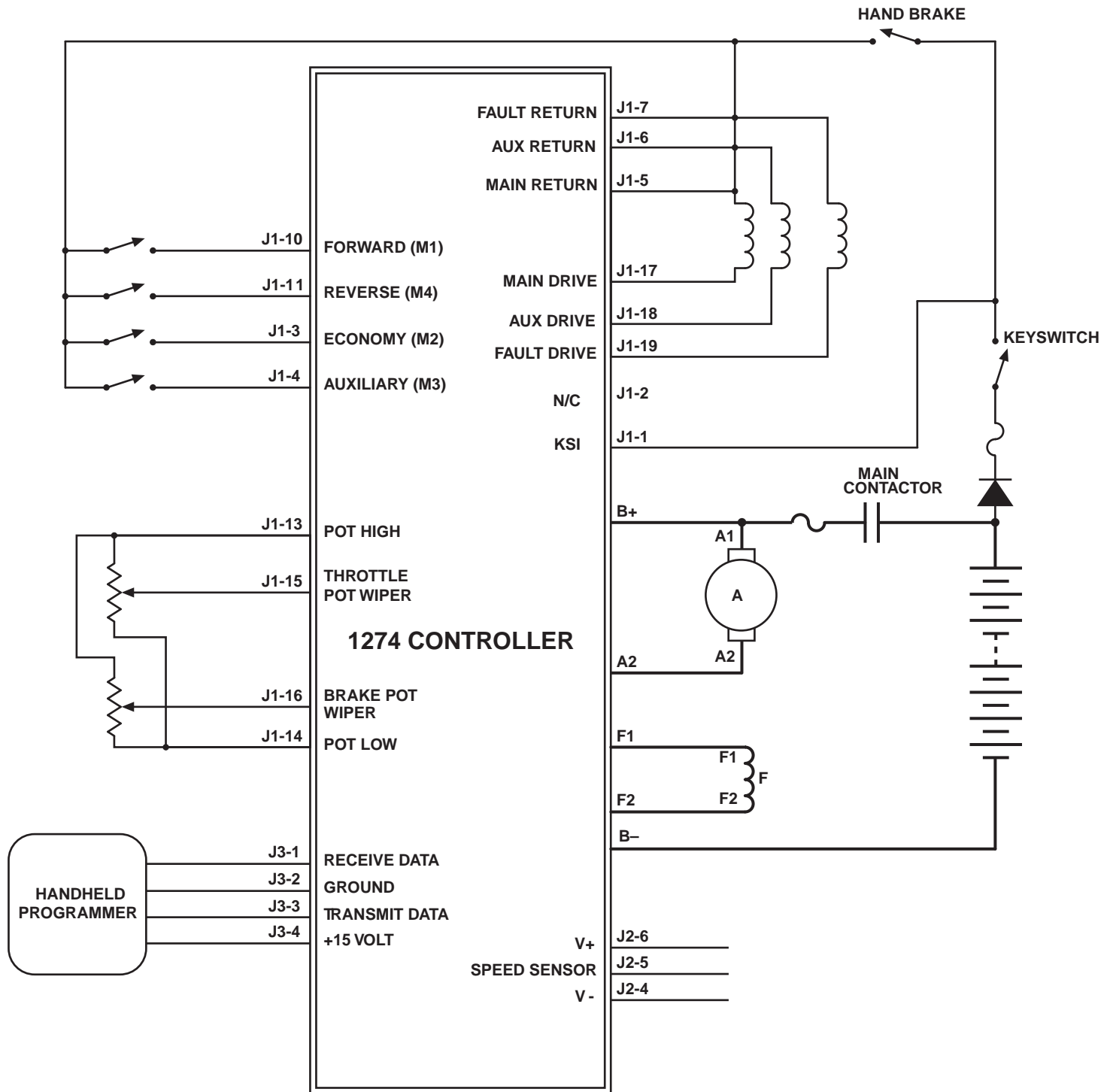

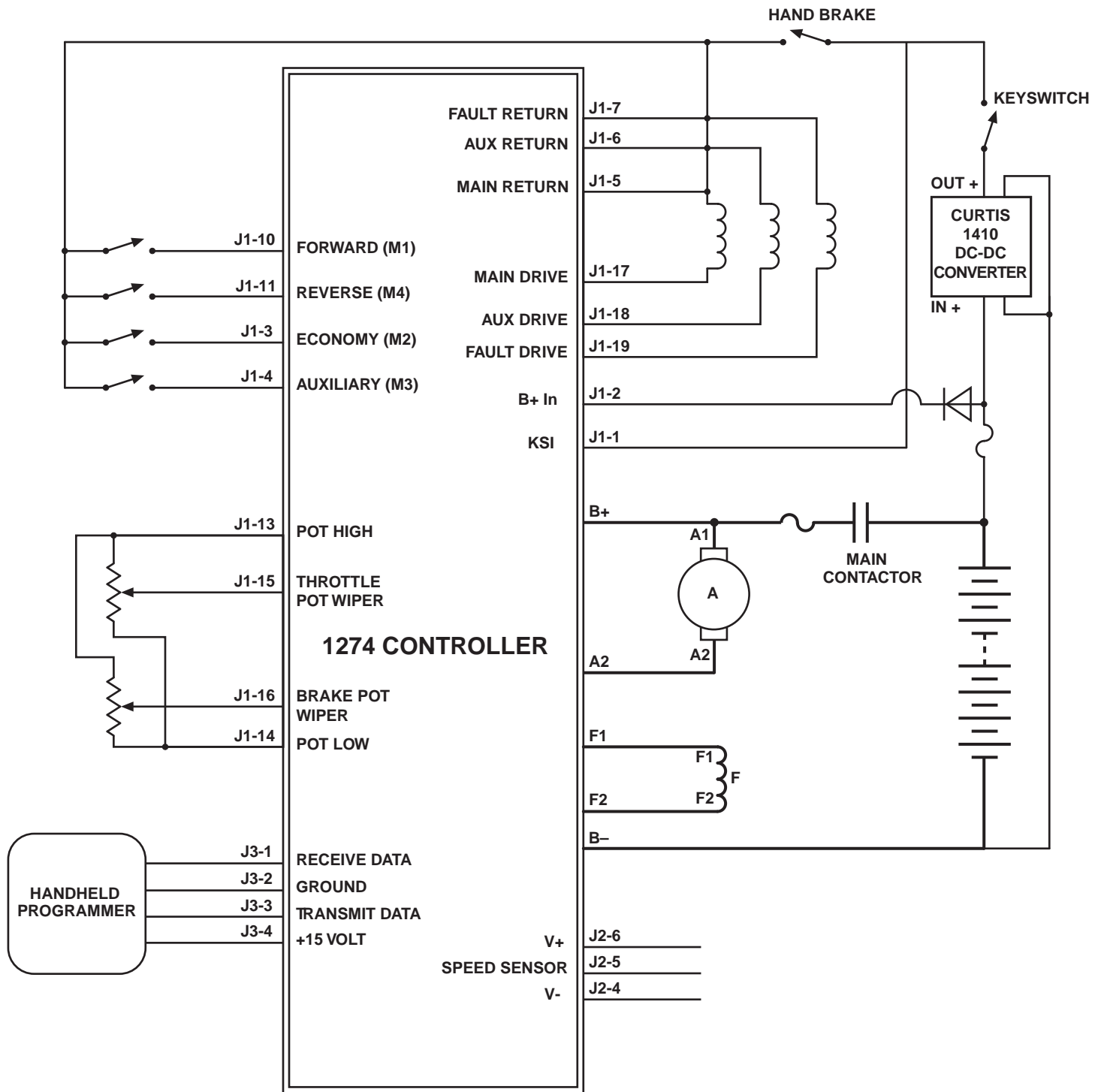

Dimensions: mm (inches)

